

# 95T ELEVATION SERIES TREADMILLS

Service Manual  
M051-00K65-A003 11/16/09



*LifeFitness*  
WHAT WE LIVE FOR

# Table of Contents

---

<b>Table of Contents</b> .....	<b>2</b>
<b>Introduction</b> .....	<b>5</b>
Using This Manual .....	6
Contact Information .....	7
System Level Troubleshooting .....	9
<b>Preparation</b> .....	<b>10</b>
Required Service Tools .....	11
Specialty Tools .....	12
<b>Maintenance</b> .....	<b>13</b>
Preventive Maintenance Schedule .....	14
<b>Modules</b> .....	<b>19</b>
Drive Motor (DS) .....	20
System Component .....	20
Problem Symptoms Table .....	21
How To's .....	22
Base Frame Electronics (BE) .....	24
Theory of Operation .....	24
System Components .....	28
Problem Symptom Table .....	29
Troubleshooting Flow Diagrams .....	31
How To's .....	34
Electrical Wiring Diagrams .....	38
Lift System (LS) .....	41
Theory of Operation .....	41
System Components .....	42
Problem Symptom Table .....	44
How To's .....	46
Console & Activity Zone (CA) .....	51

## Table of Contents

---

Theory of Operation .....	51
System Components .....	55
Problem Symptom Table .....	58
Troubleshooting Flow Diagrams .....	61
How To's .....	72
Electrical Wiring Diagrams .....	75
Heart Rate System (HR) .....	77
Lifepulse® Theory of Operation .....	77
System Components .....	79
Problem Symptom Table .....	80
How To's .....	81
Stride (Walking) System (SS) .....	83
Theory of Operation .....	83
System Components .....	84
Problem Symptom Table .....	85
How To's .....	88
Lower Frame (LF) .....	95
System Components .....	95
Problem Symptom Table .....	96
How To's .....	97
Upper Frame (UF) .....	102
System Components .....	102
Problem Symptom Table .....	103
How To's .....	104
<b>Appendix .....</b>	<b>109</b>
Engage / Inspire Console Diagnostic .....	110
Overview .....	110
System Options - Block Diagram Overview .....	111
System Options - Main Menu .....	112
System Test Menu 1 .....	113
System Communication Check .....	114
Motor Modules (TR Only) .....	115
System Diagnostics Check (Non – TR only) .....	116
Key Pad Test .....	117
Heart Rate Test .....	118

## Table of Contents

---

iPod® Test .....	119
Test Engineering .....	120
System Test Menu 2 .....	121
Stride Sensor Test (TR only) .....	122
External Serial EE Test .....	123
CSAFE Network Test or Status .....	124
CSAFE Loopback Test .....	125
Information Menu .....	126
Information Statistics .....	127
Software Versions .....	129
Main Motor Information (TR Only) .....	130
Lift Motor Information (TR Only) .....	138
Belt / Deck Information (TR Only) .....	139
Date and Time Information .....	140
System Errors .....	141
Maintenance Information .....	142
Usage Log Report .....	143
Channel Usage Log .....	144
Configuration Menu .....	145
Manager Configuration 1 .....	146
Manager Configuration 2 .....	147
Manufacturer's Configuration .....	148
Video / FM Radio Configuration Menu .....	151
Video Setup Screen .....	152
Channel Name / Sort Setup Screen .....	153
Secure Channel Setup Screen .....	154
Promo Channel Setup Screen .....	155
FM Radio Setup Screen .....	156
Custom Workouts Screen .....	157
Export / Import Settings .....	158
Create Your Own Screen .....	159
Network Configuration .....	160
Clock Setup (Date and Time Information) .....	161
Maintenance .....	162
Error / Info Messages .....	163

# ***Introduction***

The background is a solid teal color with several curved, overlapping bands of a lighter shade of teal. These bands create a sense of movement and depth, starting from the right side and curving towards the left. The overall effect is modern and clean.

This service manual provides safe and efficient test and service procedures for the 95T Elevation Series treadmills. The service manual is arranged in the following sections:

**Introduction**

This section provides the usage guidelines, contact information, technical specifications and glossary of terms used in this manual.

**Preparation**

This section provides the list of service tools required to perform various service operations described in this manual.

**Maintenance**

This section describes a suggested preventive maintenance schedule for the equipment.

**Theory of Operation**

This section describes the working principle of a treadmill, described for various components such as mechanical, electrical and software.

**Electrical Wiring Diagrams**

This section contains all the electrical wiring diagrams for various components of the 95T Elevation series treadmill. A basic block level diagram is explained, followed by detailed working of each component.

**Modules**

This service manual has been organized by several operational modules of treadmill. Each module contains its own troubleshooting guides (symptom tables and flow diagrams), electrical wiring diagrams (if required) and How To's.

**Index**

To find information when a service problem occurs:

- Use the top-level troubleshooting guideline to determine the module.
- Check the corresponding module section's troubleshooting to zoom in to the root cause.
- Follow the service procedures described using the How To's section for the module.

Refer to Electrical Wiring Diagrams section for various block diagrams and connector locations. Unless otherwise specified, standard tools listed in the Preparation section should be used.

To speed Life Fitness Customer Support Service's response, please provide the following information to the customer support technician:

- Model number
- Serial number (a 3-letter, 6-number sequence)
- Symptom of problem

**Front View**

Location of model and serial numbers

**Rear View**

Location of model and serial numbers

**Corporate Headquarters**

5100 River Road, Schiller Park, Illinois 60176 U.S.A.

**Toll-Free:** 800.735.3867 (within U.S.A., Canada)

**Tel:** (847) 288 3300

**Fax:** (847) 288 3703

**Global Website:** [www.lifefitness.com](http://www.lifefitness.com)

**International Offices****AMERICA'S****NORTH AMERICA****Life Fitness Inc.**

5100 N River Road, Schiller Park, IL 60176 U.S.A.

**Tel:** (847) 288 3300

**Fax:** (847) 288 3703

**Service Email:** [internationalservicesupport@lifefitness.com](mailto:internationalservicesupport@lifefitness.com)

**Sales/Marketing Email:** [commercialsales@lifefitness.com](mailto:commercialsales@lifefitness.com)

**Operating Hours:** 7:00 am-6:00 pm (CST)

**LATIN AMERICA & CARIBBEAN\*****Life Fitness Inc.**

5100 N River Road, Schiller Park, IL 60176 U.S.A.

**Tel:** (847) 288 3300

**Fax:** (847) 288 3703

**Service Email:** [internationalservicesupport@lifefitness.com](mailto:internationalservicesupport@lifefitness.com)

**Sales/Marketing Email:** [commercialsales@lifefitness.com](mailto:commercialsales@lifefitness.com)

**Operating Hours:** 8:00am-5:00pm (CST)

**BRACTIVITY ZONEIL****Life Fitness Do BrActivity Zoneil**

Av. Dr. Dib Sauaia Neto 1478, Alphaville, Barueri,  
SP 06465-140, BrActivity Zoneil

**Tel:** (800) 773 8282

**Fax:** (+55) 11.4133.2893

**Service Email:** [suporte@lifefitness.com.br](mailto:suporte@lifefitness.com.br)

**Sales/Marketing Email:** [lifefitness@lifefitness.com.br](mailto:lifefitness@lifefitness.com.br)

**Operating Hours:** 8:30 am-17:30 pm (BRT)

**EUROPE, MIDDLE EAST & AFRICA (EMEA)****NETHERLANDS & LUXEMBURG****Life Fitness Atlantic BV**

Bijdorpplein 25-31, 2992 LB Barendrecht, The Netherlands

**Tel:** (+31) 180 646 666**Fax:** (+31) 180 646 699**Service Email:** internationalservicesupport@lifefitness.com**Sales/Marketing Email:** marketing.benelux@lifefitness.com**Operating Hours:** 9.00h-17.00h (CET)**UNITED KINGDOM & IRELAND****Life Fitness UK LTD**

Queen Adelaide, Ely, Cambs, CB7 4UB

**Tel** (General Office): (+44) 1353.666017**Tel** (Customer Support): (+44) 1353.665507**Fax:** (+44) 1353.666018**Service Email:** uk.support@lifefitness.com**Sales/Marketing Email:** life@lifefitness.com**Operating Hours:**

General Office: 9.00am - 5.00pm (GMT)

Customer Support: 8.30am - 5.00pm (GMT)

**GERMANY & SWITZERLAND****Life Fitness Europe GMBH**

Siemensstrasse 3, 85716 Unterschleissheim, Germany

**Tel** (Germany): (+49) 89.31 77 51.0**Tel** (Switzerland): (+41) 0848 000 901**Fax** (Germany): (+49) 89.31 77 51.99**Fax** (Switzerland): (+41) 043 818 07 20**Service Email:** kundendienst@lifefitness.com**Sales/Marketing Email:** kundenberatung@lifefitness.com**Operating Hours:** 9.00h-17.00h (MEZ)**AUSTRIA****Life Fitness Austria**

Vertriebs G.m.b.H., Dückegasse 7-9/3/36, 1220 Vienna, Austria

**Tel:** (+43) 1.61.57.198**Fax:** (+43) 1.61.57.198.20**Service Email:** kundendienst@lifefitness.com**Marketing/Sales Email:** kundenberatung@lifefitness.com**Operating Hours:** 9.00h-17.00h (MEZ)**SPAIN****Life Fitness IBERIA**C/Frederic Mompou 5,1<sup>01</sup><sup>a</sup>,

08960 Sant Just Desvern Barcelona, Spain

**Tel:** (+34) 936 724 660**Fax:** (+34) 936 724 670**Service Email:** info.iberia@lifefitness.com**Sales/Marketing Email:** info.iberia@lifefitness.com**Operating Hours:**

9.00h-18.00h (Monday-Thursday)

8.30h-15.00h (Friday)

**ITALY****Life Fitness ITALIA S.R.L.**

Via Crivellin 7/N, 37010 Affi Verona, Italy

**Tel:** (+39) 045.7237811**Fax:** (+39) 045.7238197**ServiceEmail:** assistenzatecnica@lifefitness.com**Sales/Marketing Email:** info@lifefitnessitalia.com**Operating Hours:** 8.30h -18.00h (CET)**BELGIUM****Life Fitness Benelux NV**

Parc Industriel de Petit-Rechain, 4800 Verviers, Belgium

**Tel:** (+32) 87 300 942**Fax:** (+32) 87 300 943**Service Email:** internationalservicesupport@lifefitness.com**Sales/Marketing Email:** marketing.benelux@lifefitness.com**Operating Hours:** 9.00h -17.00h (CET)**ALL OTHER EMEA COUNTRIES & DISTRIBUTOR BUSINESS CEMEA\***

Bijdorpplein 25-31, 2992 LB Barendrecht, The Netherlands

**Tel:** (+31) 180 646 666**Fax:** (+31) 180 646 699**Service Email:** service.db.cemea@lifefitness.com**Sales/Marketing Email:** marketing.db.cemea@lifefitness.com**Operating Hours:** 9.00h-17.00h(CET)**ASIA PACIFIC (AP)****JAPAN****Life Fitness Japan**

Nippon Brunswick Bldg., #8F

5-27-7 Sendagaya

Shibuya-Ku, Tokyo

Japan 151-0051

**Tel:** (+81) 3.3359.4309**Fax:** (+81) 3.3359.4307**Service Email:** service@lifefitnessjapan.com**Sales/Marketing Email:** sales@lifefitnessjapan.com**Operating Hours:** 9.00h-17.00h (JAPAN)**CHINA AND HONG KONG****Life Fitness Asia Pacific LTD**

Room 2610, Miramar Tower, 132 Nathan Road,

Tsimshatsui, Kowloon, Hong Kong

**Tel:** (+852) 2891.6677**Fax:** (+852) 2575.6001**Service Email:** HongKongEnquiry@lifefitness.com**Sales/Marketing Email:** ChinaEnquiry@lifefitness.com**Operating Hours:** 9.00h-18.00h**ALL OTHER ASIA PACIFIC COUNTRIES & DISTRIBUTOR BUSINESS ASIA PACIFIC\***

Room 2610, Miramar Tower, 132 Nathan Road

Tsimshatsui, Kowloon, Hong Kong

**Tel:** (+852) 2891.6677**Fax:** (+852) 2575.6001**Service Email:** HongKongEnquiry@lifefitness.com**Sales/Marketing Email:** ChinaEnquiry@lifefitness.com**Operating Hours:** 9.00h-18.00h

\* Also check www.lifefitness.com for local representation or distributor dealer



SYMPTOM	POSSIBLE CAUSE	SECTION	PAGE
Belt not moving	Treadmill not powered	Base Frame Electronics	BE 8
	Console operation	Console and Activity Zone	CA 11
	Motor does not start upon workout start	Base Frame Electronics	BE 8
Noise and vibration	From the general striding belt area	Stride System	SS 3
	From the front end of the base	Drive Motor	DS 2
	During incline / decline	Lift System	LS 4
	Structural noise from the base	Lower Frame	LF 2
	Structural noise from the upper frame	Upper Frame	UF 2
Structural failure	Console	Console and Activity Zone	CA 8
	Upper structure	Upper Frame	UF 2
	Base	Lower Frame	LF 2
Appearance issues	Console	Console and Activity Zone	CA 8
	Upper structure	Upper Frame	UF 2
	Base	Lower Frame	LF 2
Error messages	Error message displayed on the console	Error / Info Message Table	Page 163
Heart rate issue	Polar or LifePulse®	Heart Rate System	HR 4
Networking issues	CSAFE connected devices	Console and Activity Zone	CA 8
iPod®, USB and headphone issues	Option panel	Console and Activity Zone	CA 17
Audio and video issues	Console & console connections	Console and Activity Zone	CA 13, CA 20
	Base external connections	Base Frame Electronics	BE 6
User interface issues	Console interface (display, touch screen, etc.)	Console and Activity Zone	CA 18
Software issues	Installed software version is not the latest released	Latest software update Instructions - Look it up here: <a href="https://www.lftechsupport.com/web/guest/software-releases">https://www.lftechsupport.com/web/guest/software-releases</a>	N/A

# *Preparation*

The background is a solid teal color with several large, overlapping, curved bands of a lighter shade of teal. These bands flow from the top right towards the bottom left, creating a sense of movement and depth. The word "Preparation" is written in a white, italicized serif font in the upper left corner.

Unless otherwise specified, these tools are required to perform the service procedures in this manual:

1. Screwdrivers (Phillips and flat blade)
2. Torx bits and drivers
3. Pliers (regular and needle nose)
4. Rubber or dead blow mallet
5. **Snap ring pliers (internal and external)**
6. E-ring tools
7. Socket wrenches (English and metric)
8. Ratchet wrenches (English and metric)
9. Combination, open-end, or box wrenches (English and metric)
10. Allen head wrenches (English and metric)
11. Strap wrench
12. Mini flashlight
13. Scribe or ink pen
14. Straight edge
15. Nut driver (1/4" drive socket set)
16. Removable thread locking compound – e.g. Loctite® 242 or 243
17. **Break Free®**
18. Cord or twine
19. Diagonal cutters (small and medium)
20. 2 blocks (e.g., scrap 4" X 4" [101mm x 101mm] wood)
21. Multimeter with test leads
22. Tape measure
23. Telescoping magnet
24. Stethoscope
25. Calibrated torque wrenches
26. Light lubricating oil (i.e. 3-in-1)
27. TF-1000 grease (White Lithium)
28. Grease gun
29. Grab tool
30. Center punch
31. Anti-static strap
32. Outlet tester
33. Dremel®
34. Drill and extractor (easy-out) Bits
35. Soft cloth

**NOTE:** Specialized tools may be required to complete some service procedures safely. Using tools improperly can result in damage to equipment or personal injury.

### Life Fitness Tools:

1. Bearing removal toolkit [p.n.](#), bearing toolkit [p.n.](#)

**NOTE:** Part numbers are subject to change.

# ***Maintenance***

The background is a solid teal color with several large, overlapping, curved shapes in a lighter shade of teal. These shapes flow from the top right towards the bottom left, creating a sense of movement and depth. The overall aesthetic is clean and modern.

**Preventive Maintenance Schedule**

	ITEM	WEEKLY	MONTHLY	QUARTERLY	BIANNUALLY	ANNUALLY
<b>Display Console / Activity Zone Assembly</b>	Hardware			Inspect for loose or damaged hardware. Replace if necessary. Reapply Loctite 242/243 as needed. Tighten torque bolts to recommended specifications in the Service Manual.		
	Console / Activity Zone overlay	Clean with a mild soap and water, Original Dawn® dishwashing liquid recommended.				
	Accessory cups	Clean with a mild soap and water, Original Dawn® dishwashing liquid recommended. Cups are dishwasher safe.				Inspect for damage, cracking, color fading, etc. Replace if necessary.
	iPod® connector / cable	Clean with dry cloth. Inspect cable and connector for damage.				
	USB port	Clean with dry cloth. Inspect pins for damage.				
	Emergency switch / key	Clean with a mild soap and water, Original Dawn® dishwashing liquid recommended. Inspect for damage. Replace switch if necessary.				

# Preventive Maintenance Schedule

	ITEM	WEEKLY	MONTHLY	QUARTERLY	BIANNUALLY	ANNUALLY
<b>Ergo™ Front Handlebar Assembly</b>	Hardware			Inspect for loose or damaged hardware. Replace if necessary. Reapply Loctite 242/243 as needed. Tighten torque bolts to recommended specifications.		
	Handlebar				Inspect for cracking, color fading, etc. Replace if necessary.	
	Side handrails including shrouds				Inspect for cracking, color fading, etc. Replace if necessary.	
	Bridge cover	Clean with a mild soap and water, Original Dawn® dishwashing liquid recommended using a damp towel, follow up another damp cloth rinsed with clean water to remove any residue. DO NOT scrub or use brushes on the shrouds.			Inspect for cracking, color fading, etc. Replace if necessary.	
	LifePulse® sensors	Clean with a mild soap and water, Original Dawn® dishwashing liquid recommended. Inspect for damage. Replace if necessary.				

**Preventive Maintenance Schedule**

	ITEM	WEEKLY	MONTHLY	QUARTERLY	BIANNUALLY	ANNUALLY
<b>Frame Assembly</b>	Hardware			Inspect for loose or damaged hardware. Replace if necessary. Reapply Loctite 242/243 as needed. Tighten torque bolts to recommended specifications.		
	Uprights and bolts to mount to the lower frame	Clean with a mild soap and water, Original Dawn® dishwashing liquid recommended. Inspect for damage. Replace if necessary.	Inspect for loose or damaged hardware. Replace if necessary. Reapply Loctite 242/243 as needed. Tighten torque bolts to recommended specifications.			
	Motor cover	Clean with a mild soap and water, Original Dawn® dishwashing liquid recommended using a damp towel, follow up another damp cloth rinsed with clean water to remove any residue. DO NOT scrub or use brushes on the shrouds. Inspect for cracking, color fading, etc. Replace as needed.			Inspect for cracking, color fading, etc. Replace if necessary.	



## Preventive Maintenance Schedule

	ITEM	WEEKLY	MONTHLY	QUARTERLY	BIANNUALLY	ANNUALLY
Frame Assembly	Motor electronic compartment		Vacuum interior		Inspect flywheel, drive pulleys cables, connectors, Lift Motor, motor control board, etc. for damage. Use a nylon brush to remove debris. Replace components as needed.	
	Drive belt			Inspect for excessive wear, e.g. cracking, belt debris. Replace as needed.		
	Machine level / leg levelers		Inspect for any rocking on the unit. Adjust as needed.			
	Front roller				Inspect for excessive bearing axial and radial play. Inspect roller for excessive wax buildup. Remove excessive wax buildup. Inspect the plastic drive pulley for cracks, warpage, or missing grooves. Replace components as needed.	
	Rear roller				Inspect for excessive bearing axial and radial play. Remove excessive wax buildup. Replace components as needed.	
	End caps	Clean with a mild soap and water, Original Dawn® dishwashing liquid recommended.	Inspect to see if end caps are damaged, cracked, faded, or loose. Replace if necessary.			

**Preventive Maintenance Schedule**

	ITEM	WEEKLY	MONTHLY	QUARTERLY	BIANNUALLY	ANNUALLY
<b>Frame Assembly</b>	Side shrouds	Clean with a mild soap and water, Original Dawn® dishwashing liquid recommended. Inspect for loose hardware.				
	Side extrusions	Clean with a mild soap and water, Original Dawn® dishwashing liquid recommended. Inspect for loose hardware.				
	Anti-slip pads	Clean with a mild soap and water, Original Dawn® dishwashing liquid recommended. Inspect signs of peeling off.				
	Walking belt	Inspect for belt alignment/tracking and correct accordingly. Inspect the edges of the belt between the belt barriers. Refer to Stride System Module.		Inspect for excessive wear on the walking/running surface and edges for excessive fraying. Replace as needed.		
	Roller guards	Inspect for damage usually caused by users stepping on them. Replace as needed.				
	Visible deck surface	Clean with a mild soap and water, Original Dawn® dishwashing liquid recommended. Inspect for damage. Replace if necessary.				

# ***Modules***

The background is a solid teal color with several overlapping, curved, semi-transparent bands of a lighter shade of teal. These bands create a sense of depth and movement, flowing from the top right towards the bottom left.

# Drive Motor: System Component

M051-00K65-A003

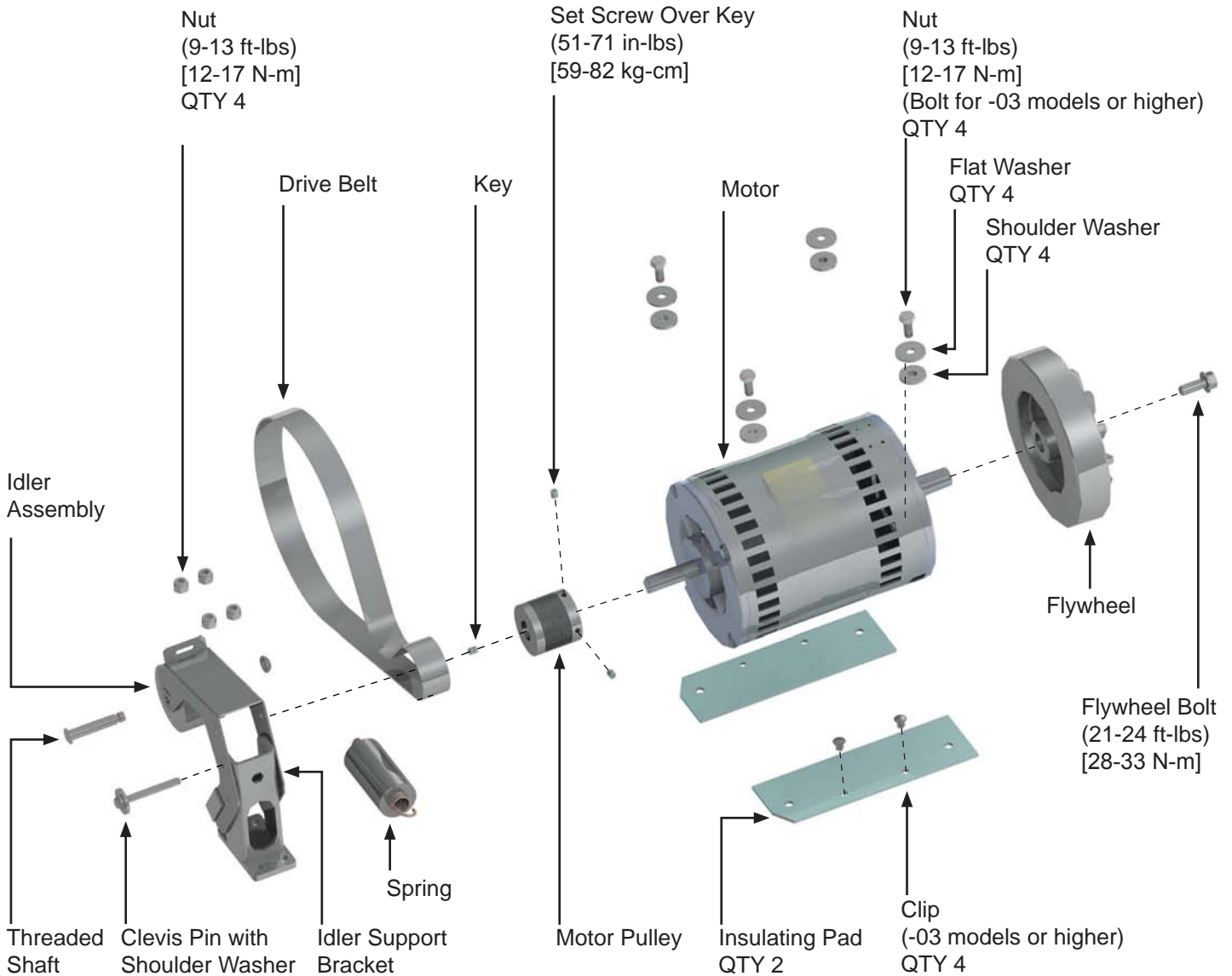

## Drive Motor for -01 and -02 Models

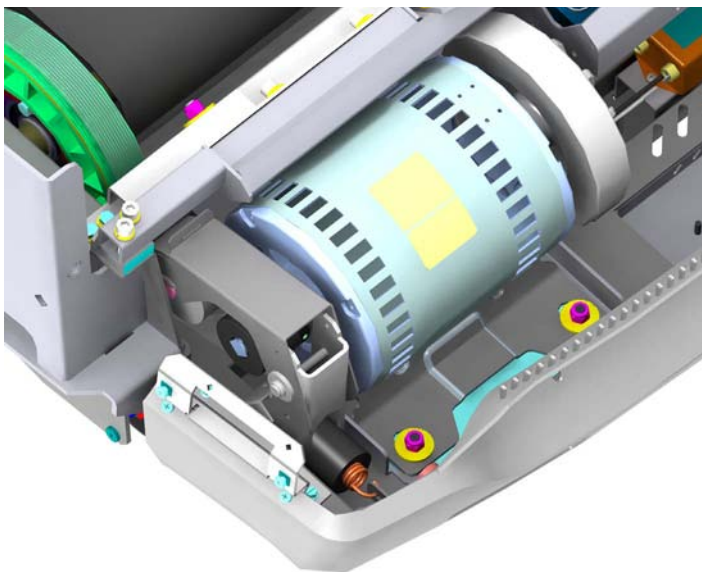

## Drive Motor for -03 and higher

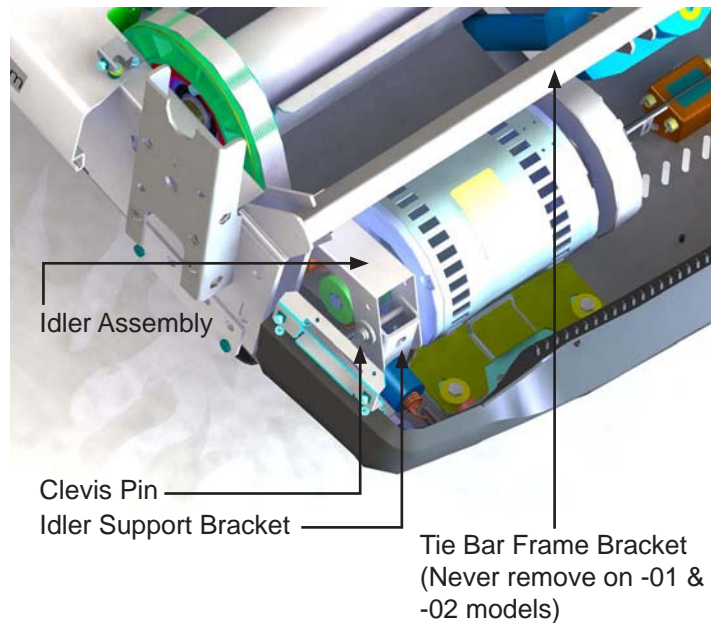

# Drive Motor: Problem Symptoms Table

SYMPTOM	POSSIBLE CAUSE	SECTION	PAGE
Drive motor does not operate.	Drive motor cable connection to controller faulty.	Check drive motor cable connection to controller.	BE 7
	Wrong motor controller for power source (220 volt or 120 volt).	Install proper motor controller.	BE 12
	Failed motor controller.	Verify all connections Replace motor controller if required.	BE 12
	Thermal switch on motor may be open or defective.	Inspect across thermal switch leads with ohm meter (verify not open, and resistance less than one ohm).	
	Is there an error message on the console?	See troubleshooting flowchart.	BE 6
Excessive vibration	Motor flywheel unbalanced.	Replace flywheel.	DS 3
	Motor shaft bent.	Replace motor.	DS 3
	Flywheel bolt loose.	Tighten flywheel bolt.	DS 3
	Motor mounting hardware loose.	Check hardware and tighten accordingly.	DS 3
Squeaking noise when drive belt moves.	Worn or damaged main drive belt.	Inspect main drive belt for damage or wear. Replace if necessary.	DS 3
	Drive motor pulley and front roller pulley misaligned.	Align pulleys.	DS 3
Noise from Drive motor	Motor bearings bad	Replace motor.	DS 3
	Flywheel bolt loose and flywheel rubbing	Tighten flywheel bolt.	DS 3

## Drive Motor: How To's

M051-00K65-A003

### REMOVAL OF DRIVE MOTOR

1. Turn the treadmill power switch off.
2. Unplug the line cord from the wall outlet.
3. Disconnect the cables between the drive motor and the motor controller.
4. Insert a flat blade screwdriver into the slotted end of the idler bracket.
5. Raise idler bracket just enough to insert a screwdriver or an Allen wrench into the access hole of the idler bracket. This will keep it in a raised position.
6. Remove the drive belt from around motor pulley.
7. With the flat blade screwdriver into slotted end of idler, hold on to this screwdriver and slowly remove other screwdriver or Allen wrench.
8. Slowly lower idler bracket with the first screwdriver.
9. Remove spring, clevis pin and idler bracket. Now you are ready to remove motor.

**NOTE:** For -03 models or higher the Idler Support Bracket with the idler assembly must be removed before proceeding to the next step.

10. Remove and save the 4 hex nuts, the 4 washers and the 4 plastic shoulder washers that secure the drive motor to the motor mounting studs in the frame.

**NOTE:** -03 models or higher have bolts instead of nuts.

11. Lift the drive motor assembly up and off the studs and out of the motor pan. (Frames on -03 models or higher have weld nuts instead of weld studs).

**NOTE:** Never remove the tie bar frame bracket on -01 and -02 models.

12. Loosen the set screws on the drive motor pulley (sheave).
13. Remove the pulley from the drive motor.
14. Remove the flywheel/fan assembly by removing flywheel bolt and set aside. Use Tool # AK58-00632-0000 (Part of Tapered Flywheel Removal Kit # GK65-00002-0014).
15. Install the previously removed flywheel/fan assembly and drive pulley (sheave) onto the new drive motor. Do not tighten the drive pulley set screws until the roller pulley and drive pulley have been aligned as shown in the steps that follow.

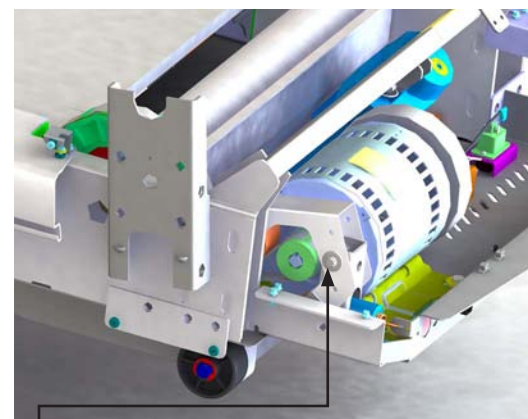
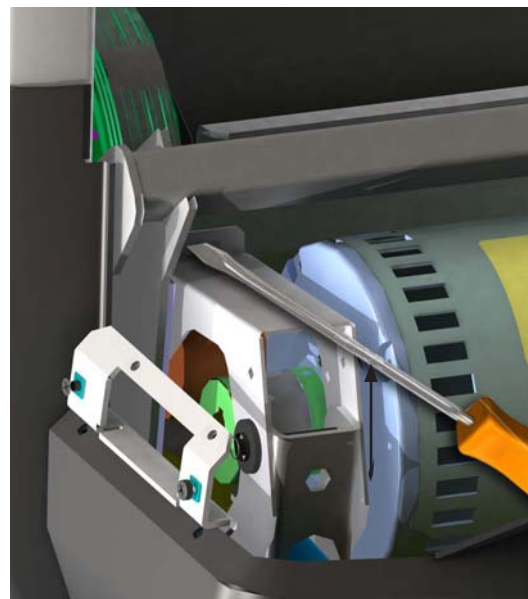

Line up hole in idler and hole in support bracket and insert Allen wrench or screwdriver

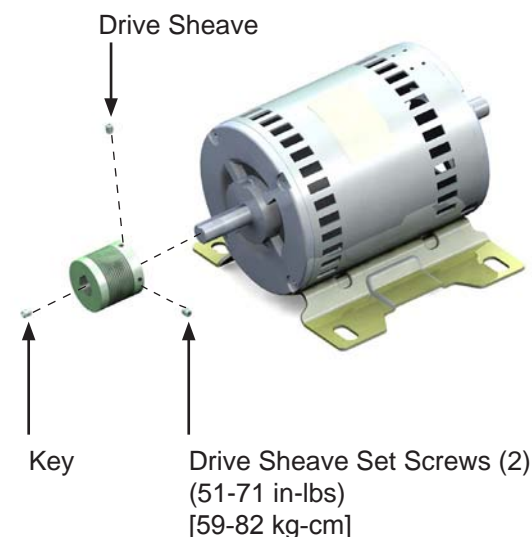

Key

Drive Sheave Set Screws (2)  
(51-71 in-lbs)  
[59-82 kg-cm]

## Drive Motor: How To's

M051-00K65-A003

16. Install the new drive motor. Reuse any hardware removed and saved in previous steps.
17. Slide the drive motor pulley onto the motor shaft and install key into pulley and motor shaft keyway.
18. To align the drive motor pulley (sheave) with the front roller pulley:
  - a. Using a straight edge, align the outer face of the drive motor pulley with the outer face of the front roller pulley.
  - b. Slide the drive motor pulley (sheave) in or out on the shaft during alignment.
  - c. Tighten set screw over the key on the drive motor pulley first. Rotate motor pulley by pushing on the flywheel to make sure pulleys have been properly aligned and belt is running true. Tighten second set screw.

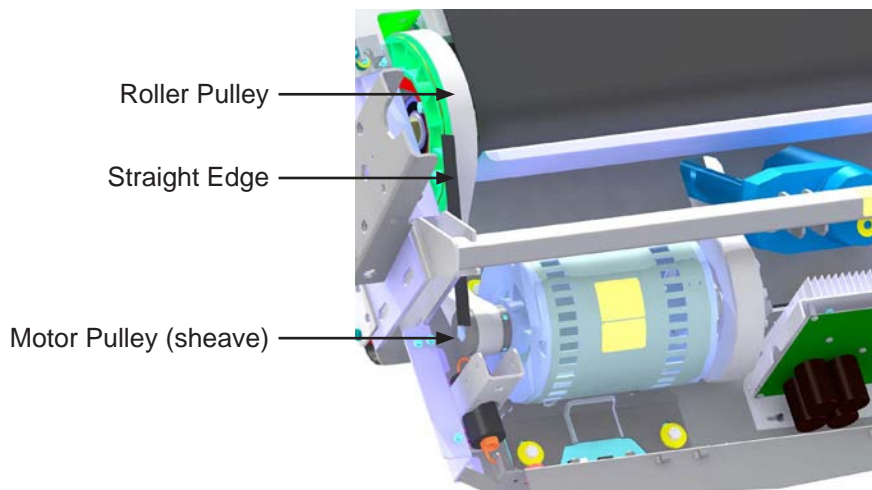

19. Re-install the Idler bracket and drive belt.

## 1. Overview

The electronics in the base of Elevation Series treadmills control the main motor and Lift Motor, provides power to the console and monitors the stride sensor. All the circuitry is contained on a single printed circuit board (PCB) assembly which consists of the PCB plus heatsink and bracket. This DSP Board assembly is known as the "DSP controller" since a Digital Signal Processor (DSP) is at the heart of all the control functions of this board. There are two versions of DSP controller used on Elevation series treadmills, one for low voltage (100-120 VAC) and another for high voltage (200-240 VAC) input power. The input power connector, P7, and the lift actuator connector, P6, are different on the low and high voltage DSP controllers in order to help prevent installing the wrong controller. Another distinguishing feature between the two versions is that FUSE2 and FUSE3 are replaced with jumper wires on the low voltage version since they are only required for European 230 VAC.

## 2. Input Power

The input power comes in from the line cord attached to an IEC connector and is routed through a power switch. After the switch an ElectroMagnetic Inteference (EMI) filter is added to reduce radio frequency conducted emissions. A different filter is used on models meeting European requirements versus models design to meet US requirements. A cable assembly containing transient suppression devices called MOV's or metal oxide varistors is attached to the line filter. These devices help prevent high transient voltage spikes such as from lightning from damaging internal circuitry. The power cable from the filter and MOV then goes to connector P7 on the DSP controller. P7 is a three position connector for 100-120 VAC treadmills and a two position connector for 200-240 VAC treadmills.

On the DSP controller the input power goes through an inrush limiting circuit and an input power relay. The inrush limiting circuit adds series impedance to limit high peak currents when the large DC bus capacitors are being charged at turn on. The input power relay is part of the emergency stop switch system and will remove power to the motor controller stopping striding belt movement when the Emergency Stop Switch (ESS) lanyard is pulled by the user. Both the console and the DSP have control of this relay to turn off power to the motor controller. The power supply remains on and the console will still be powered when this relay is opened.

## 3. Motor Control

The AC power is rectified by BR2 which is mounted to the heatsink and filtered by four large electrolytic capacitors. In the case of the 100-120VAC low voltage DSP controller, a voltage doubler configuration is used so the bus voltage for the motor controller is the same for both high and low voltage versions. The DC bus voltage goes to the IGBT module which is mounted on the heatsink and is the main power stage. This module is configured as a three phase bridge inverter which converts the DC bus voltage to three phase AC voltages at the appropriate amplitude and frequency to run the motor at the correct speed. The motor controller senses the IGBT bridge phase currents and uses this information to calculate the motor speed so a speed sensor is not required.

## 4. Lift Control

The Lift actuator which controls treadmill incline is powered from the DSP controller. The line voltage is switched to either the incline or decline windings of the AC motor depending on which direction is commanded. The DSP controller also reads the Home Switch which tells the DSP the incline is at 0%. The on time of the Lift Motor is controlled to provide the commanded incline. A frequency detect circuit on the DSP controller detects whether the input AC line frequency is 50 Hz or 60 Hz and adjusts the on time to obtain the correct incline.

## 5. Power Supply

The DSP controller contains a flyback power supply that powers the console circuitry as well as all circuitry on the DSP controller. A flyback power supply provides 6 VDC and 12 VDC to the console. These voltages are isolated from the AC line voltage. The same flyback supply also provides supply voltages to the rest of the DSP controller. These voltages are not isolated from AC line but are referenced to the motor controller bus voltage. The power supply is a universal input supply and will operate from 85 VAC to 264 VAC.



## 6. Stride Sensor

The Stride sensor is a piezoelectric sensor placed under the deck which senses movement of the deck. The voltage coming out of the piezoelectric sensor goes to the DSP controller which has an opto-isolator isolating the stride sensor from the DSP. The DSP monitors this voltage and sends the information to the console where it is used to determine the presence of a user.

## 7. Console Interface

The DSP communicates to the console processor via a two wire serial communications. (Note: JW3 should not be present for Elevation treadmills. Other treadmills which use single wire communication will have JW3 in on the DSP controller). Opto-isolators are provided on the DSP controller to isolate the transmit line and receive line since the ground reference for the DSP circuitry is not the same as that of the console. DSP controller software updates can be performed by using it's built in field re-programmability capability directly or via the console Csafe interface.

An additional optically isolated signal the DSP controller receives from the console is the Emergency stop signal which controls the input power relay.

## 8. DSP Controller Software

The Life Fitness motor controller uses proprietary control algorithms to control the ac induction motor to allow for maximum efficiency, noise control and smoothness over the full range of operation.

Onboard sensors monitor bus voltage, motor current and power module temperature ensuring component limits are not exceeded.

Line voltage compensation allows wide voltage fluctuations to be transparent to the exerciser.

Maximum average power is regulated allowing short term peaks while still controlling average power.

Motor Controller diagnostics keep track of 34 parameters and maximums to aid in appraising the health and performance of the system. These combined with indicator LED's help the service technician diagnosing and correcting any system issues.

A serial communication link between the motor controller and Console provides seamless operation of the whole Treadmill system.

## 9. Indicators and Displays

There are ten LED's on the 92343 Polar Board.

- LED1 12V indicator
- LED2 6V indicator
- LED3 Tx Communication indicator
- LED4 Lift (Up) direction
- LED5 Lift ON
- LED6 V bus indicator
- LED7 +Vd indicator
- LED8 3.3V indicator
- LED9 Incline 0 position indicator
- LED10 Incline Bottom position indicator

## 10. Connector

Connector P1 is a six position female Mate-N-Lock connector for motor.

PIN #	DESCRIPTION
P1-1	Frame
P1-2	Phase W
P1-3	Phase V
P1-4	Phase U
P1-5	Not Used
P1-6	Not Used

Connector P4 is a four position Micro-fit connector for limit switches.

PIN #	DESCRIPTION
P4-1	Zero position switch
P4-2	Zero position switch return (GND)
P4-3	Bottom limit switch
P4-4	Bottom limit switch return (GND)

Connector P5 is a ten position Mini-fit jr. for console power and signals.

PIN #	DESCRIPTION
P5-1	RTN
P5-2	RTN
P5-3	6VDC (Elevation); 8VDC (Classic)
P5-4	6VDC (Elevation); 8VDC (Classic)
P5-5	12V (Elevation); N.C. (Classic)
P5-6	RXD
P5-7	TXD
P5-8	N.C.
P5-9	12VDC
P5-10	ESS

Connector P6 is four position Mate-N-Lock connector for lift actuator.

PIN #	DESCRIPTION
P6-1	Down
P6-2	Hot
P6-3	Up
P6-4	N.C.

Connector P7 is a three position Mini-fit Senior connector for input power.

PIN #	DESCRIPTION
P7-1	Line
P7-2	Neutral
P7-3	Not used

Connector P8 is a 2 position Mini-fit Jr. for motor thermal switch.

PIN #	DESCRIPTION
P8-1	Therm1
P8-2	Therm2

Connector P9 is a five position Mini-Fit Jr. connector for console voltage select.

PIN #	DESCRIPTION
P9-1	8V
P9-2	6/8V
P9-3	6V
P9-4	12V
P9-5	12V(ESS)

Connector P10 is a 3 position C-grid connector for Stride Sensor interface.

PIN #	DESCRIPTION
P10-1	RTN
P10-2	SSENSE
P10-3	+12VDC

Connector P14 6 position KK100 Test connector.

PIN #	DESCRIPTION
P14-1	N.C.
P14-2	N.C. (key)
P14-3	GND
P14-4	+Vd (15Vdc) Internal Supply
P14-5	3.3V Internal Supply
P14-6	Reset

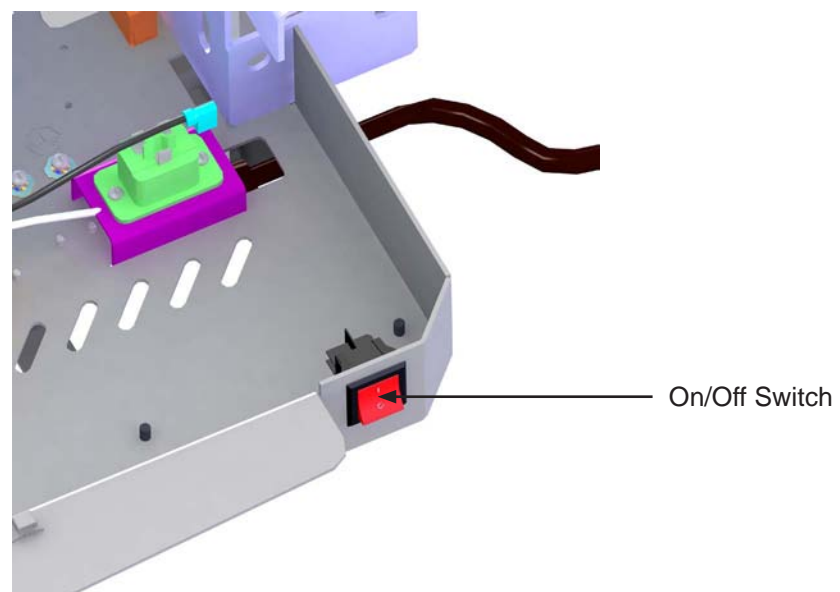
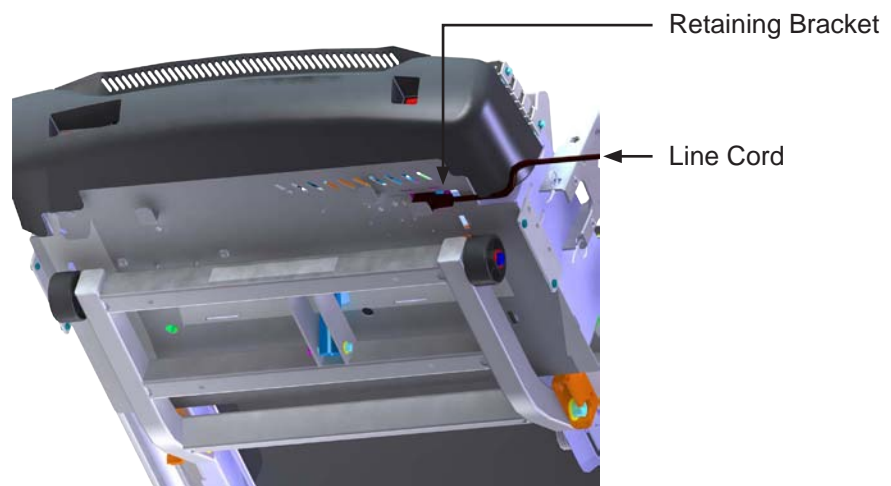
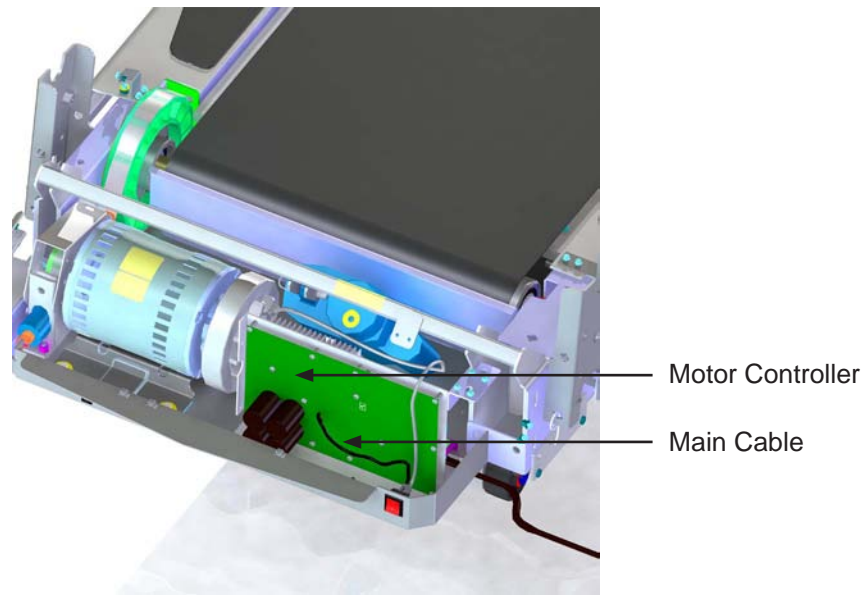

## Base Frame Electronics: Problem Symptom Table

M051-00K65-A003

SYMPTOM	POSSIBLE CAUSE	SECTION	PAGE
No power to treadmill	Open or failure in line cord, cables, controller, etc.	See flow chart.	BE 8
Maximum speed is reduced or error message "Cannot attain target speed".	Insufficient line voltage.	Refer Stride System Module.	SS 3
	Worn deck and/or worn striding belt.		
Unit resets randomly Or pauses.	Intermittent in line cables, stop switch circuit.	See flow chart.	BE 10
Error message "Module Communication Error".	Power up Communication test to base failed or lost communication with base.	Check/replace cabling down to the M/C.	
Error message "Notify maintenance communication timeout (motor controller)".	Broken communication lines, JW3 installed on DSP M/C.	Remove JW3. Check/replace cabling down to the M/C. Vibration is causing intermittent operation from loose connection.	
Error message "Notify maintenance motor controller error (thermal shutdown)".	The M/C compartment airflow is restricted. Hot air is being blown on it. It's located in direct sunlight. There is excessive wear on the belt or deck.	Clean the M/C compartment. Insure adequate ventilation is available and it is not being heated by a heating register. Move from direct sunlight. Replace belt/deck if power level is excessive.	
Error message "Warning – step off belt, maximum voltage trip".	User is driving the belt with sufficient energy to raise the bus voltage, most likely at high inclines. Input line has voltage surge problems.	Instruct the user to stop driving the belt at high inclines, or to use a lower incline. Contact an electrician to diagnose/correct a power line problem.	
Error message "Notify maintenance motor controller error (hardware current trip)".	Excessive motor current caused by a failed motor, intermittent motor or motor connection(s). A possible but unlikely cause would be a severely worn belt/deck.	Verify that all motor connections and cables are solid. If start-up power is very weak a phase may be faulty. Perform a phase test to verify the system or diagnose a phase problem.	
Error message "Notify maintenance Motor controller error (low voltage detected)	Line cord is not securely plugged into the wall or machine. Loose/intermittent receptacle wiring. Machine is not plugged into a proper dedicated line. Incoming voltage is fluctuating dipping to an insufficient level.	Check that the cord is solidly plugged into the wall receptacle and also into the machine. Contact an electrician to diagnose/correct a power line problem.	

# Base Frame Electronics: Problem Symptom Table

SYMPTOM	POSSIBLE CAUSE	SECTION	PAGE
Error message "Start up error"	Motor unplugged or connector loose. A possible but unlikely cause would be the user driving the belt at startup.	Verify that the motor connections are solid. Perform a phase test to verify the system or diagnose a phase problem.	
Error message "Motor disabled"	An intermittent console/ motor controller cable or emergency stop switch.	Confirm that all connections are solid, all wires are properly seated into the connector and that the cable is not pinched and being shorted/open. Verify proper operation of the emergency stop switch.	
Error message "Incline inoperative – continue if desired"	Improper home or decline switch operation/ adjustment/cable. Incline motor connection unplugged/loose. A possible but unlikely cause would be incline motor overheating from excessive operation.	Verify that all motor and switch connections and cables are solid. Verify incline switch operation using diagnostic switch LEDS (LED 9&10). Verify incline motor activation using diagnostic LEDS (LED 4&5). Re-adjust or replace switches/ cables.	
Line cord inoperative	Damaged	Check connections.	
	Not connected	Replace line cord.	
Main cable inoperative	Damaged	Replace main cable.	
	Not connected		
Motor controller inoperative	Damaged	Replace motor controller board.	
	Not connected		
On/Off switch inoperative	Damaged	Replace On/Off switch.	
	Not connected		
Line filter inoperative	Damaged	Replace line filter.	
	Not connected		
IEC receptacle in inoperative	Damaged	Replace IEC receptacle.	
	Not connected		

**No Power on Treadmill**

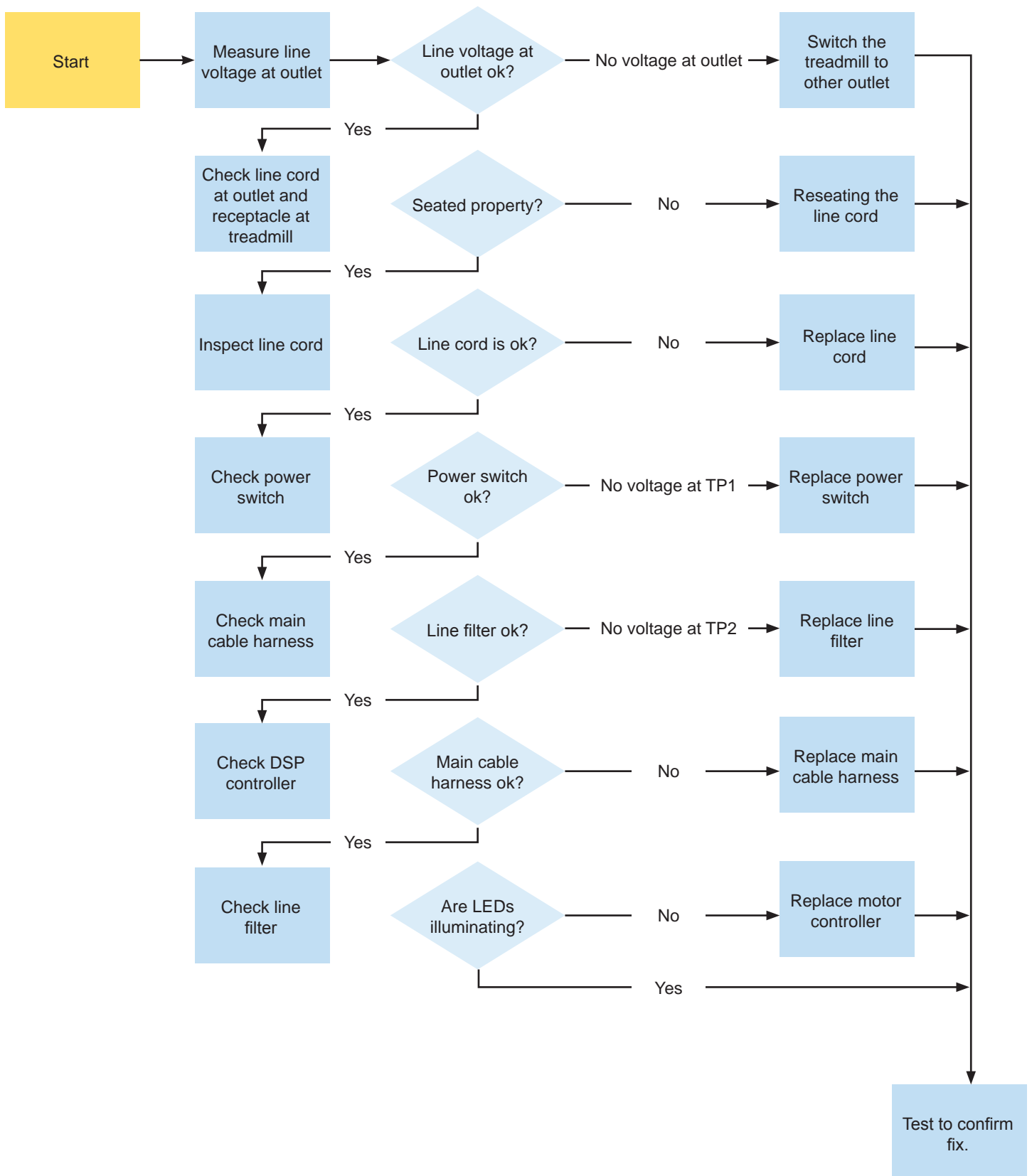

Reduce Maximum Speed

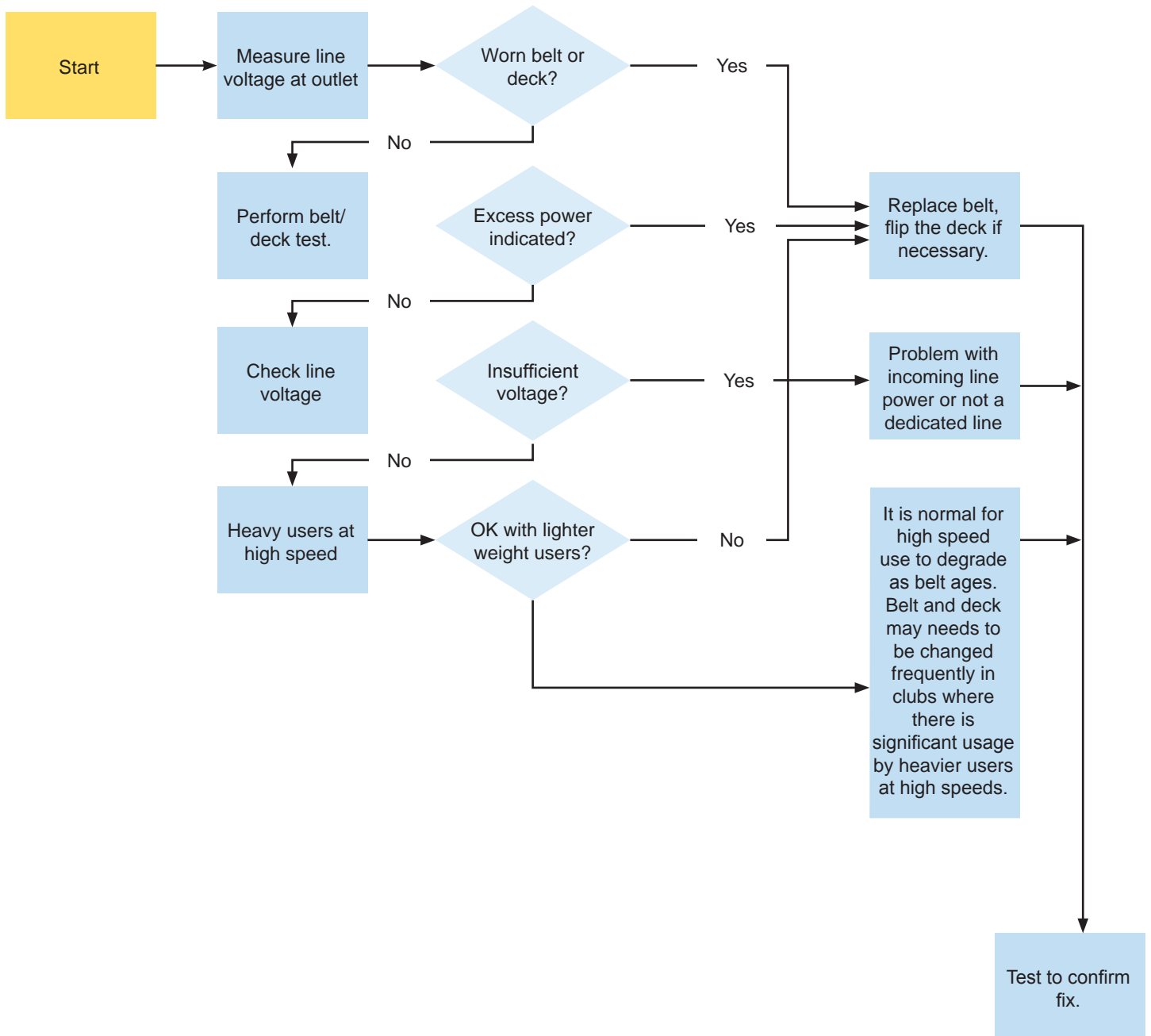



Treadmill Pauses or Reset Randomly

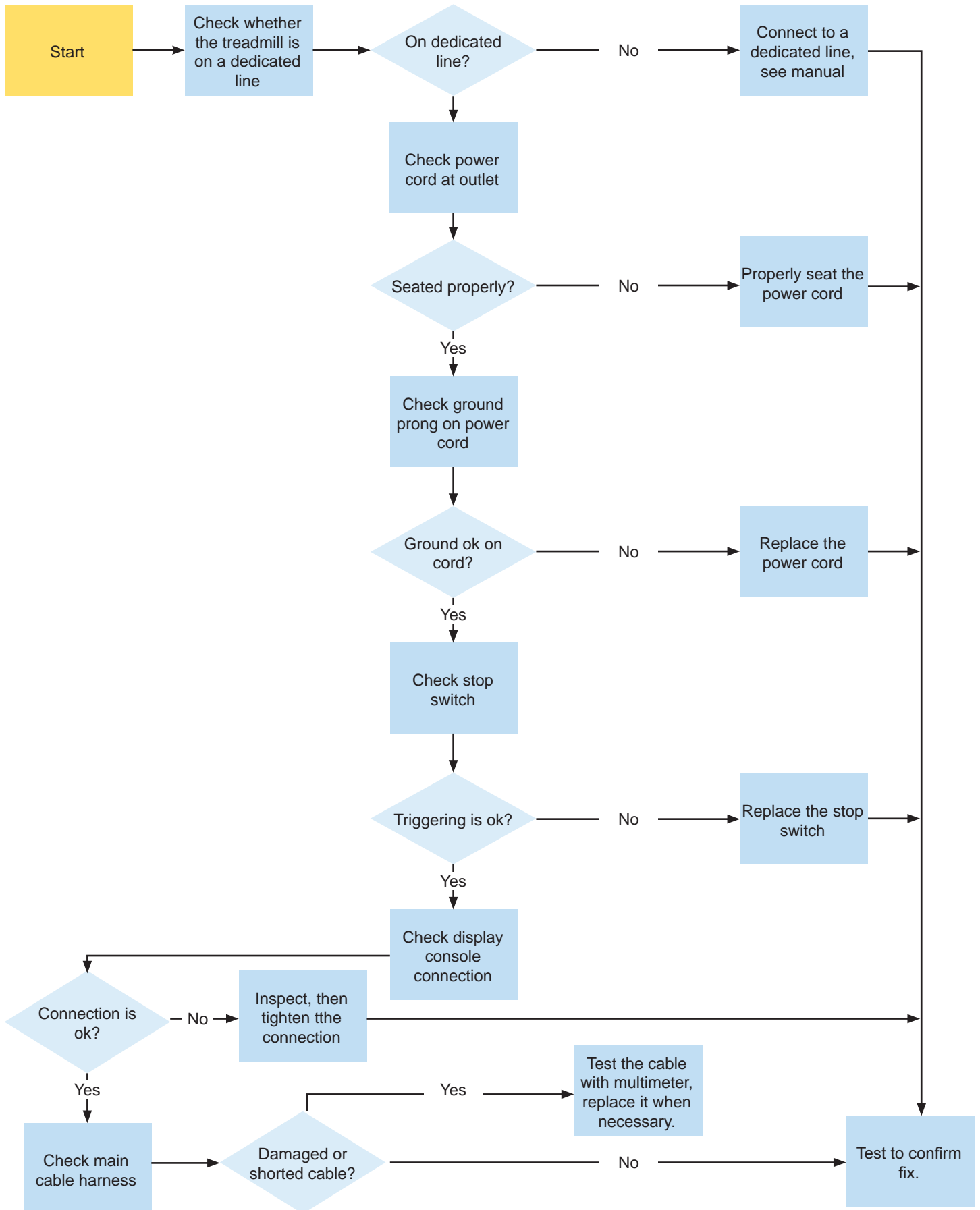

**REPLACEMENT OF LINE CORD**

1. Turn the treadmill power switch off.
2. Unplug the line cord from the wall outlet.
3. Lift the front end of the treadmill approximately 4 inches off the floor and place a block of wood underneath both sides to support it.
4. Remove and save the two screws that secure the line cord retaining bracket to the motor pan.
5. Unplug the defective line cord.
6. Install the new line cord, using the screws removed and saved in Step 4.

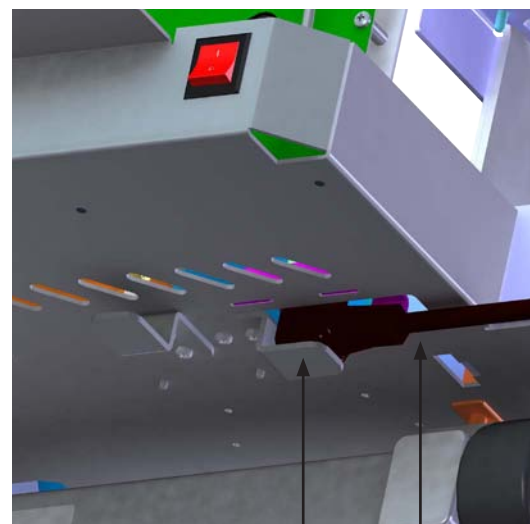

Retaining Bracket      Line Cord

**REPLACEMENT OF MAIN CABLE**

1. Turn the treadmill power switch off.
2. Unplug the line cord from the wall outlet.
3. Remove the top motor cover (See [LF 3](#)).
4. Remove the Activity Zone assembly (See [CA 22](#)).
5. Remove the lower bridge cover (See [UF 4](#)).
6. Disconnect one end of the main cable from the motor controller.
7. Disconnect the cable between the top of the left upright and the console.
8. Pull the main cable out of the left upright.
9. Install the new main cable.

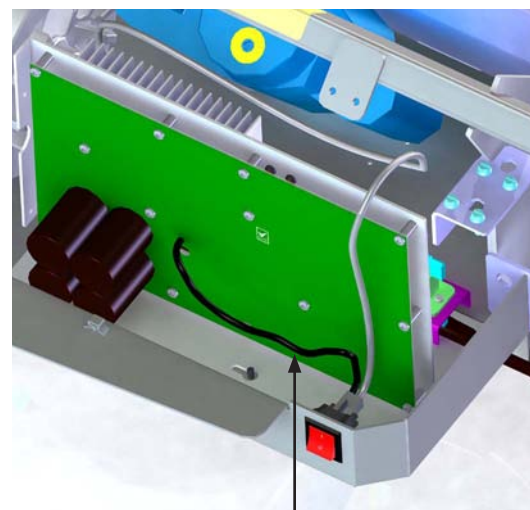

Main Cable

12-18 lb\*in  
[13.8-20.7 kg\*cm]



Added torque

**REPLACEMENT OF MOTOR CONTROLLER (DSP)**

1. Turn the treadmill power switch off.
2. Unplug the line cord from the wall outlet.
3. Remove the top motor cover (See [LF 3](#)).
4. Record the cable connection locations.
5. Remove the lower bridge cover (See [UF 4](#)).
6. Loosen the three hex nuts that secure the motor controller to the motor pan.
7. Remove and save the two bolts that secure the motor controller bracket to the Lift Motor bracket.
8. Remove the motor controller.
9. Install the new motor controller using hardware saved in the previous steps.

**Recommended Tools:**

Phillips screwdriver, 8 mm socket, long ¼" extension, ¼" ratchet

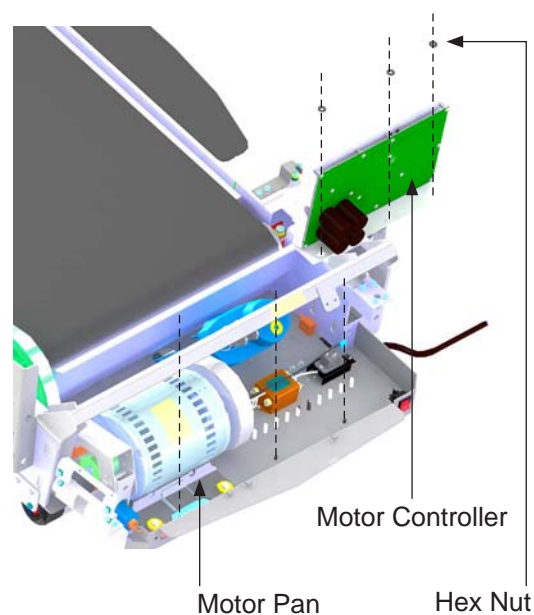

12-18 lb\*in  
[13.8-20.7 kg\*cm]

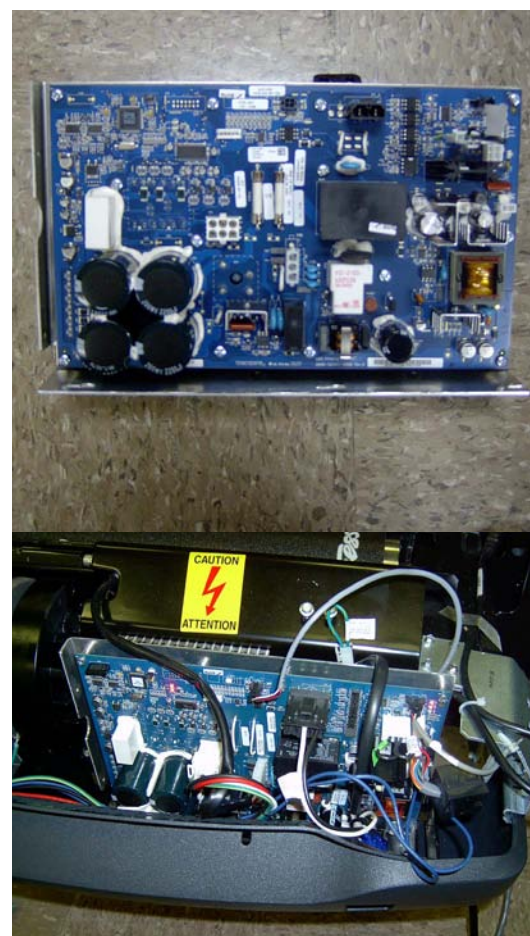

**REPLACEMENT OF THE ON/OFF SWITCH**

1. Turn the treadmill power switch off.
2. Unplug the line cord from the wall outlet.
3. Remove the top motor cover (See [LF 3](#)).
4. Record the location of wire connections to the on/off switch.
5. Disconnect the wires. Use needle nose pliers if necessary. (You may need to remove the motor controller to allow more room to access the on/off switch.).
6. Squeeze the tabs on the top and bottom of the on/off switch and push out from inside the frame.
7. Install the new on/off switch.

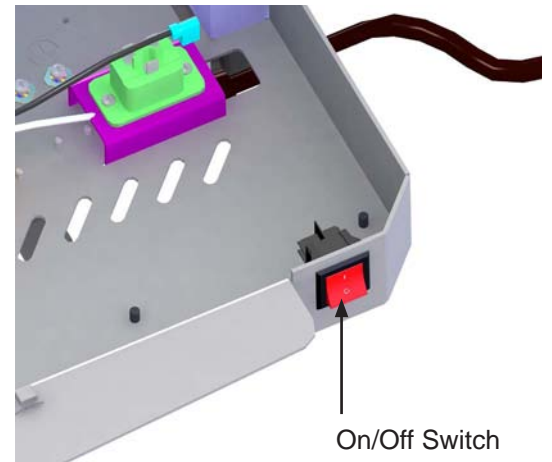
**REPLACEMENT OF LINE FILTER**

1. Turn the treadmill power switch off.
2. Unplug the line cord from the wall outlet.
3. Remove the top motor cover (See [LF 3](#)).
4. Remove the motor controller.
5. Record the location of the wires connected to the line filter.
6. Remove the wires.
7. Remove and save the two Philips screws that secure the line filter to the motor pan assembly.
8. Remove the line filter.
9. Install the new line filter, using the hardware saved in Step 7.

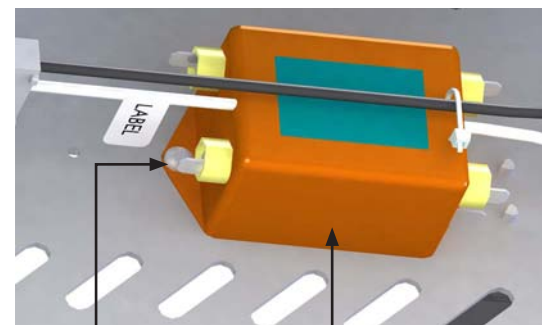

Philips Screw (1 of 2)

Line Filter

12-18 lb\*in  
[13.8-20.7 kg\*cm]



**REPLACEMENT OF IEC RECEPTACLE**

1. Turn the treadmill power switch off.
2. Unplug the line cord from the wall outlet.
3. Lift the end of the treadmill about four inches off the floor and place blocks of wood under both sides to support it.
4. Remove and save the two screws that secure the line cord retaining bracket to the motor pan. Set the retaining bracket aside.
5. Unplug the line cord from the unit and save.
6. Remove the top motor shroud cover (See [LF 3](#)).
7. Remove the motor controller.

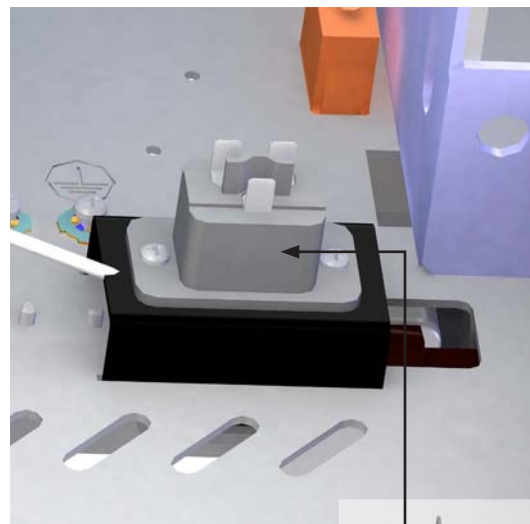

12-18 lb\*in  
[13.8-20.7 kg\*cm]

IEC Receptacle

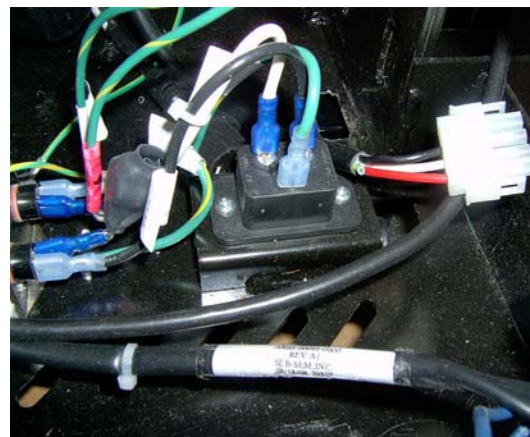

DSP Controller Block Diagram

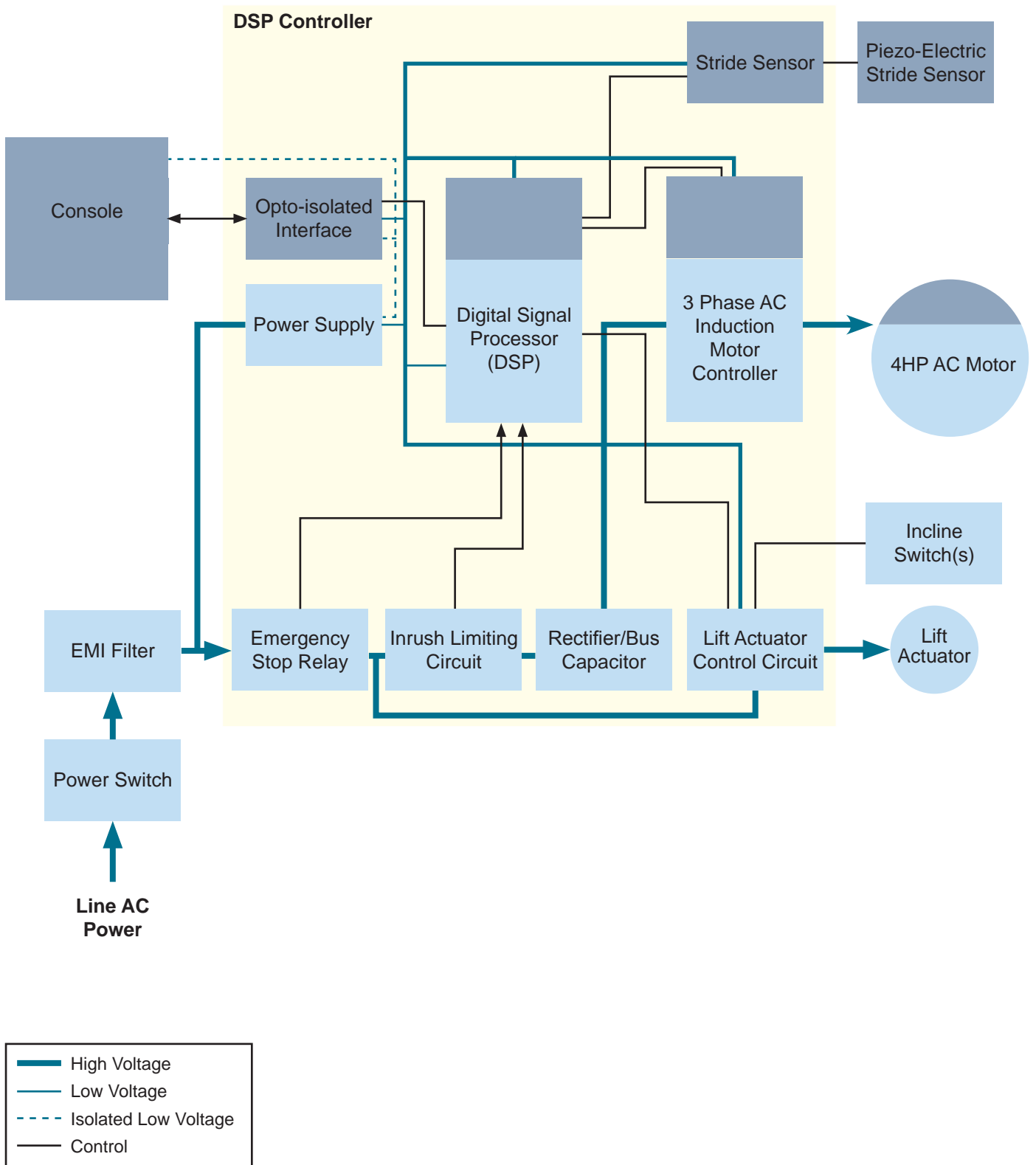

**DSP Controller Functional Description**

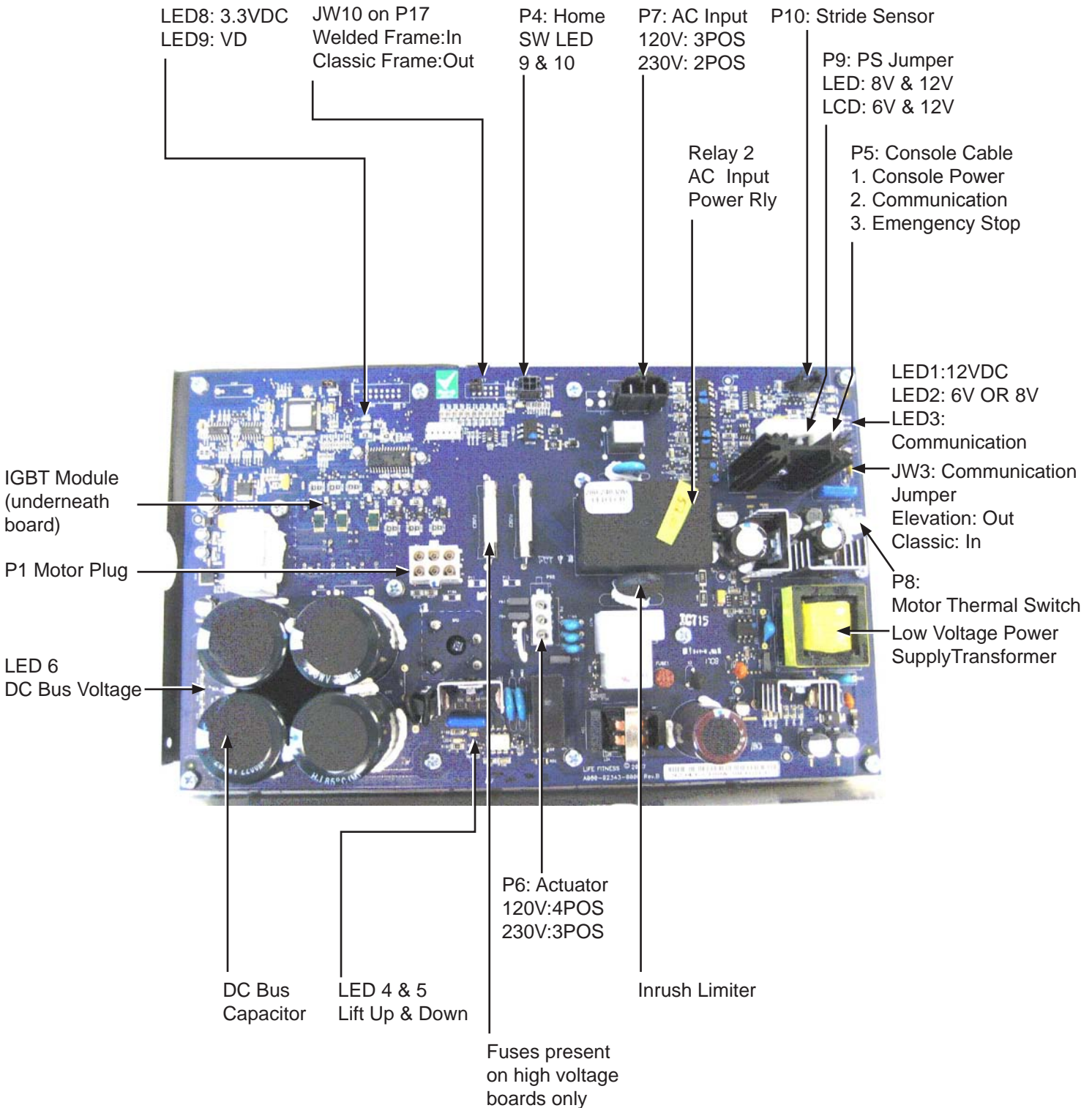

# Base Frame Electronics: Electrical Wiring Diagrams

M051-00K65-A003

## Base Electronics Wiring Diagram

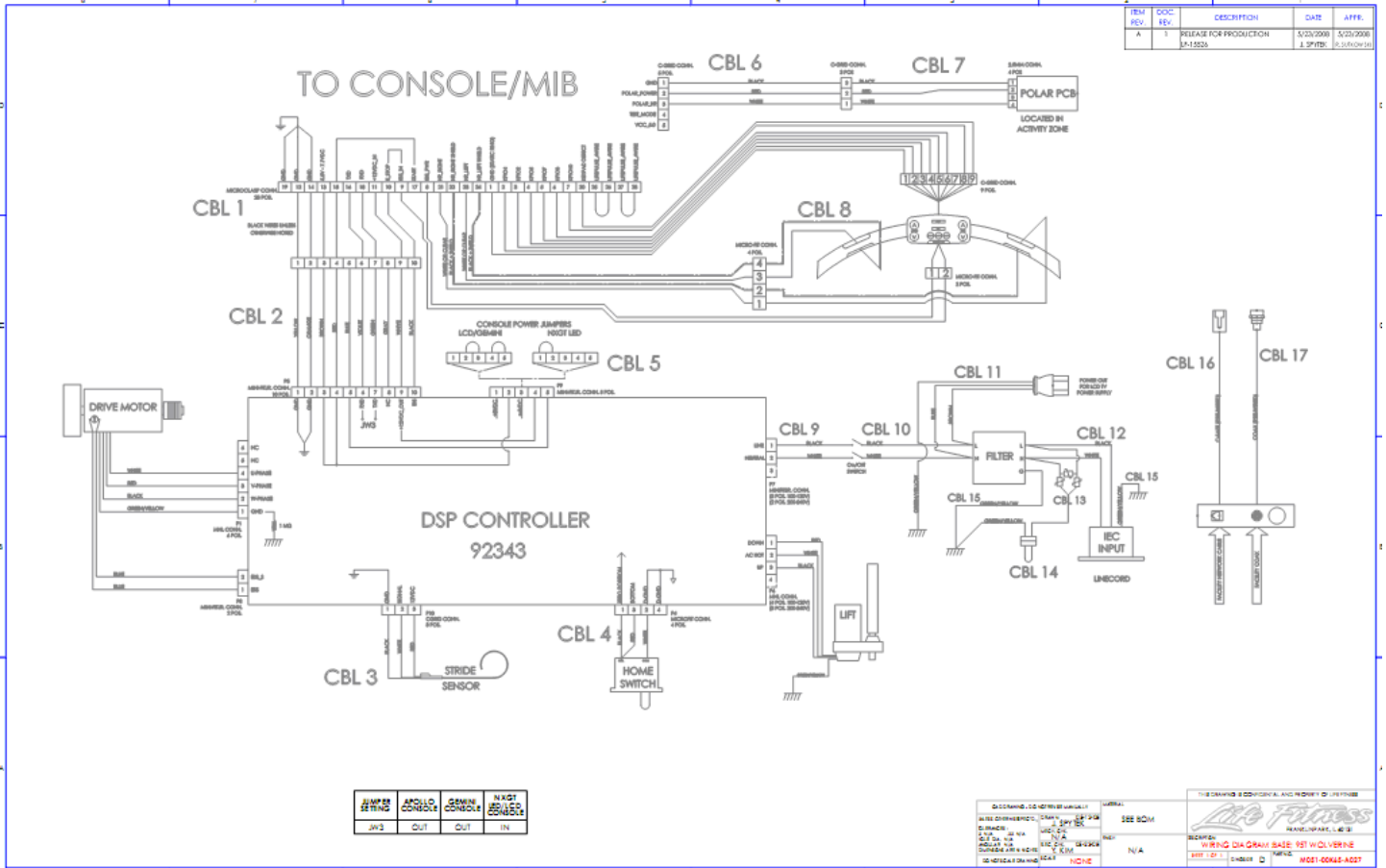



## Lift System: Theory of Operation

M051-00K65-A003

---

The Lift Motor System is comprised of the Lift Motor, the lift frame and the Home Switch. (see page LS-4)

In order for the lift system to be operational, the Emergency Stop Switch located on the console area must be properly engaged. The Lift Motor is pinned to the Lift Motor support bracket on the treadmill frame on one end and is pinned on the other end to the lift frame. The Lift Frame is also pinned to the treadmill frame. (see page LS-4)

The Lift Motor consists of a gear box, a steel ACME screw and a steel tube. The steel tube has an engineered plastic nut that is fixed on one end of the tube. The ACME screw is pinned to the output gear on the gear box on one end and screws into the nut on the steel tube on the other end. As the ACME screw rotates the steel tube extends or retracts which raises or lowers the treadmill. There are internal limits switches on the gearbox to prevent over-travel.

The Lift Motor is programmed to incline the treadmill up to 15% at 0.5% increments. The desired incline is commanded through the incline up or down arrows or through the keypad on the console. When a user first starts the treadmill the Lift Motor will lower the treadmill until the Home Switch is activated (this is 0% incline or **level**) unless the treadmill is already at 0% incline. If the Home Switch cannot be activated, the console will display a message after a given duration, stating "incline inoperative continue if desired".

One way of determining if a Lift Motor or a Home Switch is electrically defective is by observing whether or not certain LED's on the motor controller light up. Similarly, knowing that both the Lift Motor and the Home Switch are electrically good and the LED's do light up but the treadmill is not able to be inclined or lowered may be an indication that the Lift Motor is mechanically defective or the controller is bad. These tests are described in detail in the Base Electronics (BE) section.

# Lift System: System Components

## Cross-section View Of Lift System (-01 And -02 Models Only)

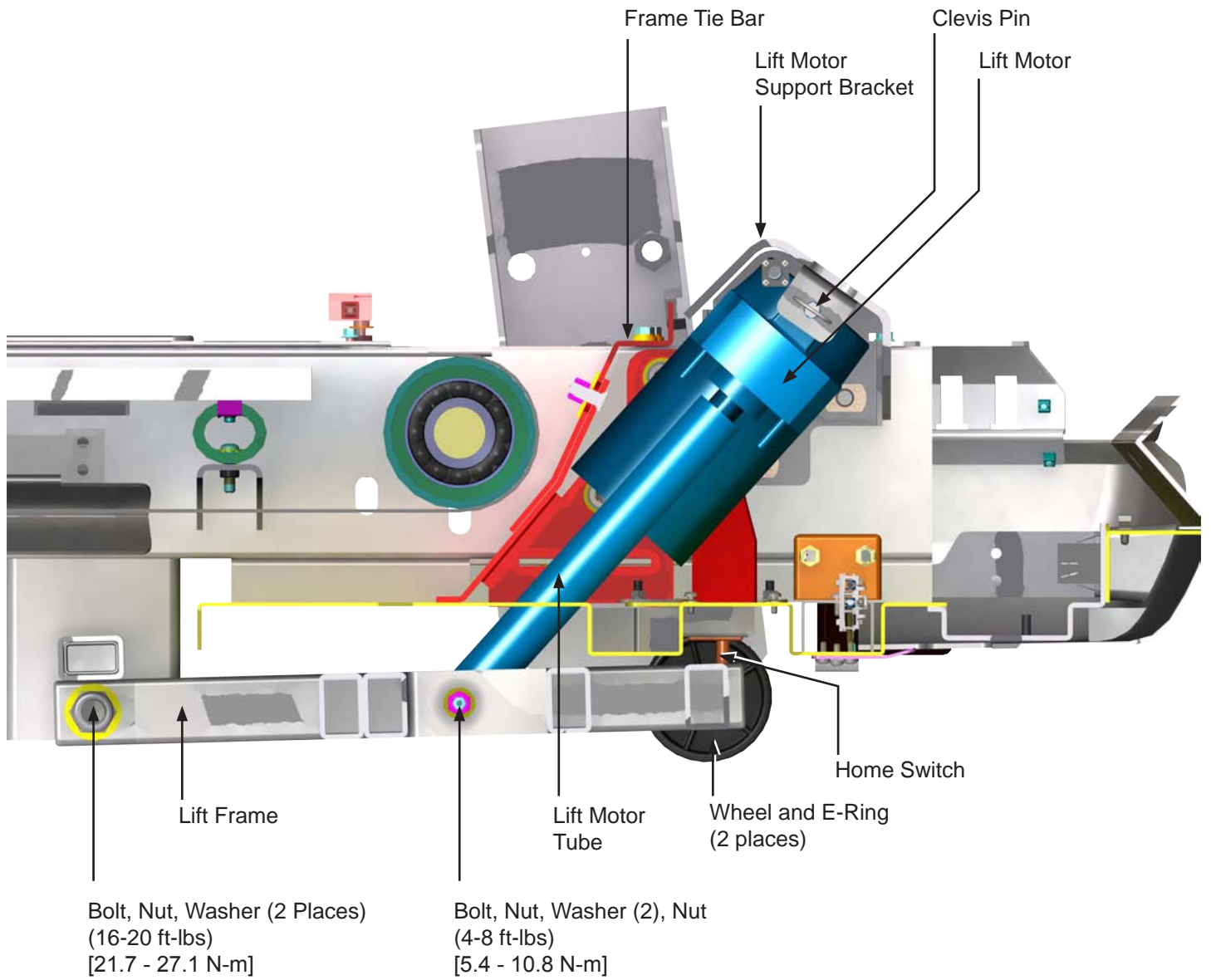

## Cross-section View Of Lift System (-03 Models And Higher)

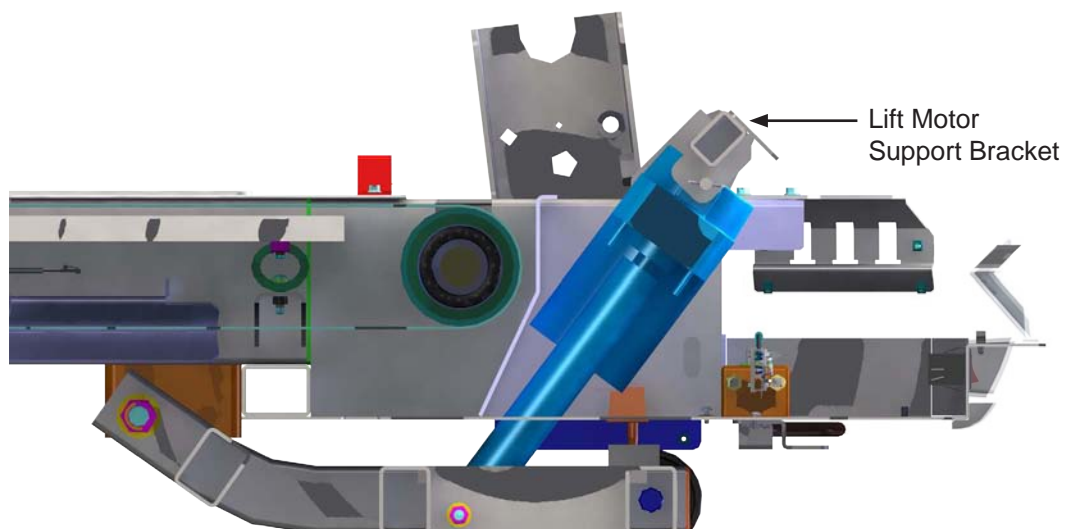

# Lift System: System Components

M051-00K65-A003

## Lift System (-01 And -02 Models Only)

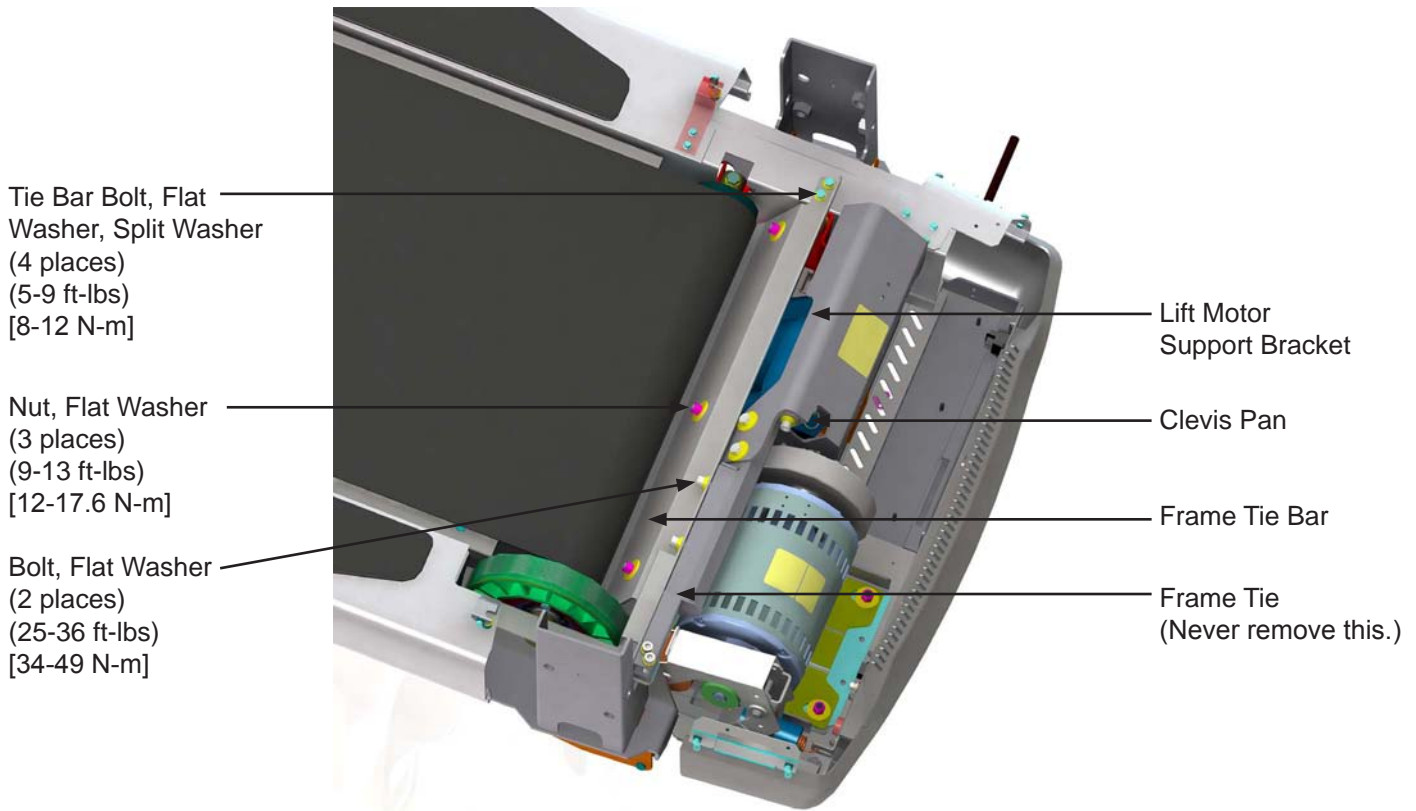

## Lift System (-03 Models And Higher)

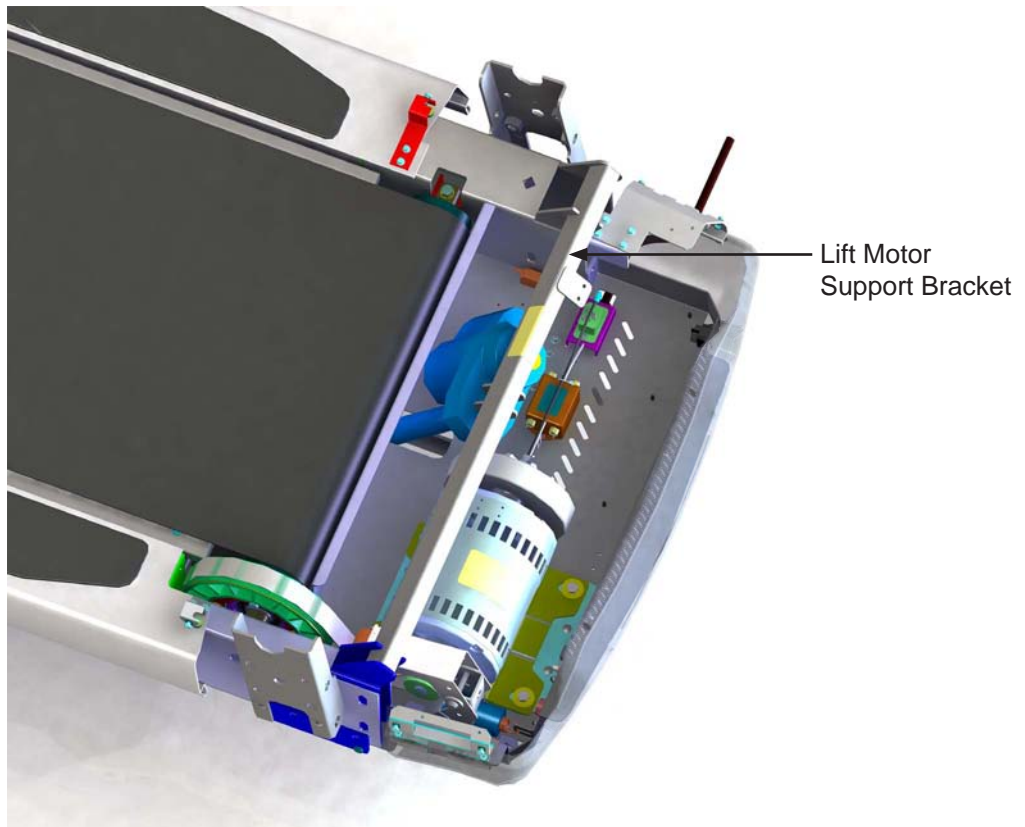

# Lift System: Problem Symptom Table

SYMPTOM	POSSIBLE CAUSE	SECTION	PAGE
Lift Motor does not raise or lower unit.	Broken internal components in Lift Motor gear box (motor runs but ACME screw does not).	Replace Lift Motor.	LS 6
	Thermal cutout switch open due to overheating of Lift Motor.	Allow Lift Motor to cool for 15 minutes and confirm proper operation, Otherwise replace Lift Motor.	LS 6
	Broken/worn plastic nut on Lift Motor tube (ACME screw rotates but does not raise unit).	Replace Lift Motor.	LS 6
	Failed clevis pin or failed mounting bolt.	Replace mounting bolt or clevis pin.	LS 6
	Emergency stop switch is removed.	Install emergency stop switch.	
	Motor controller lift circuit failure.	Perform test on motor controller #4 and #5 LED and replace Lift Motor if LED's do not light up.	
Lift Motor does not raise unit.	Unit cannot find Home Switch due to improper installation which causes Lift Motor to bottom out before activating Home Switch.	Remove and re-install Lift Motor at proper extended length.	LS 6
	Home Switch not connected.	Connect Home Switch cable.	LS 9
	Faulty Home Switch.	When Home Switch is manually pressed the #9 LED on the controller should be ON. If not check cable and replace Home Switch if required.	LS 9

**Lift System: Problem Symptom Table**

M051-00K65-A003

SYMPTOM	POSSIBLE CAUSE	SECTION	PAGE
Lift Motor operates intermittently.	Overheating of Lift Motor.	Replace Lift Motor.	LS 6
	Broken internal components in Lift Motor gear box (ACME screw rotates intermittently while motor is running).	Allow Lift Motor to cool for 15 minutes and confirm proper operation, Otherwise replace Lift Motor.	LS 6
	Failed clevis pin or mounting bolt causing Lift Motor to sit at an angle.	Inspect clevis pin and mounting bolt.	
Difficult to move unit with lift frame wheels.	Lift frame wheels flattened due to wear or broken or cracked.	Replace wheels.	

**REMOVAL OF LIFT MOTOR**

1. Turn the treadmill power switch off.
2. Unplug the line cord from the wall outlet.
3. Disconnect Lift Motor connector from motor controller.
4. Remove Frame Tie Bar (-01 and -02 models only).

**NOTE:** Do not remove any other frame brackets

5. Disconnect Lift Motor ground wire.
6. Turn unit on its side.

7. Remove Lift Motor lower pivot hardware.

Tie Bar on -01 and -02 models only

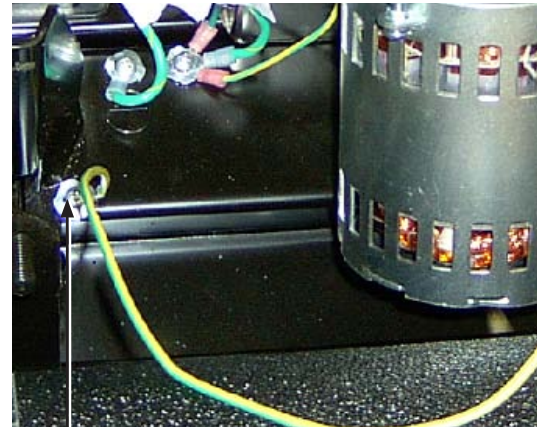
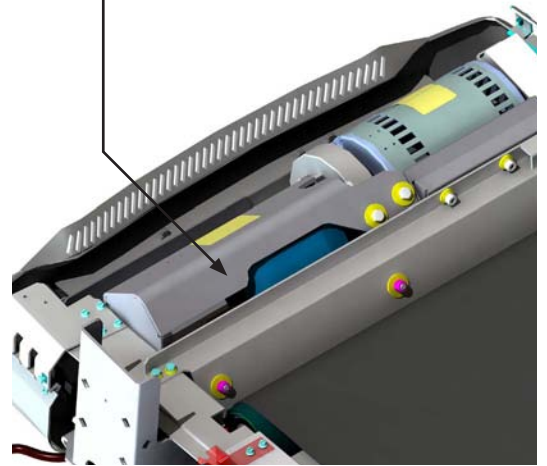

Ground Screw  
(12-18 in-lbs)  
[1.3-2 N-m]

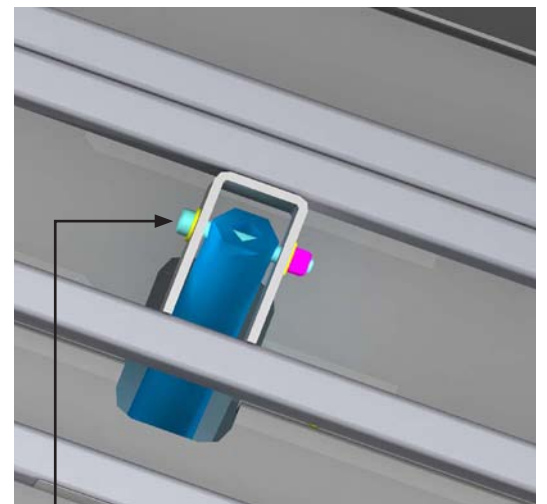

(4-8 ft-lbs)  
[5.4-10.8 N-m]

# Lift System: How To's

8. Remove Clevis Pin. Remove Lift motor
9. Install new Lift Motor and hold in place with Clevis Pin.

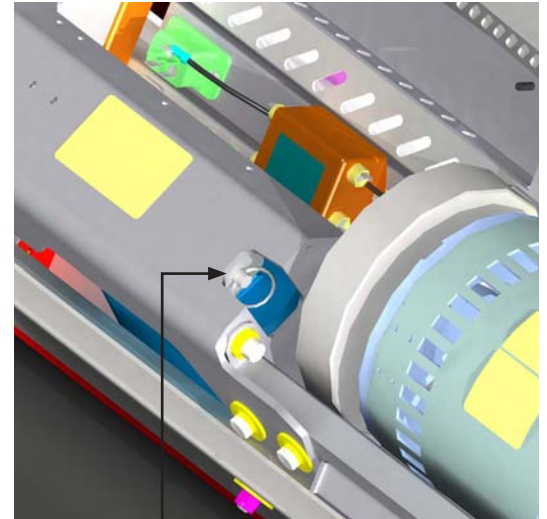

Clevis Pin

10. Align hole in Lift Motor Tube with pivot hole in lift frame so that Home Switch is actuated. (Listen/feel for actuation of Home Switch)

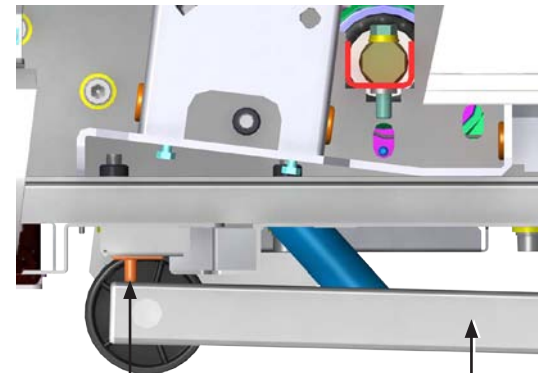

Home Switch

Lift Motor Lower Pivot

11. Install Lift Motor lower pivot hardware.
12. Turn unit upright.
13. Connect ground wire and plug in Lift Motor connector to motor controller.
14. Power up unit and test travel.
  - a) When unit is powered up, unit must find Home Switch and then stop.
  - b) Command 15% incline and wait until inclining stops. Depress Home Switch. Unit should incline momentarily and quickly stop. If this occurs, the Lift Motor has reached its internal limit switch and is operating properly. If unit does not incline momentarily implies that internal limit switch was reached before unit was able to reach 15% incline.

Go back to Step 10 and adjust Lift Motor tube pivot to lift frame pivot by turning Lift Motor tube clockwise and repeat above test steps.



(4-8 ft-lbs)  
[5.4-10.8 N-m]

# Lift System: How To's

M051-00K65-A003

## REMOVAL OF LIFT FRAME

1. Turn unit on its side and lay against upright frame.
2. Remove Lift Motor lower pivot hardware.
3. Remove Lift Frame pivot hardware.
4. Remove E-Ring to remove wheels.
5. Install new lift frame.

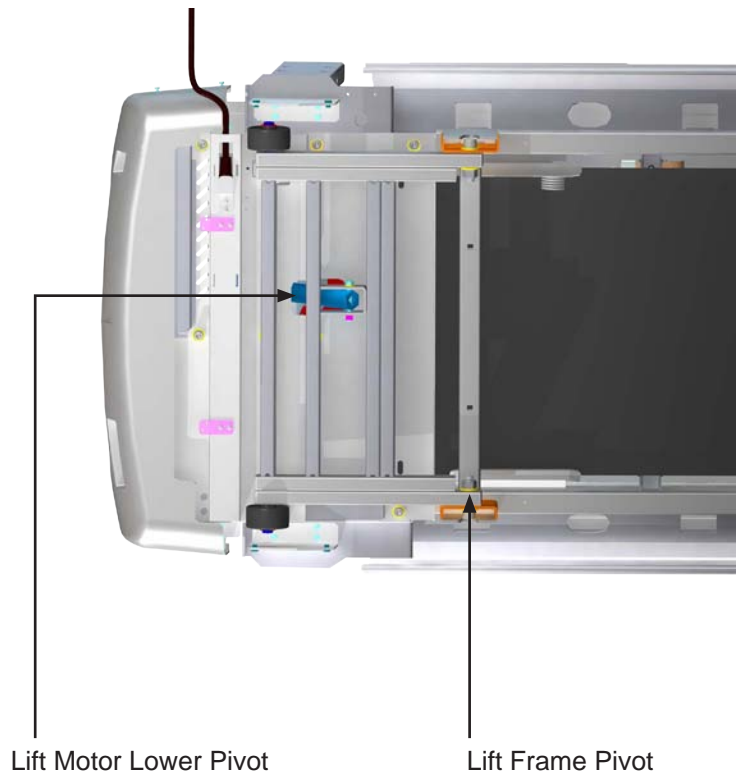

### Lift Frame for -01 and -02 Models

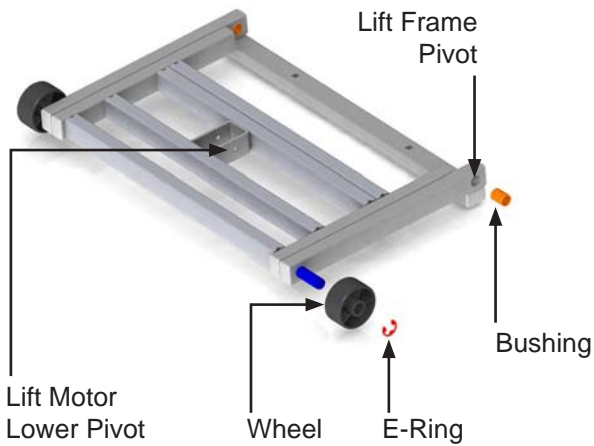

### Lift Frame for -03 and higher

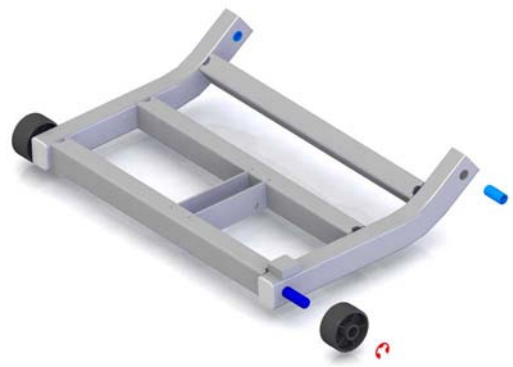

### Lift Frame Pivot for -01 and -02 Models

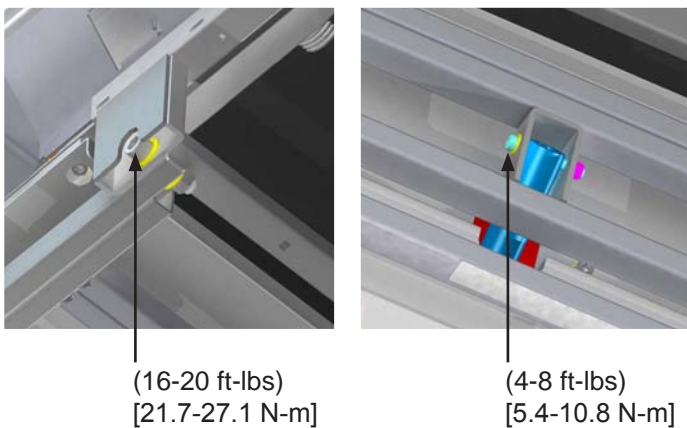

### Lift Frame Pivot for -03 and higher

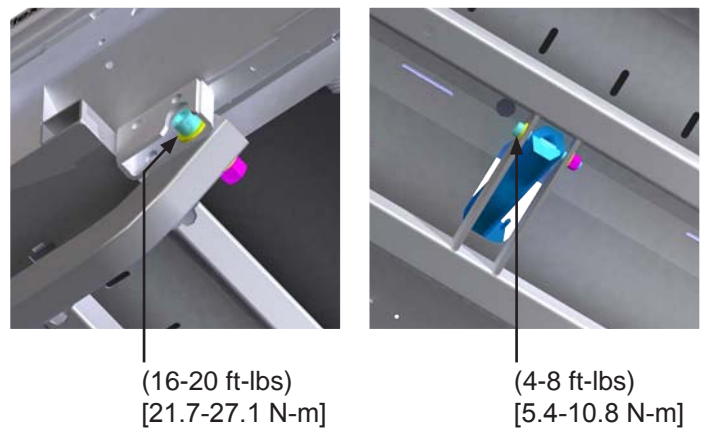



**REMOVAL OF HOME SWITCH (FOR -01 AND -02 MODELS)**

1. Operate incline and raise unit to 15 percent incline.
2. Turn the treadmill power switch off.
3. Unplug the line cord from the wall outlet.
4. Remove top motor cover.
5. Remove Frame Tie Bar.
  
6. Remove bracket with Home Switch.
7. Remove cable from Home Switch leads.
  
8. Remove Home Switch by pushing on tabs.
9. Install new Home Switch in bracket and connect cable to Home Switch leads.
10. Install Home Switch with bracket to treadmill frame
11. Install Frame Tie Bar.

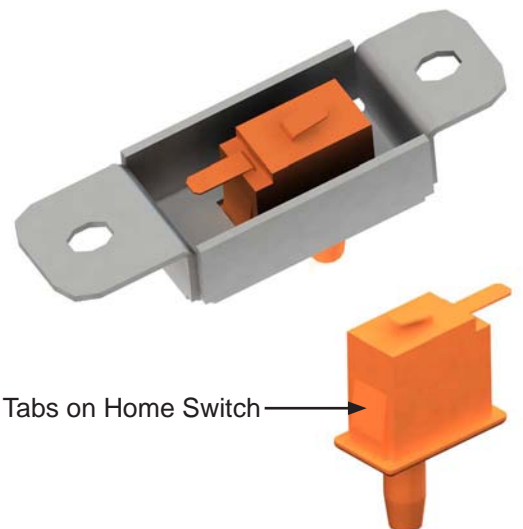
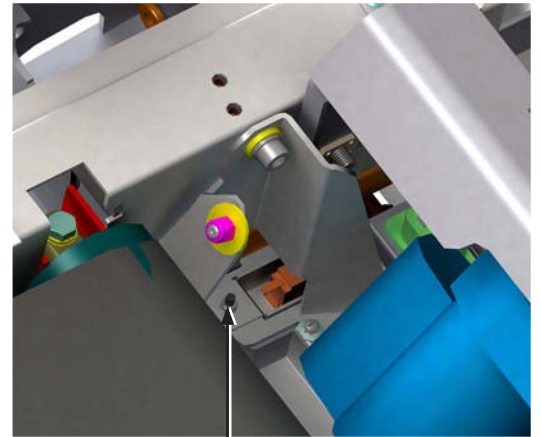
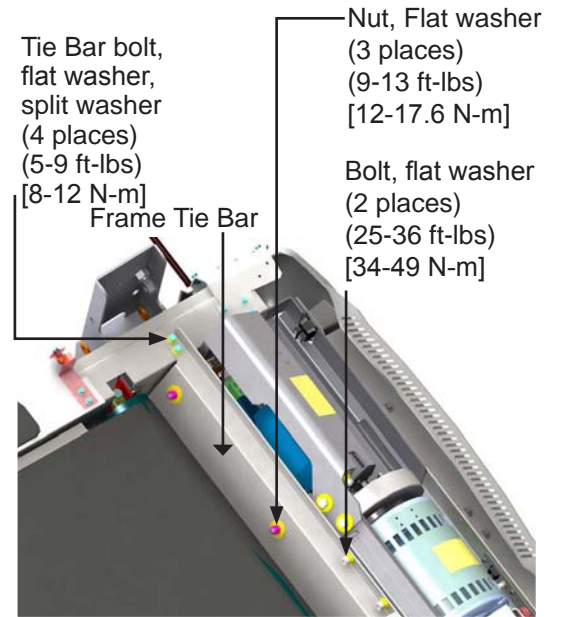

**REMOVAL OF HOME SWITCH (FOR -03 AND HIGHER)**

1. Operate incline and raise unit to 15 percent incline.
2. Turn the treadmill power switch off.
3. Unplug the line cord from the wall outlet.
4. Remove top motor cover.
5. Disconnect cable from Home Switch leads.
6. Push on Home Switch tabs and push switch down and out to remove.
7. Install new Home Switch and connect cable.

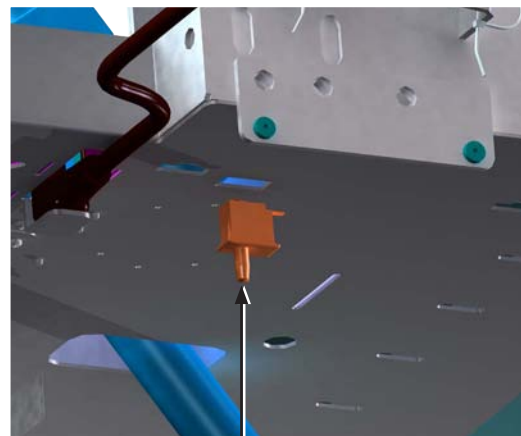

## GENERAL CONSOLE

The LCD-equipped (7- and 15-inch) elevation series consoles share a lot of the same basic functionality.

The console provides all user interface functions, user workout programs, entertainment processing, and control messages to the base. The activity zone is functionally a part of the console; the keypad and emergency stop are directly wired to the console machine interface board.

### 7- and 15-inch Differences

The 7-inch LCD (a.k.a. the i-console) and the 15-inch LCD (a.k.a. the e-console) control the machine in similar ways but have different entertainment and user interface implementations.

The “e” (15-inch LCD) depends solely on LCD touchscreen “soft buttons” for user inputs. It also includes an analog TV tuner, which has a built-in iPod Authentication Coprocessor.

The “i” (7-inch LCD) has a keypad that surrounds the screen. Since the analog tuner board is not present in the 7-inch console, iPod Authentication Coprocessor is placed on the separate board.

#### 15-inch LCD

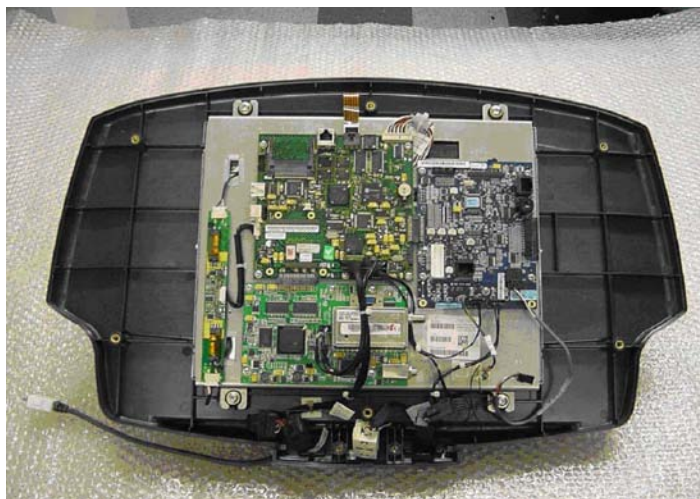

This picture shows the printed circuit boards used in the production 15-inch LCD treadmill console.

#### 7-inch LCD



This picture shows the printed circuit boards mounted in the production 7-inch LCD treadmill console.

**SBC THEORY OF OPERATION**

There are two types of the SBC. One works with the 7-inch display (SBC-i), the other one with the 15-inch display (SBC-e). Note that the two modules are not interchangeable.

The SBC-i is responsible for the following functions:

1. Communication to MIB
2. Control the 7-inch LCD & Backlight for LCD
3. Touch screen controller
4. Provide 3.3Vdc and +5Vdc for all PCBs
5. Support USB (communication with the USB, charging)
6. Support iPod® (communication with the iPod®, audio / video input, charging)
7. Receive Audio inputs (from Attachable TV, iPod®, Virtual Trainer)
8. Provide Audio output to headphones
9. Interface with Apple Authentication PCB
10. Interface with Attachable TV (receive audio, issue commands, route iPod® video to TV)

The SBC-e is responsible for the following functions:

1. Communication to MIB
2. Control the 15-inch LCD & Backlight for LCD
3. Touch screen controller
4. Generate 3.3VDC and +5VDC for all PCBs
5. Support USB (communication, charging)
6. Support iPod® (communication, audio / video input, charging)
7. Receive Audio inputs (from Tuner, iPod®, Virtual Trainer)
8. Provide Audio output to headphones
9. Interface to Analog Tuner w/ Apple Authentication
10. Generate Closed Caption
11. Implement hardware for Ethernet connectivity (future functionality, not supported by software)

**MIB THEORY OF OPERATION**

There is only one kind of the MIB. It works with both the 7- and the 15-inch displays.

The functions of the MIB include:

1. Process LifePulse® (LP) Heart Rate signal from sensors
2. Receive Telemetry (Polar) Heart Rate signal
3. Calculate Heart Rate (LP & Polar)
4. Interface to membrane switch keypad
5. Respond to Emergency Stop Switch
6. Redundant CSAFE ports (for Serial Comm or accessory power)
7. Serial Comm (+5VDC) to GBC / MC
8. Serial Comm (+3.3VDC) to SBC
9. Provide Battery Voltage / switch for Normal Operation
10. Provide Battery Voltage / switch for Sleep Mode
11. Drive speaker (monotone beep)
12. Low side drive for all LEDs
13. Drive the LEDs of the Data Display and Keypad
14. Generate IR commands for attachable TV

**DATA DISPLAY THEORY OF OPERATION (USED ON THE 7-INCH LCD ONLY)**

Provides 7-segment displays to create 3 data fields of 4, 3, 4 numerals. Drives all LEDs.

**ANALOG TUNER THEORY OF OPERATION**

The functions provided by the tuner are: Right angle adapter to convert F-connector to RCA,

Receive NTSC or PAL/SECAM Analog video via RCA input

Implement NTSC or PAL/SECAM Tuner,

Provide Audio and Video outputs to SBC-e,

Implement I2C for Apple Authentication co-processor

**APPLE AUTHENTICATION THEORY OF OPERATION**

This board allows for positive authentication of Apple devices like iPod® and iPhone® (collectively known as an i-product) in order to access audio and video play lists.

This functionality is implement via an I2C communication between the i-product, the SBC, and the authentication co-processor.

**HEADPHONE ESD PRINTED CIRCUIT BOARD**

This board protects the Single Board Computer (SBC) board from Electrostatic Discharges (ESD) that may reach the SBC via the headphone jack.

**LIFEPULSE ESD PRINTED CIRCUIT BOARD**

This board protects the Machine Interface Board (MIB) from Electrostatic Discharge (ESD) that may reach the board via LifePulse sensor inputs.

**CODED RECEIVER**

This board receives Telemetry Heart Rate pulses from chest strap. This board implements variable gain control to ensure coded operation with the intended transmitter.

**BACKLIGHT INVERTER (7-INCH LCD)**

This board converts 12VDCto more than 500 VAC for the back light known as the Cold Cathode Flourescent Light (CCFL) light.

**BACKLIGHT INVERTER (15-INCH LCD)**

This board converts 12VDC to more than 500 Vac for the back light known as the Cold Cathode Flourescent Light (CCFL) light.



# Console & Activity Zone: System Components

M051-00K65-A003

## 15-INCH LCD CONSOLE SYSTEM COMPONENT

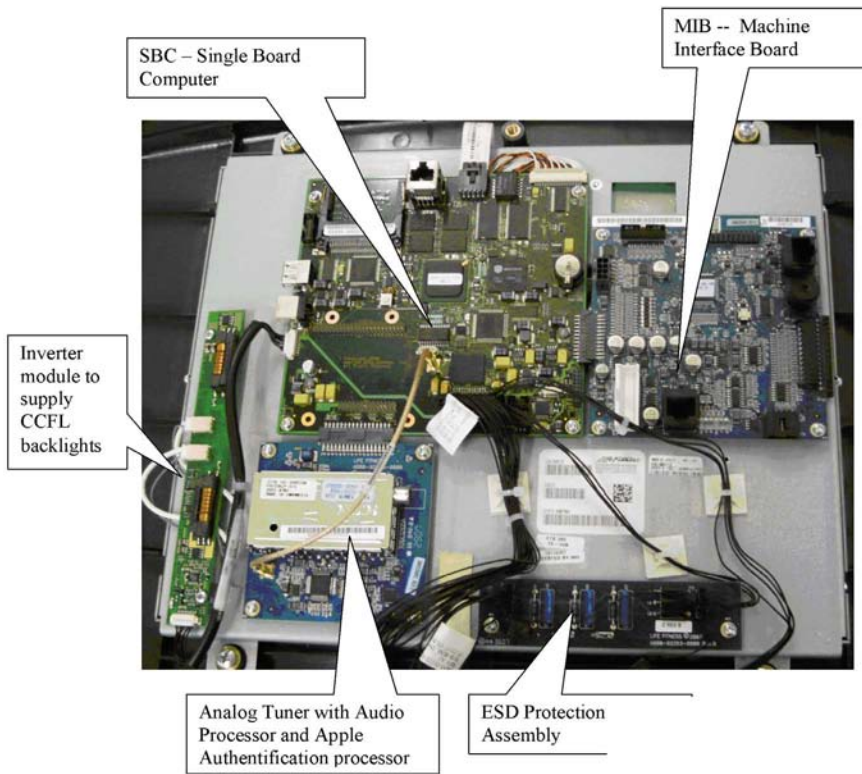

## 7-INCH LCD CONSOLE SYSTEM COMPONENT

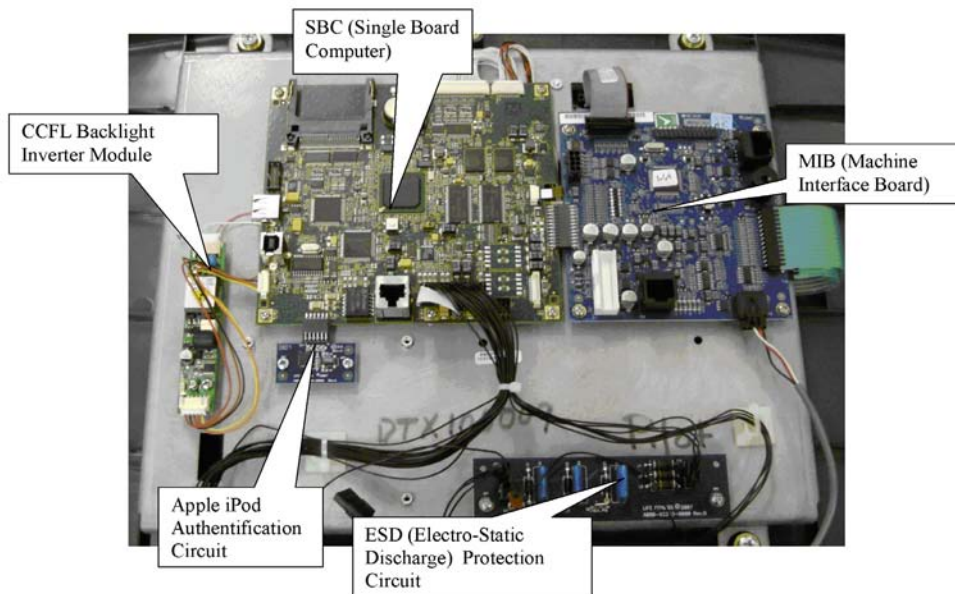



## ACTIVITY ZONE

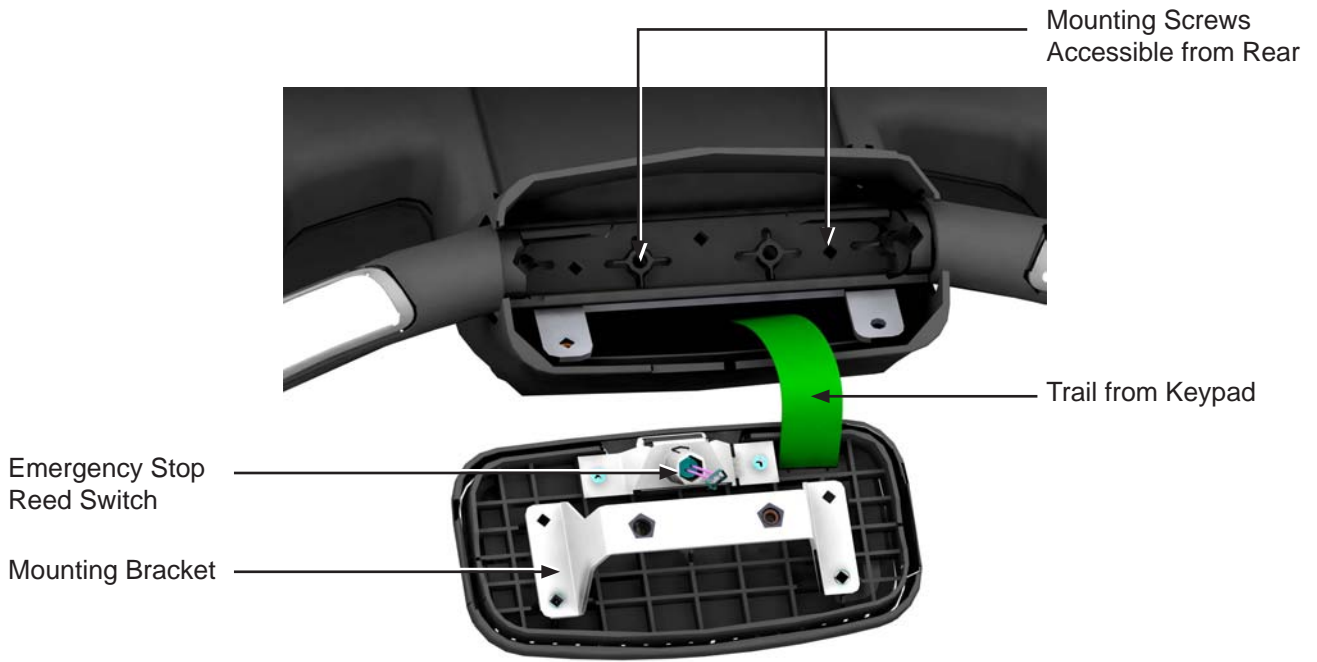

## POLAR TELEMETRY BOARD

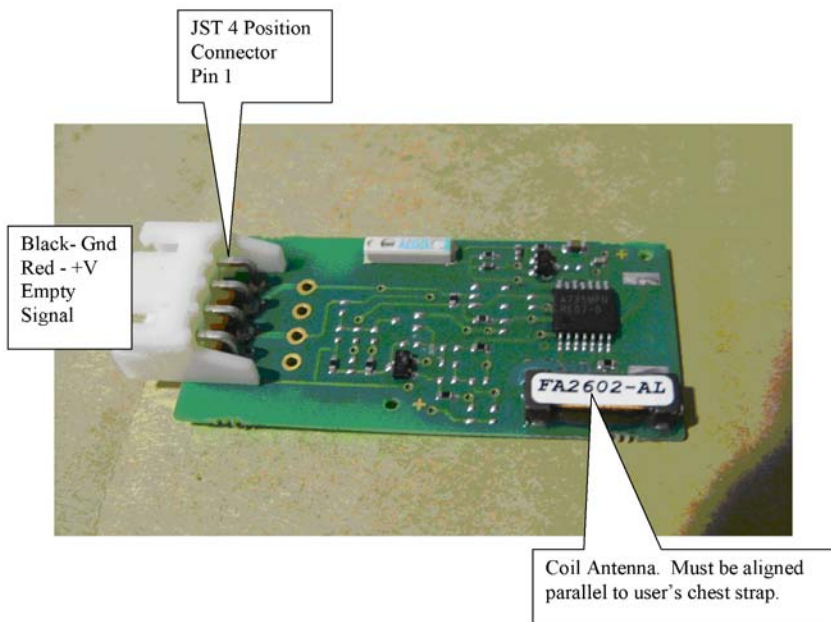

**Console & Activity Zone: Problem Symptom Table**

M051-00K65-A003

**CONSOLE**

SYMPTOM	POSSIBLE CAUSE	SECTION	PAGE
No power to console	No power to base	Check that there is power at the outlet, breaker and switch all OK.	
	Faulty main cable or bad cable connection	Check +12VDC at Pins 11 and 12 of main cable that goes to MIB. Replace cable if necessary.	
No audio, screen does not turn on	Faulty main cable	Check for power to console.	
	Defective SBC	Replace SBC.	
	Defective LCD screen	Replace LCD panel.	
No backlight, screen is dark	Defective inverter	Test inverter – replace if necessary.	
	Defective SBC	Replace SBC.	
	Defective backlights	Replace LCD panel.	
Touchscreen not accurate	Touchscreen needs calibration	Calibrate touchscreen.	
	Defective LCD touchscreen	Replace the touchscreen.	
Touchscreen does not respond	Defective LCD touchscreen	Replace the touchscreen.	
	Safety key not seated properly	Reseat safety key.	
Snow and noise appear on screen	Air / cable setting incorrect	Change setup to proper setting.	
	Defective coax – no signal	Verify signal present.	
	Defective tuner board	Replace tuner board.	
Unable to receive cable channels	Air / cable setting incorrect	Change setup to proper setting.	
	Defective coax – no signal defective	Verify signal present.	
Channels do not change	Touchscreen needs calibration	Calibrate touchscreen.	
	Defective LCD touchscreen	Replace touchscreen.	
	Defective SBC	Replace SBC.	
	Defective MIB	Replace MIB.	
	Defective analog tuner	Replace tuner.	

**Console & Activity Zone: Problem Symptom Table**

M051-00K65-A003

**CONSOLE**

SYMPTOM	POSSIBLE CAUSE	SECTION	PAGE
Sound does not change	Touchscreen needs calibration	Calibrate touchscreen	
	Defective MIB	Replace MIB	
No sound	Air/Cable setting incorrect	Change setup to proper setting	
	Defective headphones	Try different headphones	
	Defective headphone jack or cable	Inspect and replace as appropriate.	
iPod does not work.	Defective iPod® cable on option panel	Replace option panel	
	Defective iPod®	Verify iPod® function	
	Defective tuner board – Authentication fails.	Replace tuner board	
Ghost HR – on engage treads power cable routing, or receiver too sensitive, happened with early production non-coded.	Non updated cable being used, frame not properly grounded, early non-coded receiver installed.	Cable should be AK65-00043-0001 A2 or later. See service Bulletin on frame grounding. Install coded receiver.	
Emergency stop not working	MIB defective, magnet misplaced in holder	Check that the magnet is properly located in the plastic holder. Replace MIB if cable and magnet good.	
Video lockup	Old revision of tuner and / or SBC	Try tuner revision F or later, if still bad then try SBC revision E or later.	
Distorted audio	Option panel not updated	Install latest revision option panel.	
Headphone jack loose	Option panel not updated	Install latest option panel.	
iPod® not charging	Defective iPod® cable or connection from option panel to MIB, option panel not updated	Check cable and connections, replace, repair as appropriate. Install latest revision option panel.	
Console does not recognize USB memory drive inserted into connector.	Defective USB drive or connector / cable / connection	Verify functionality of USB drive. Check cable and connections, replace, repair as appropriate.	

**Console & Activity Zone: Problem Symptom Table**

M051-00K65-A003

**ACTIVITY ZONE**

<b>SYMPTOM</b>	<b>POSSIBLE CAUSE</b>	<b>SECTION</b>	<b>PAGE</b>
Buttons not registering	Damage	Check connections.	<a href="#">CA 22</a>
	Not Connected	Replace Activity Zone.	
Need to replace Activity Zone.	Damage	Replace Activity Zone.	<a href="#">CA 22</a>
	Cosmetic flaws		
Need to replace console neck spacer.	Damage	Replace console neck spacer.	<a href="#">CA 23</a>
	Cosmetic flaws		
Console inoperative	Misconnection	Replace console.	<a href="#">CA 23</a>
	Damaged		
Rear console cover requires replacement.	Damage	Replace console cover.	<a href="#">CA 24</a>
	Cosmetic Flaws		

**NO POWER**

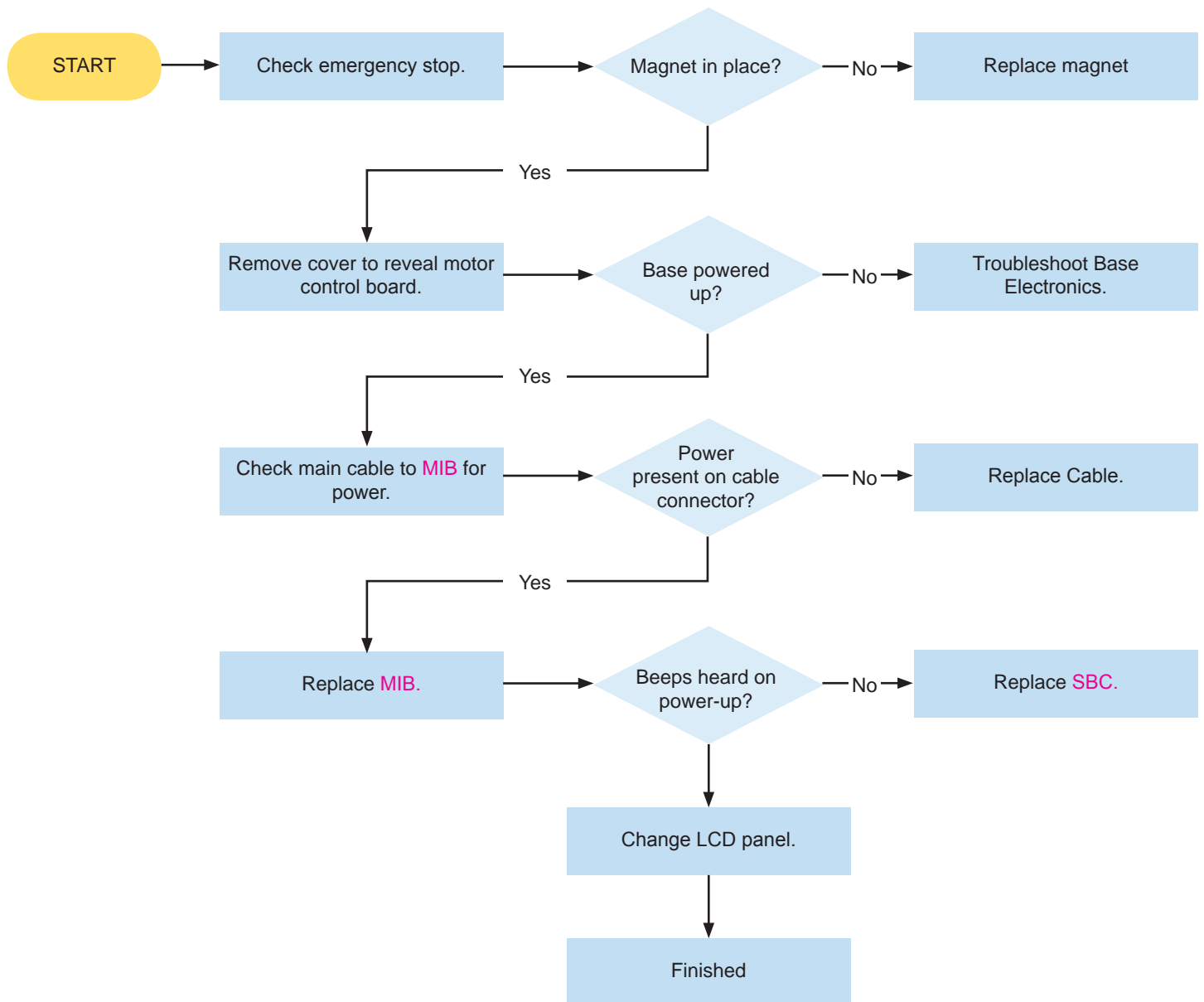

TV NOT WORKING

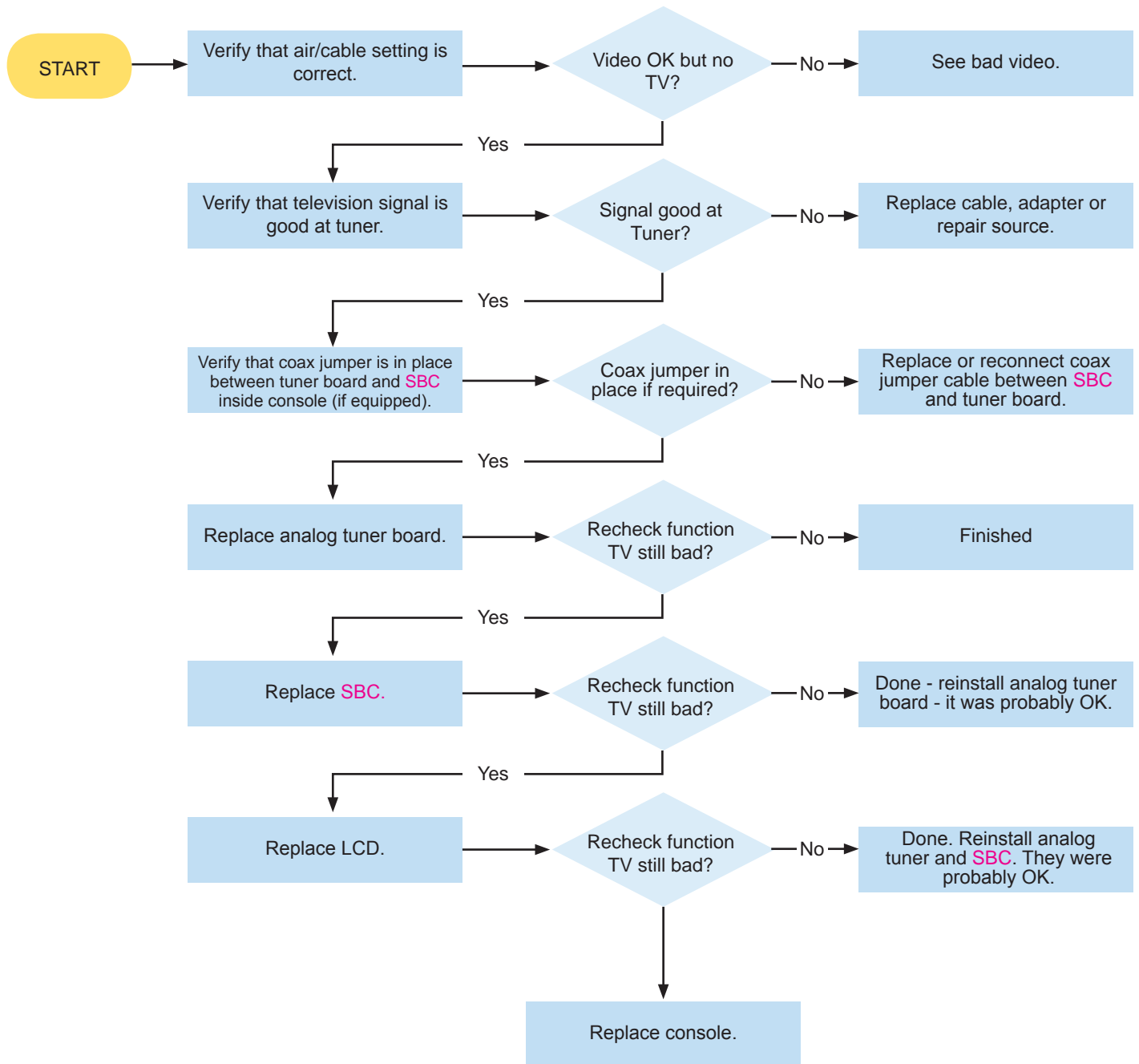

**NO VIDEO ON LCD**

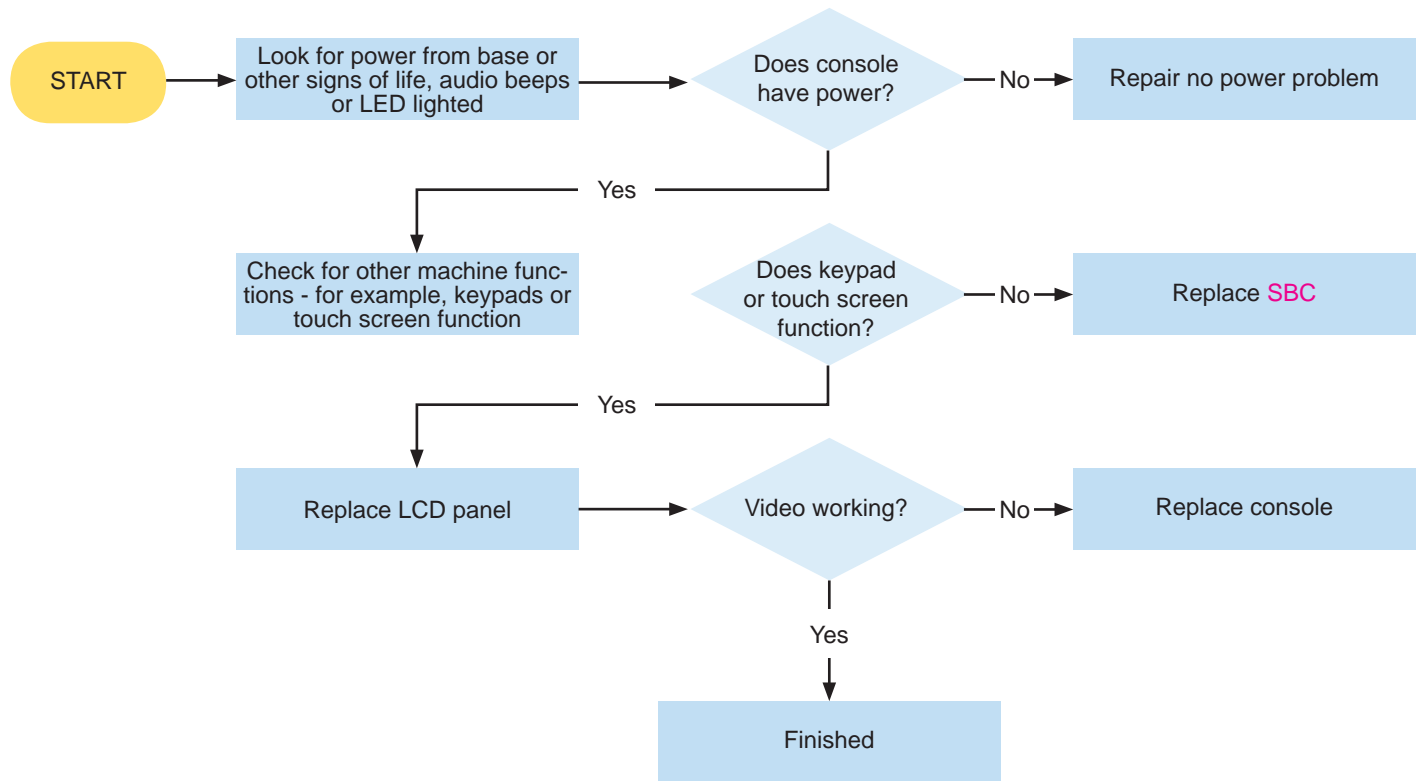

**DISTORTION / NOISE IN AUDIO**

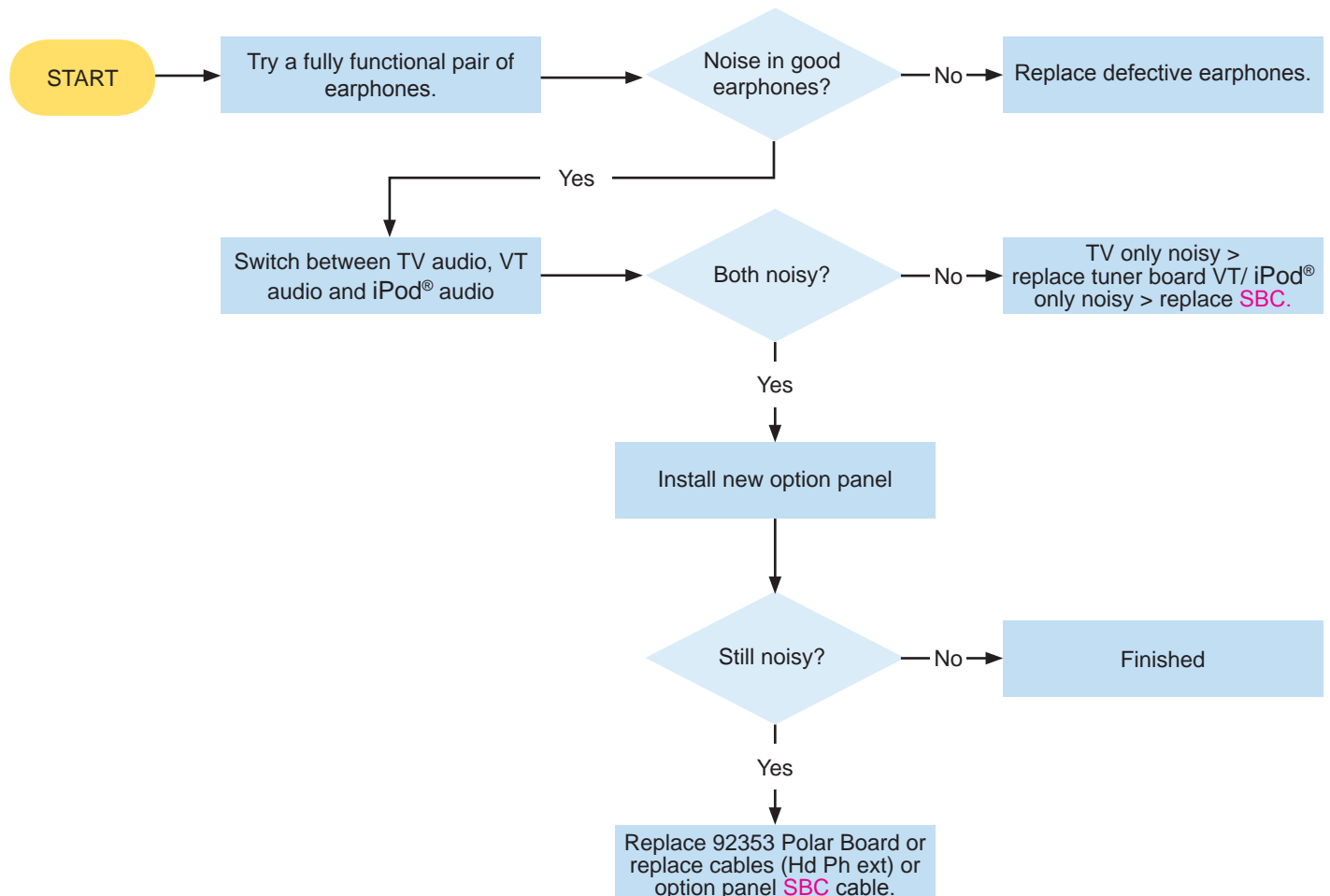

TELEMETRY HR NOT WORKING

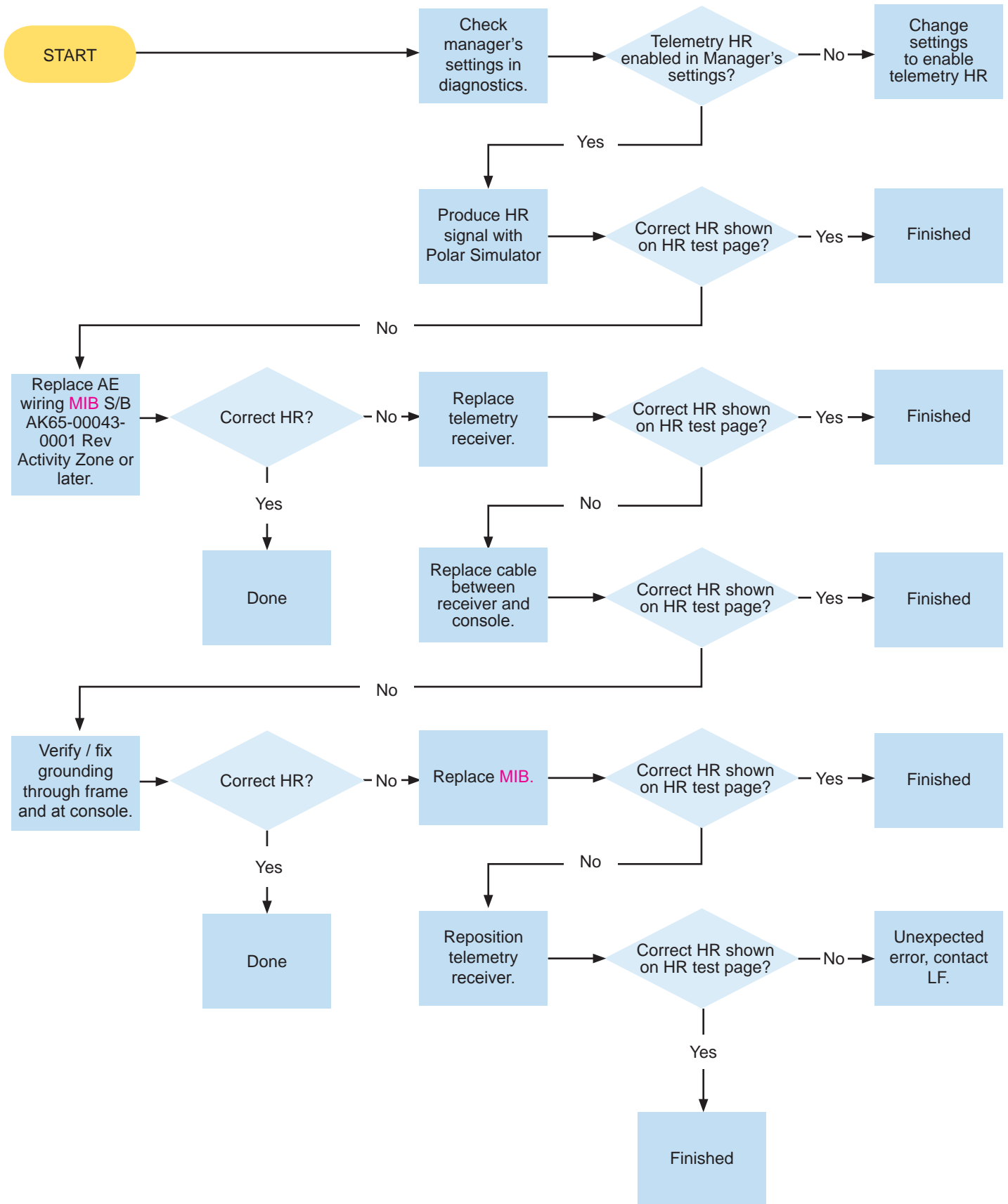



KEYPAD NOT RESPONDING

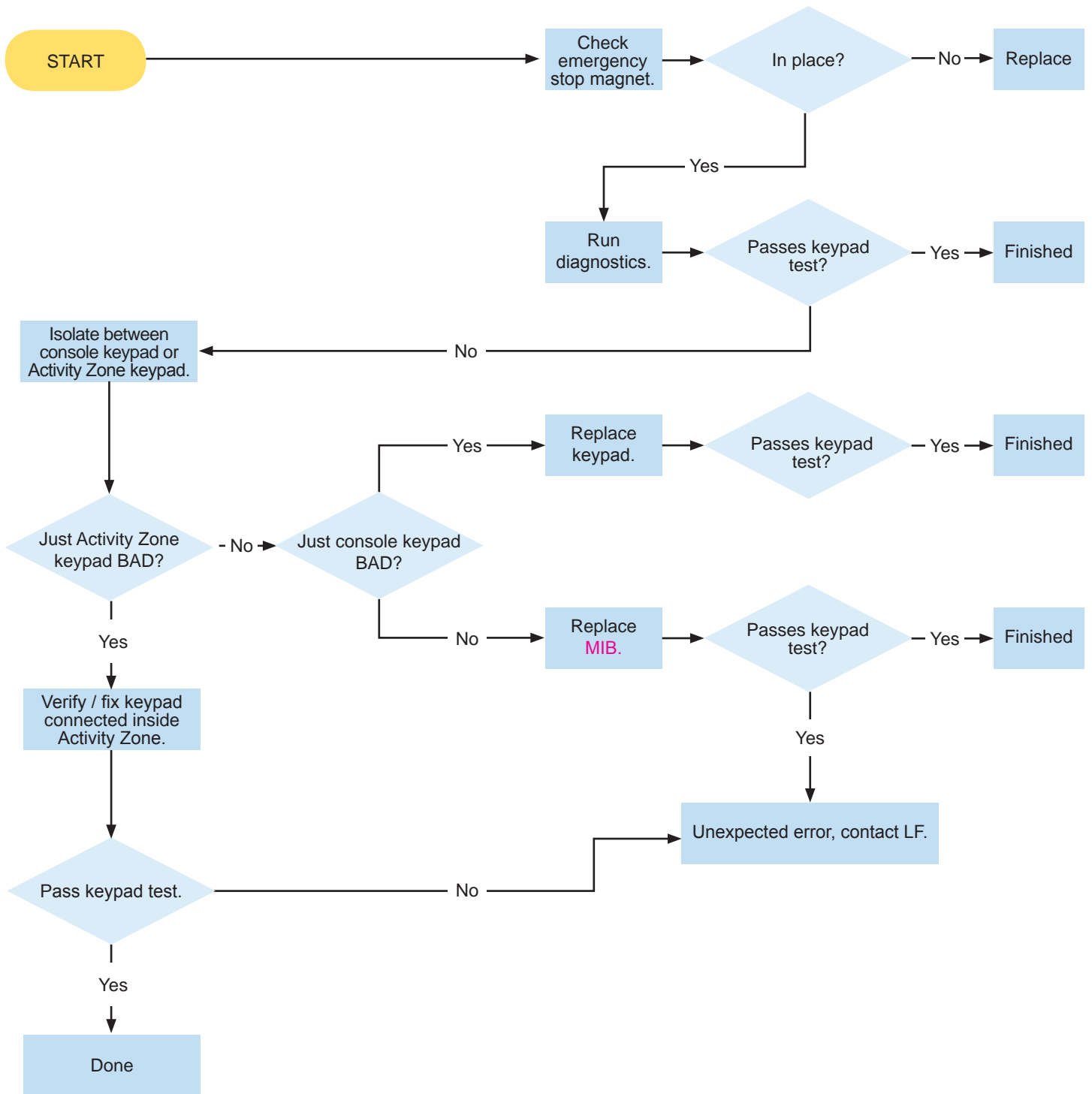

**TIP:** All hard keys (keypads) are connected to and processed by the MIB board. Anytime a key is pressed the MIB will issue a confirmation 'beep' unless the Club has turned Off 'System Sounds' in Manager's Configuration.

LIFEPULSE® HR NOT WORKING

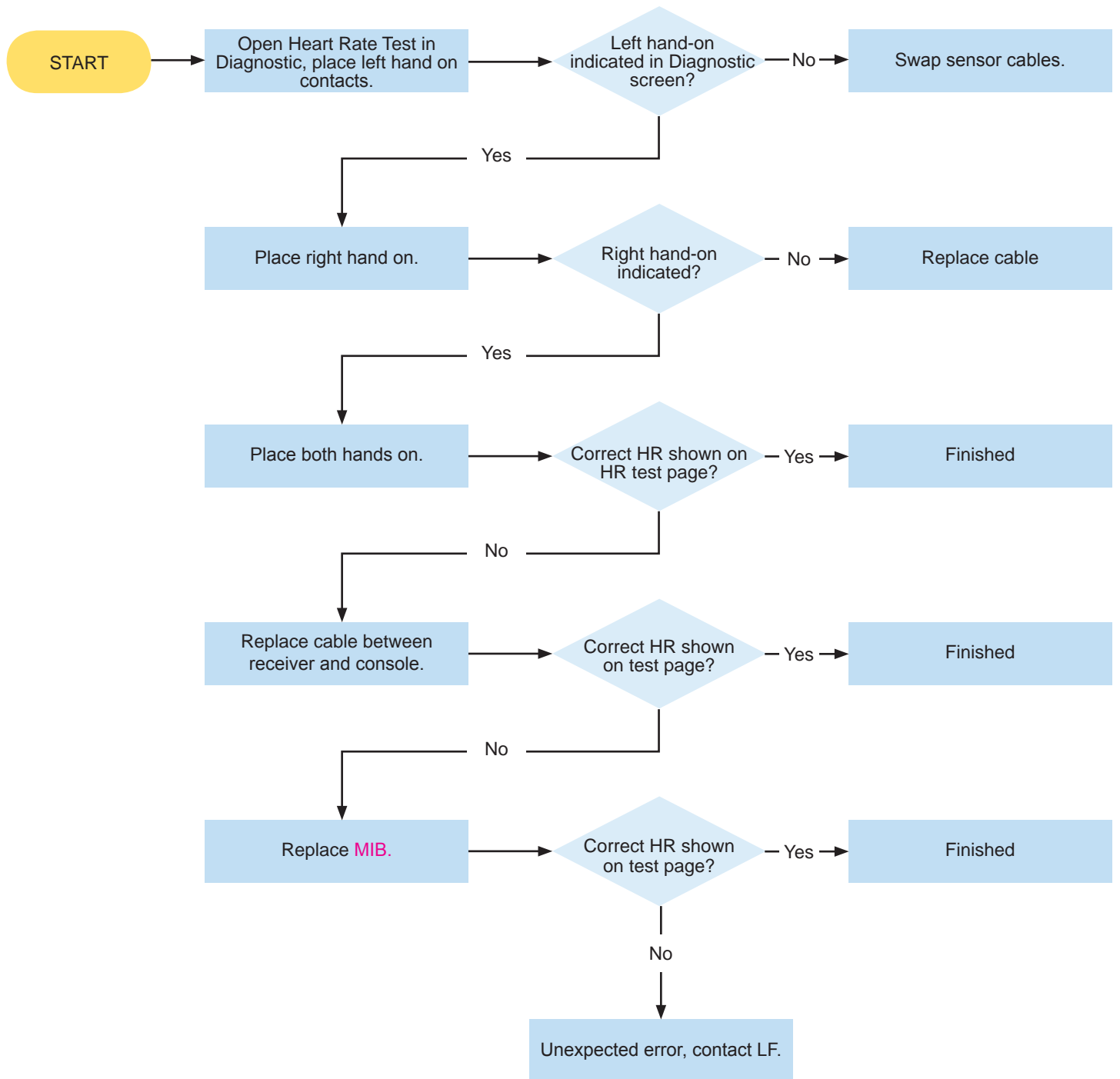

LCD SCREEN IMAGES ARE DIM/DARK

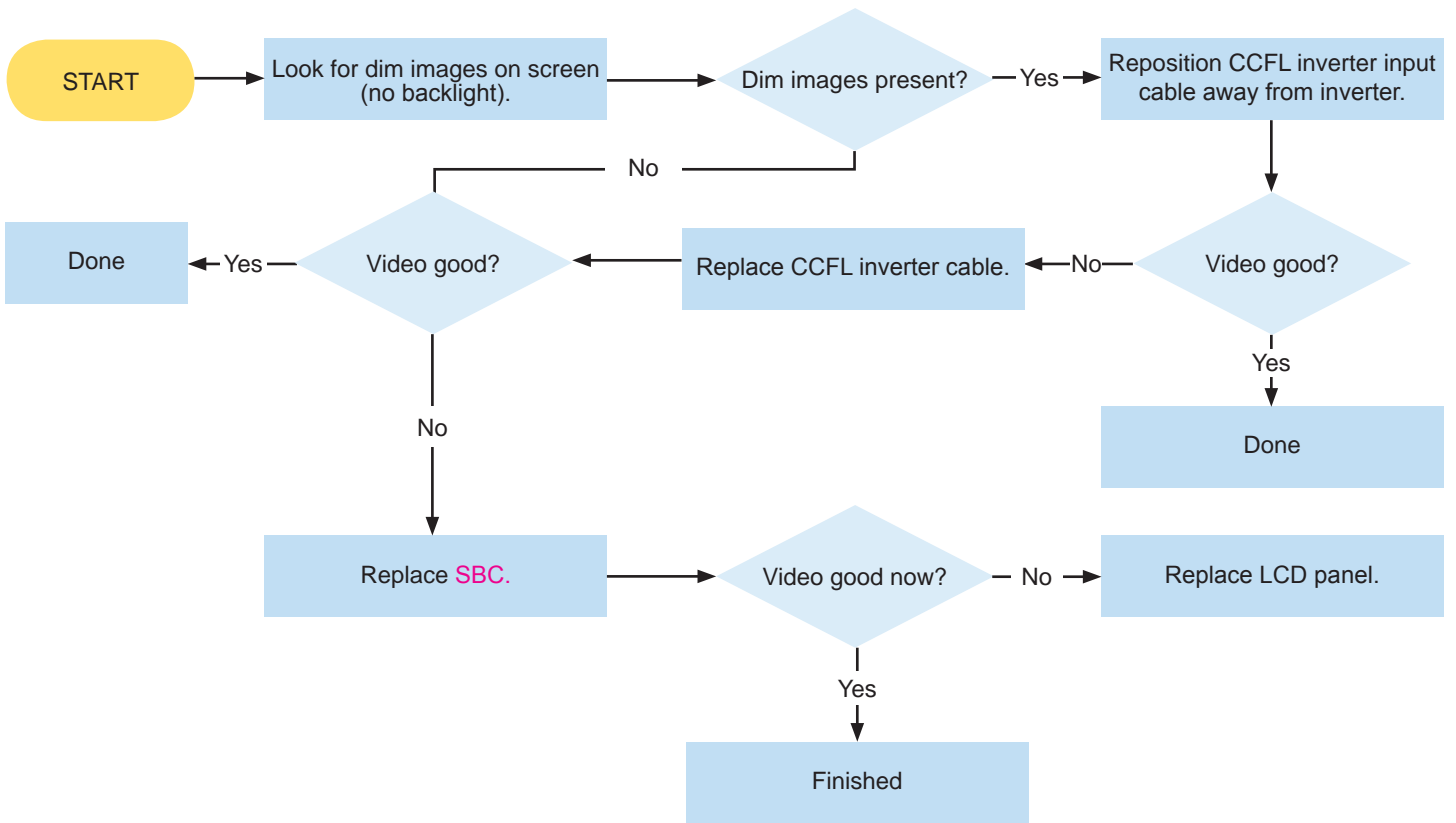

iPod® DOES NOT WORK

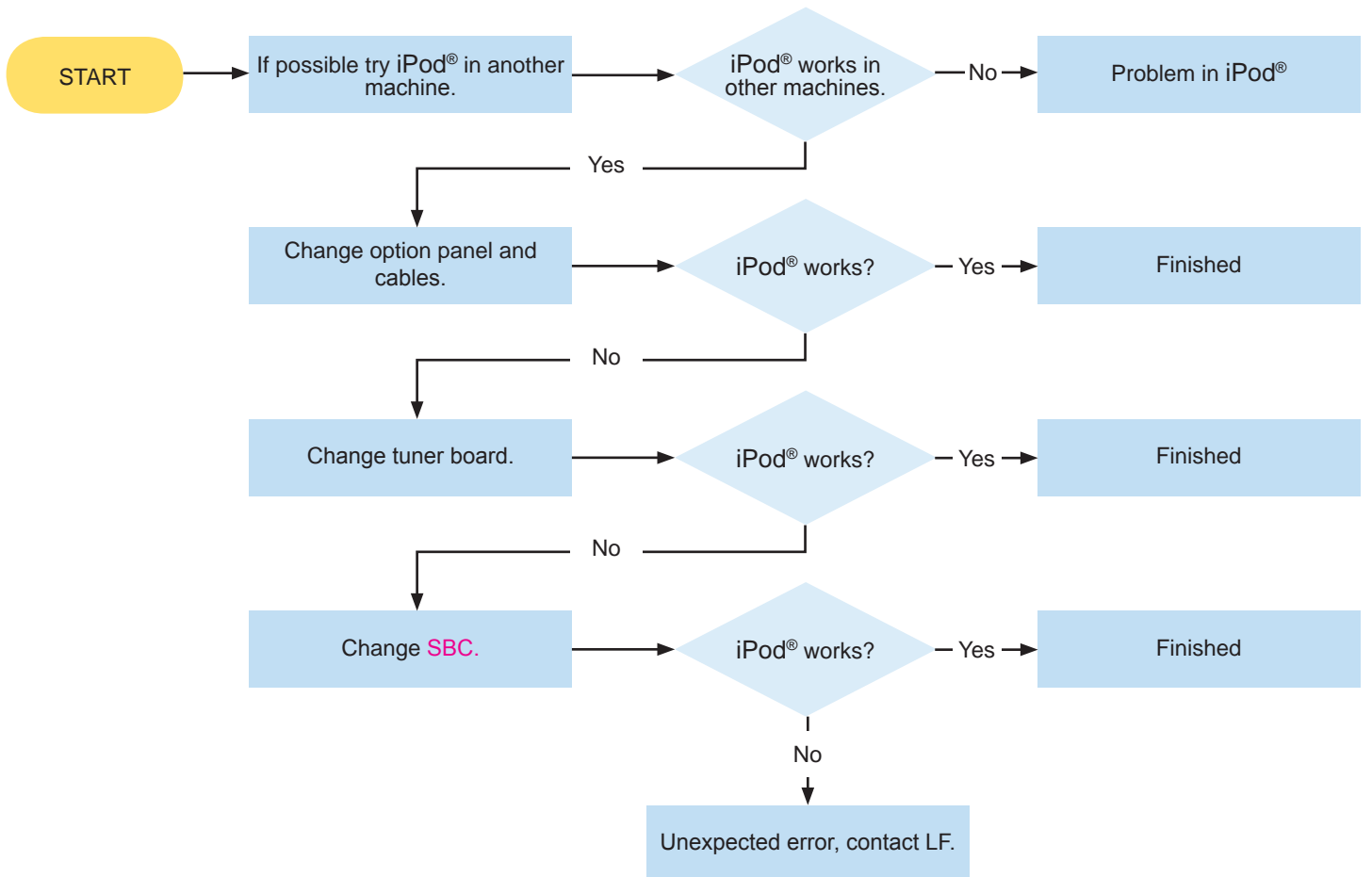

**TOUCH SCREEN NOT RESPONDING**

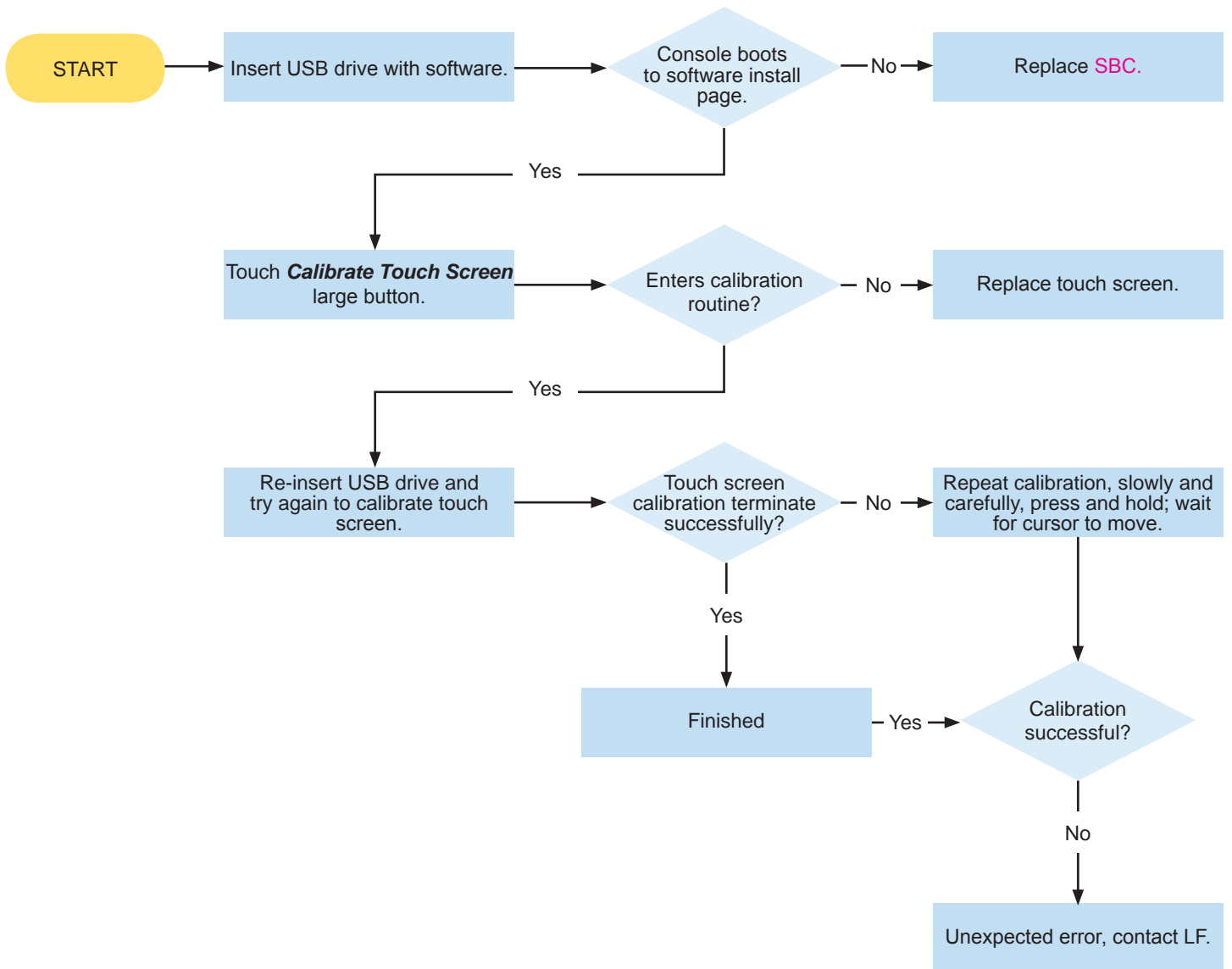

**CHANNELS DO NOT CHANGE**

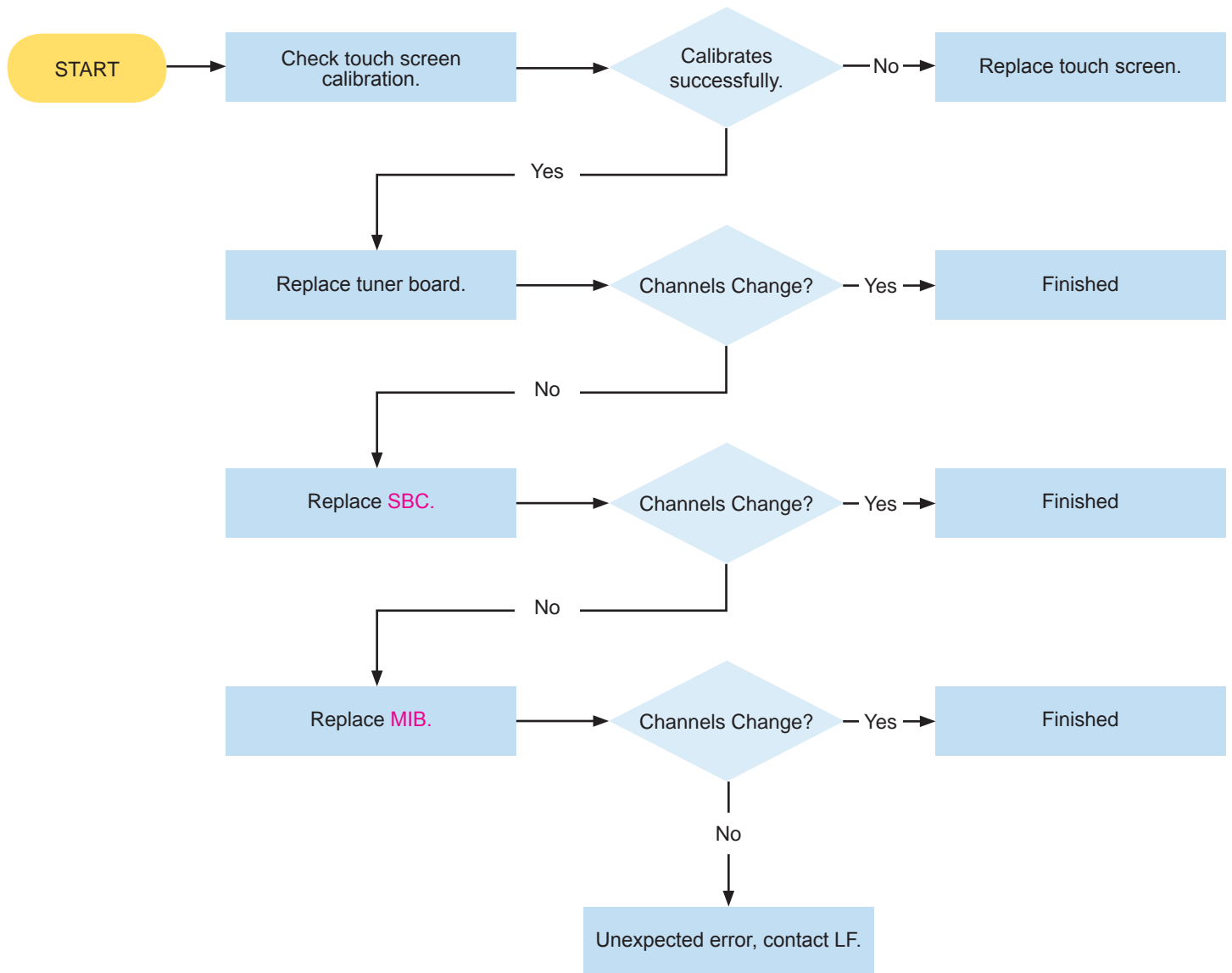

**AUDIO DOES NOT CHANGE**

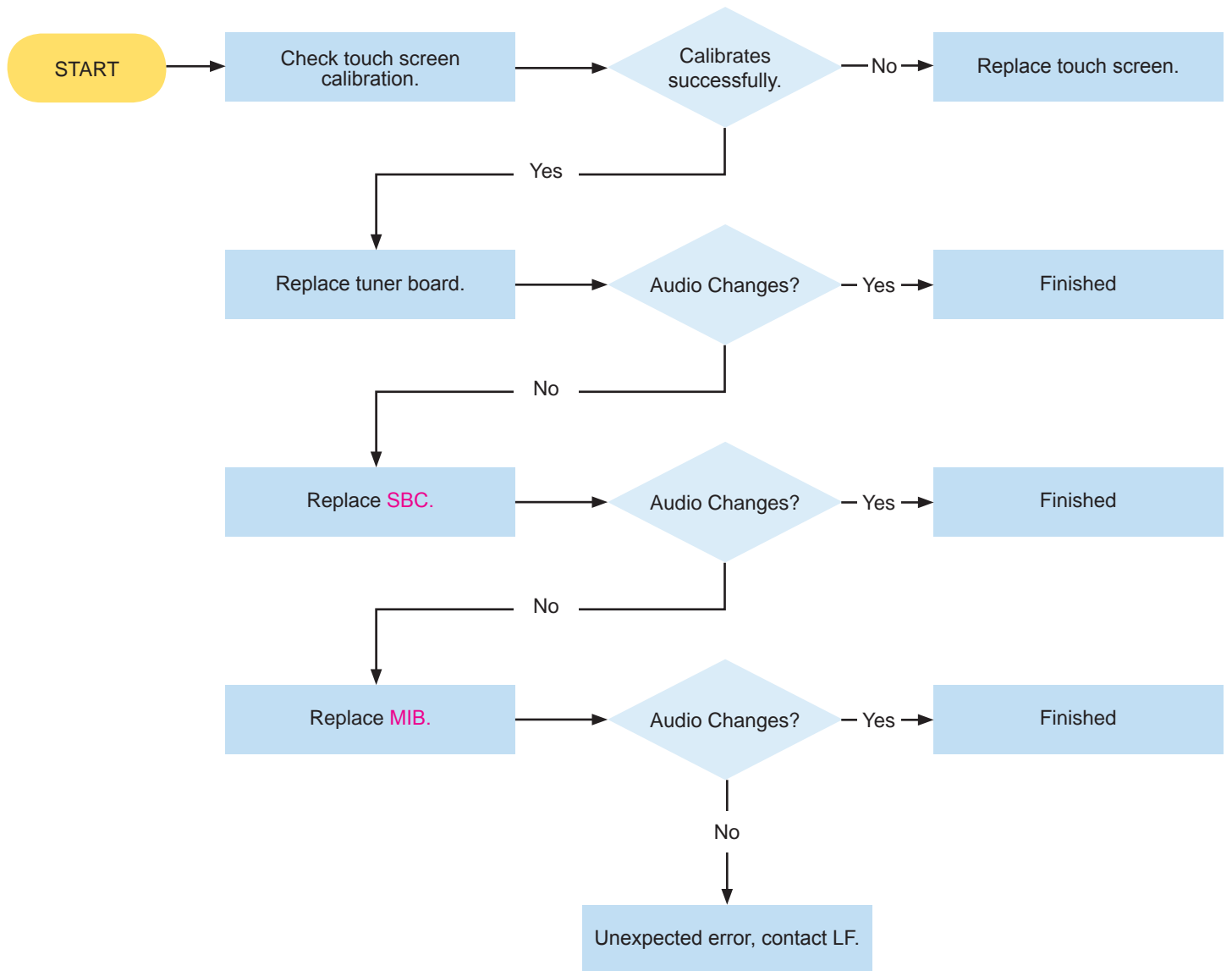

**USB DRIVE NOT RECOGNIZED**

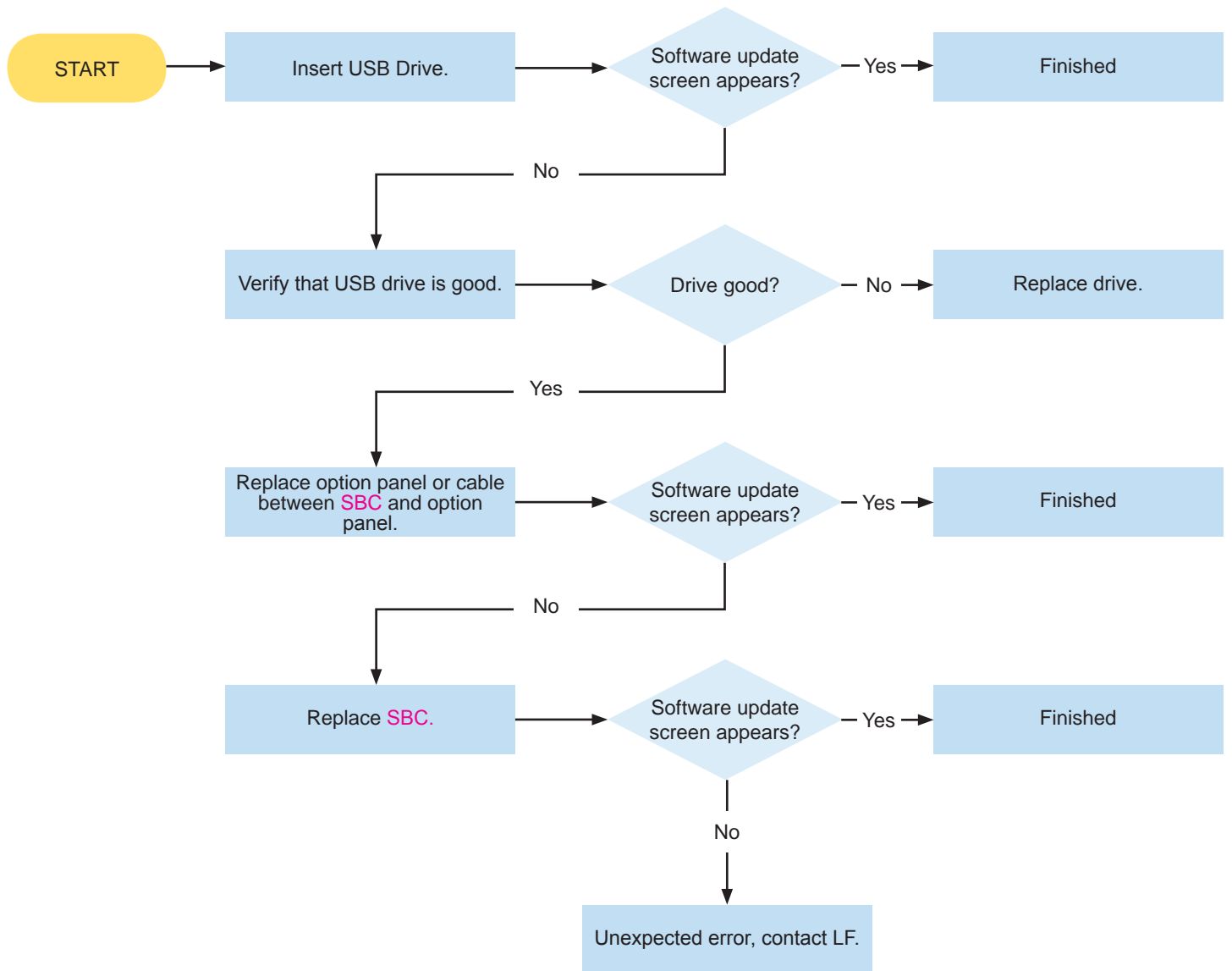

## Console & Activity Zone: How To's

M051-00K65-A003

### REPLACEMENT OF ACTIVITY ZONE

1. Turn the treadmill power switch off.
2. Unplug the line cord from the wall outlet.
3. Remove the bezel access located on the bottom of the lower bridge cover.

4. Remove and save the two bolts that secure the Activity Zone assembly to the bridge weldment. Use a flashlight to locate the bolts.

5. Disconnect the cable connections to the Activity Zone.
6. Remove the Activity Zone assembly.
7. Install the new Activity Zone assembly, using the bolts and saved in Step 4.

Bezel Access Door



Screws





**REPLACEMENT OF CONSOLE NECK SPACER**

1. Turn the treadmill power switch off.
2. Unplug the line cord from the wall outlet.
3. Remove the rear console cover.
4. Remove the console assembly.
5. Remove and save the two Allen bolt heads that secure the console neck spacer to the console mounting bracket.
6. Remove the console neck spacer.
7. Install the new console neck spacer using the bolts saved in Step 5.

Neck Spacer  
Screws (2)

Torque to  
25-35 in\*lb.  
[29-40 kg\*cm]

Console Bracket

Console  
Neck Spacer



**REPLACEMENT OF THE CONSOLE ASSEMBLY**

1. Turn the treadmill power switch off.
2. Unplug the line cord from the wall outlet.
3. Remove the rear console cover.
4. Remove and save the four Phillips screws that secure the console assembly to the console mounting bracket.
5. Disconnect all cables to the console assembly.
6. Install the new console assembly using the screws saved in Step 4.

Console

Console Bracket

Console Mounting  
Screws (4)

Rear Console  
Cover



Rear Console  
Cover  
Screws (2)

Torque to  
25-35 in\*lb.  
[29-40 kg\*cm]

**REPLACEMENT OF REAR CONSOLE COVER**

1. Remove and save the two Allen screws that secure the rear console cover to the console mounting bracket.
2. Remove the rear console cover.
3. Install the new rear console cover using the screws saved in Step 1.

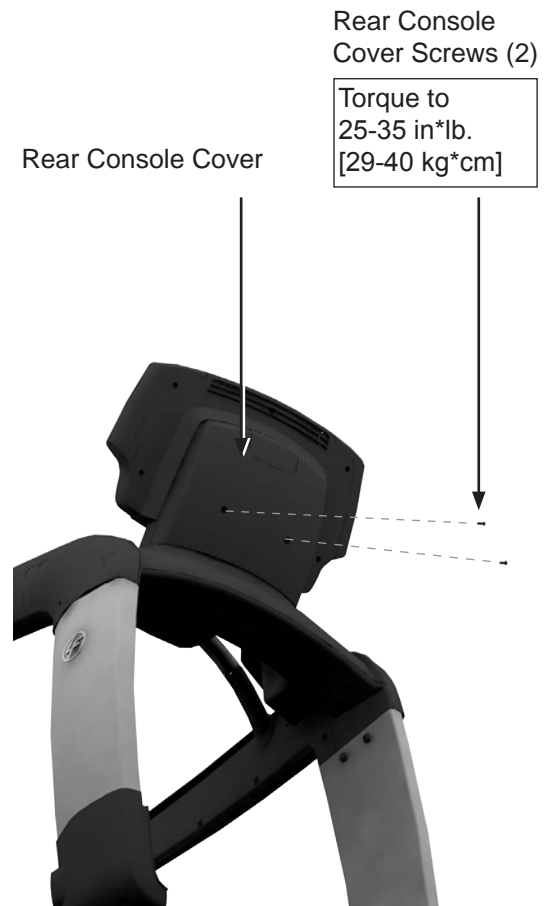
**REPLACEMENT OF OPTION PANEL**

1. Using a #1 Phillips screw driver, remove the two screws that secure the option panel. Save these screws.
2. Gently pull connector through Front Plastics.
3. Disconnect the headphone, USB and iPod® connections.
4. Install new option panel and verify all connections.

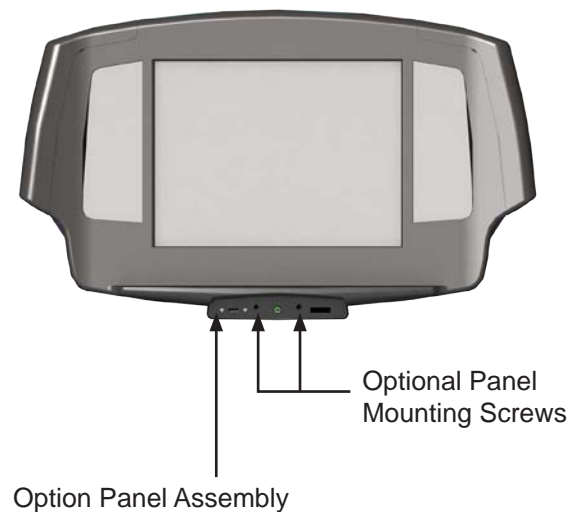

# Console & Activity Zone: Electrical Wiring Diagrams

M051-00K65-A003

## BLOCK DIAGRAM - 15 INCH CONSOLE

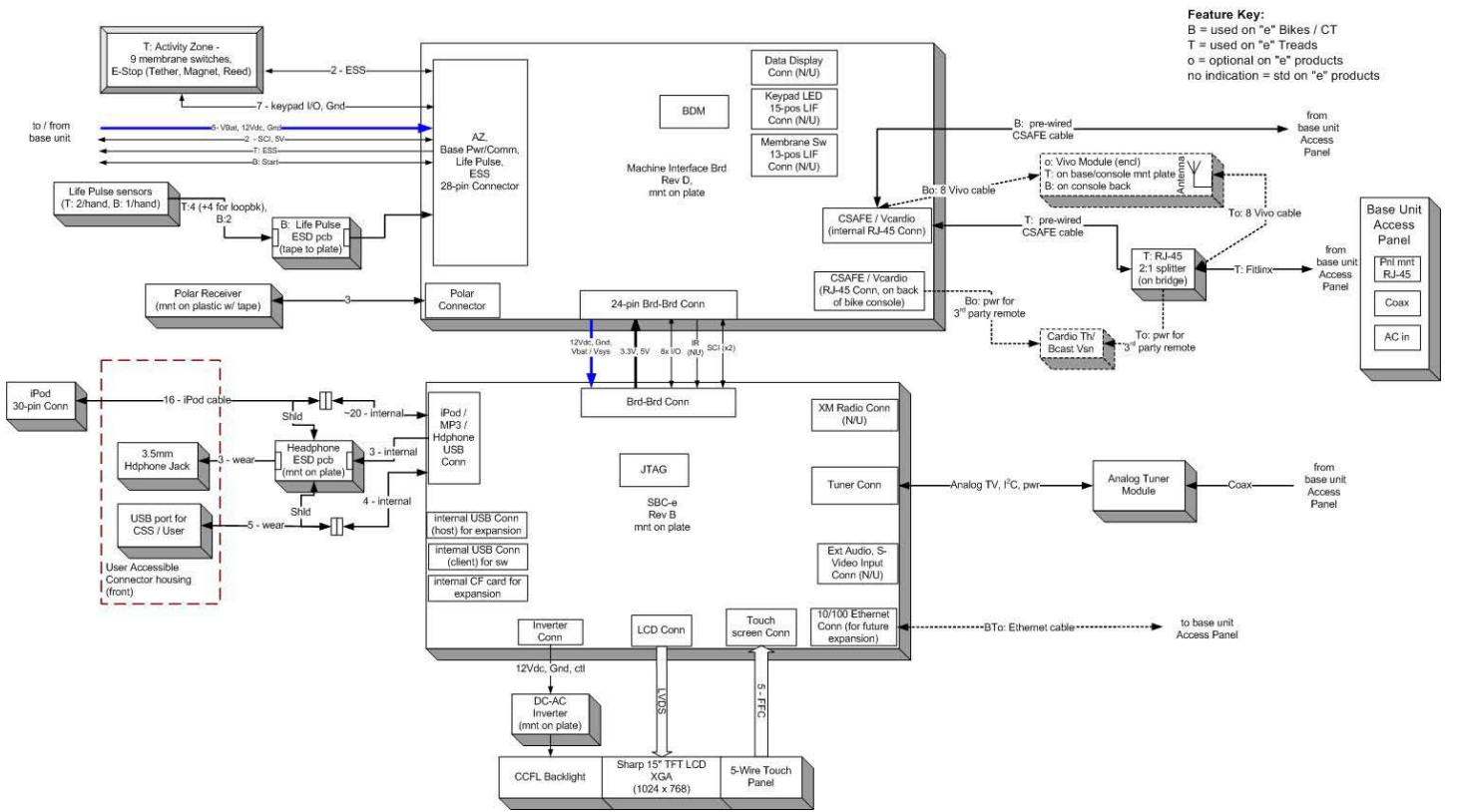

## BLOCK DIAGRAM - 7 INCH CONSOLE

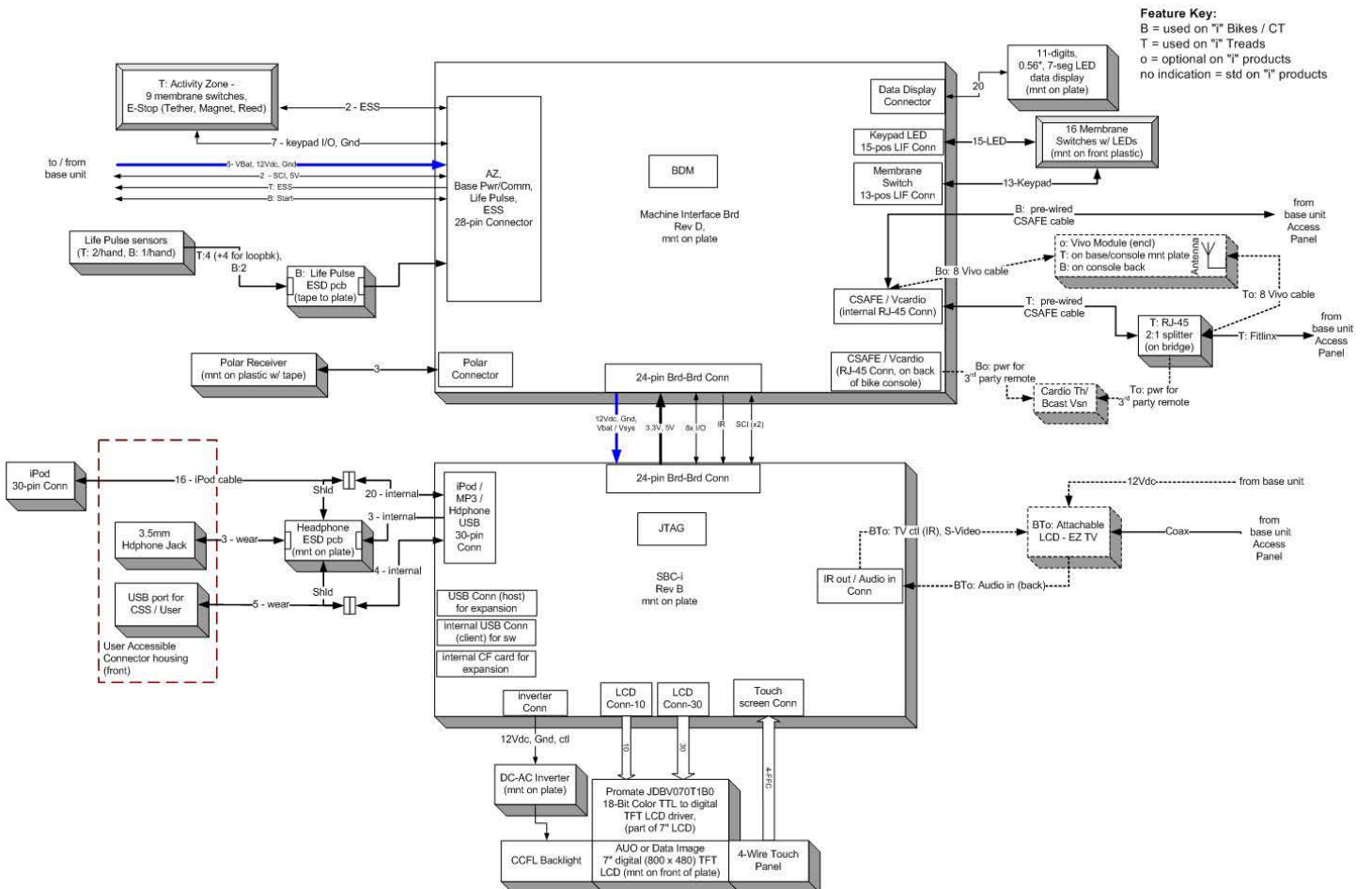

# Console & Activity Zone: Electrical Wiring Diagrams

M051-00K65-A003

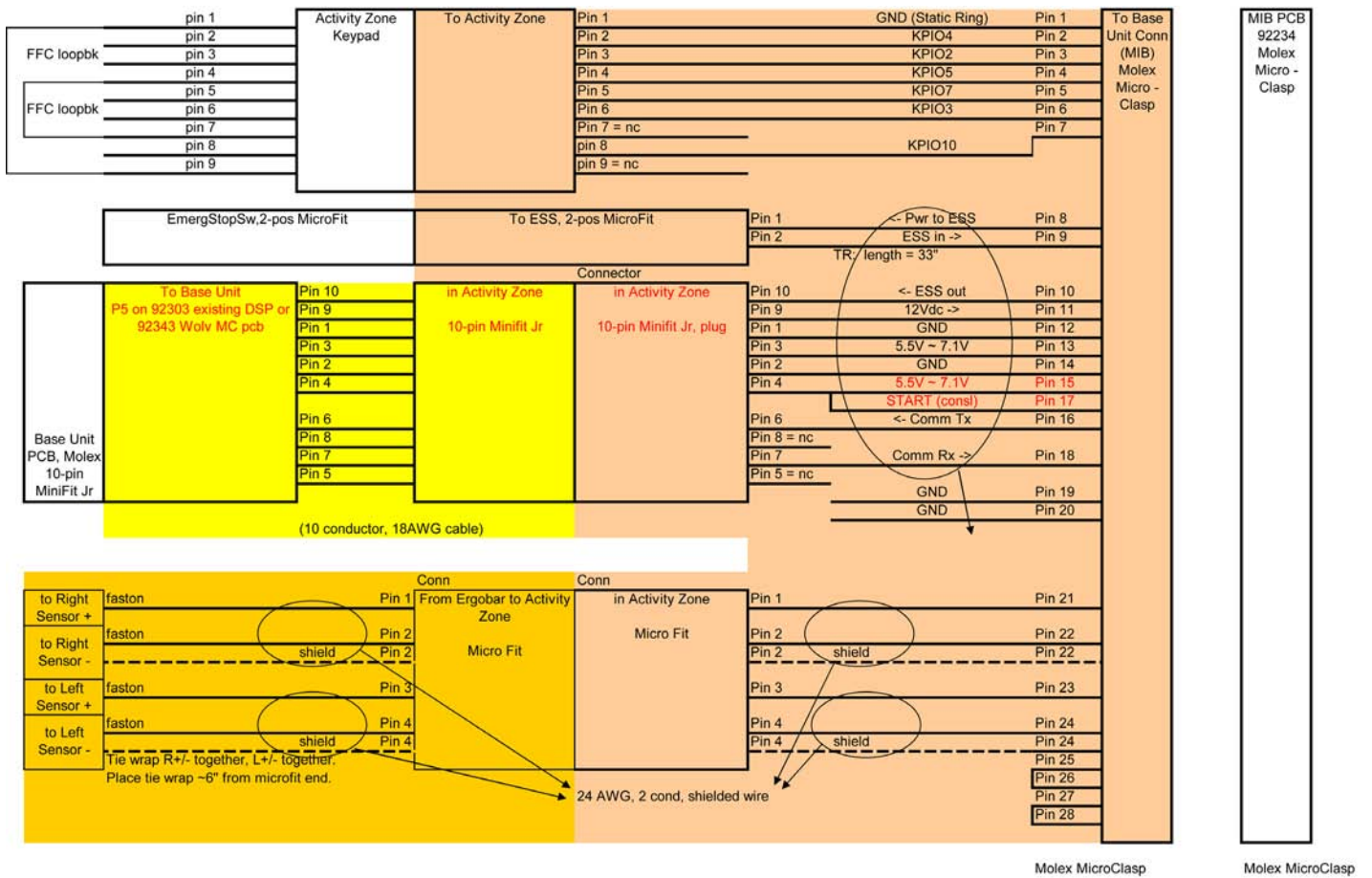

## Heart Rate System: Lifepulse® Theory of Operation

M051-00K65-A003

The Lifepulse® contact heart rate system is designed to sense the electrical signals originating from the heart as it beats and, using software, compute and display the corresponding heart rate value on the console readout. The two pairs of electrodes on the Treadmill Ergo bar (left and right) are the point of contact at which these signals are picked up and transmitted from the body to the Lifepulse® circuitry. A hands-on detect circuit monitors for a change in voltage corresponding to the input for each of the left and right sensor pairs to determine if either or both are being held. Both sensors must be held in order for the electrical signal from the heart to be measured. This is similar to measuring the voltage of a battery with a voltmeter. In order to measure a battery the voltmeter must be connected across the battery terminals (one lead to the positive and one lead to the negative). Similarly, the heart can be thought of as a voltage source or battery and in order to measure its voltage you must measure across its terminals. Essentially, when the left and right sensors are held they act like the leads of the voltmeter. Since an electrical path exists from the electrodes held in one hand, up the arm, across the body (and the heart), down the other arm and into the other hand holding the other pair of electrodes, a voltage can be measured. This is how the Lifepulse® signal is measured. And just like measuring a battery, the polarity of the voltage is important so the left and right electrodes must correspond to the left and right user hands.

To pick up the heart signal Lifepulse® must use a very sensitive high gain differential amplifier. This is primarily due to the signal's initial low amplitude as it originates from the heart (typically less than 2 millivolts peak to peak) and the resultant attenuation, or signal drop, as it travels through the body and into the electrodes. This type of amplifier is different from a regular amplifier in that only the differences between the inputs are amplified. In this way common signals, typically electrical noise, appearing on both inputs can be simultaneously ignored while the differences are amplified.

The output of this high gain differential amplifier, when neither or only one electrode pair is held, is meaningless because the inputs to the amplifier basically act as antenna picking up and amplifying stray electrical signals from the environment. Ideally, once both electrode pairs are held, as detected by the hands-on circuitry, the heart signal can be isolated, amplified and presented to the software for analysis. In practice however, additional unwanted signals exist. Some of these signals come from other muscles which lay along the "voltage" path to the heart being measured (such as arm and chest muscles). Similarly, hand to electrode contact problems which tend to weaken the signal or even introduce new signals which hide the actual heart signal can occur. The Lifepulse® software attempts to isolate just the heart signal from all other unwanted signals and noise using complex software techniques.

Basically, the Lifepulse® software samples the amplified signal picked up at the electrodes many times a second looking for the heart pulses. Depending upon the amount of noise, size of signal and/or irregularity of the heart pulse, it may take many seconds (from 4 to 20 or more) to confidently determine a value. And if a value cannot be confidently determined, a heart rate will not be displayed. To increase the detection of a heart signal, the Lifepulse® software attempts to expand the sampled signal to maximize the important features. A Gain value which represents the relative amount the signal was expanded is displayed in the Lifepulse® diagnostic screen and can range from 1 to 99. An assessment of the strength of the signal can be directly related to this gain value.

Input signals already at maximum levels require a low gain because their features cannot be further expanded without losing information. Very weak signals require more gain thus expanding them to full scale so their features can be easily picked out. This scaling is done dynamically over consecutive blocks of samples with each gain computed relative to the highest signal component within that block. The strength of the signal determines the effectiveness of the scaling.

In general, weak signals are less desirable than strong ones and very strong signals are less desirable than weaker ones. Obviously, weak signals requiring high gain values means that the weak heart pulses will be competing with other low level background noise when both are scaled up making it hard to determine the heart signal from the background signals. On the other hand, strong signals, usually not from the heart pulse itself, will ultimately limit the amount of scaling that can be applied. Typical gain values for low noise signals which produce good Lifepulse® heart rates are generally between 10 and 30. Above 30 means the heart signal is weaker and below 10 means other noise signals are too strong thus overpowering the heart pulses. Just as the gain value indicates the strength of the heart signal the Confidence number indicates the quality of the heart rate reading when one is displayed.

## Heart Rate System: Lifepulse® Theory of Operation

M051-00K65-A003

---

The LifePulse® software uses many methods to analyze the heart signal and zero in on the heart rate reading. The Confidence number which is also displayed in the LifePulse® diagnostic display indicates the agreement in the computed heart rate number among these different methods and therefore the confidence the heart rate displayed is correct. This is important when Cardio workouts, which change the load based on the difference between the current and target heart rates, are used. If a confident heart rate cannot be determined Cardio workout programs cannot automatically adjust the load to reach the target heart rate. Confidence values can range from 0 to 9 with 0 being the least confident reading and 9 being the most confident. Cardio program load changes occur when heart rate readings have confidence values of 5 or higher.

Some factors which affect LifePulse®'s ability to determine a heart rate:

- Hand slip and/or grip pressure changes on electrodes

*This can produce noise spikes which drives up gain values and lowers the ability to detect the features of the actual heart pulses.*

- Dry and/or calloused hands

*This can further reduce the already low amplitude heart signal picked up from the hands by the electrodes.*

- Dirty and/or contaminated hands

*This can also reduce the signal being measured.*

- Amount of upper body movement

*This can add signals which must be evaluated and filtered out in the software. Sometimes these signals can be regular enough to look like heart pulses.*

- Individual's own heart pulse amplitude

*Other noise signals compete with the low heart signals.*

- Irregular heart rhythms

*Missing, skipped or irregular heart beats require longer sample times to compute.*

# Heart Rate System: System Components

M051-00K65-A003

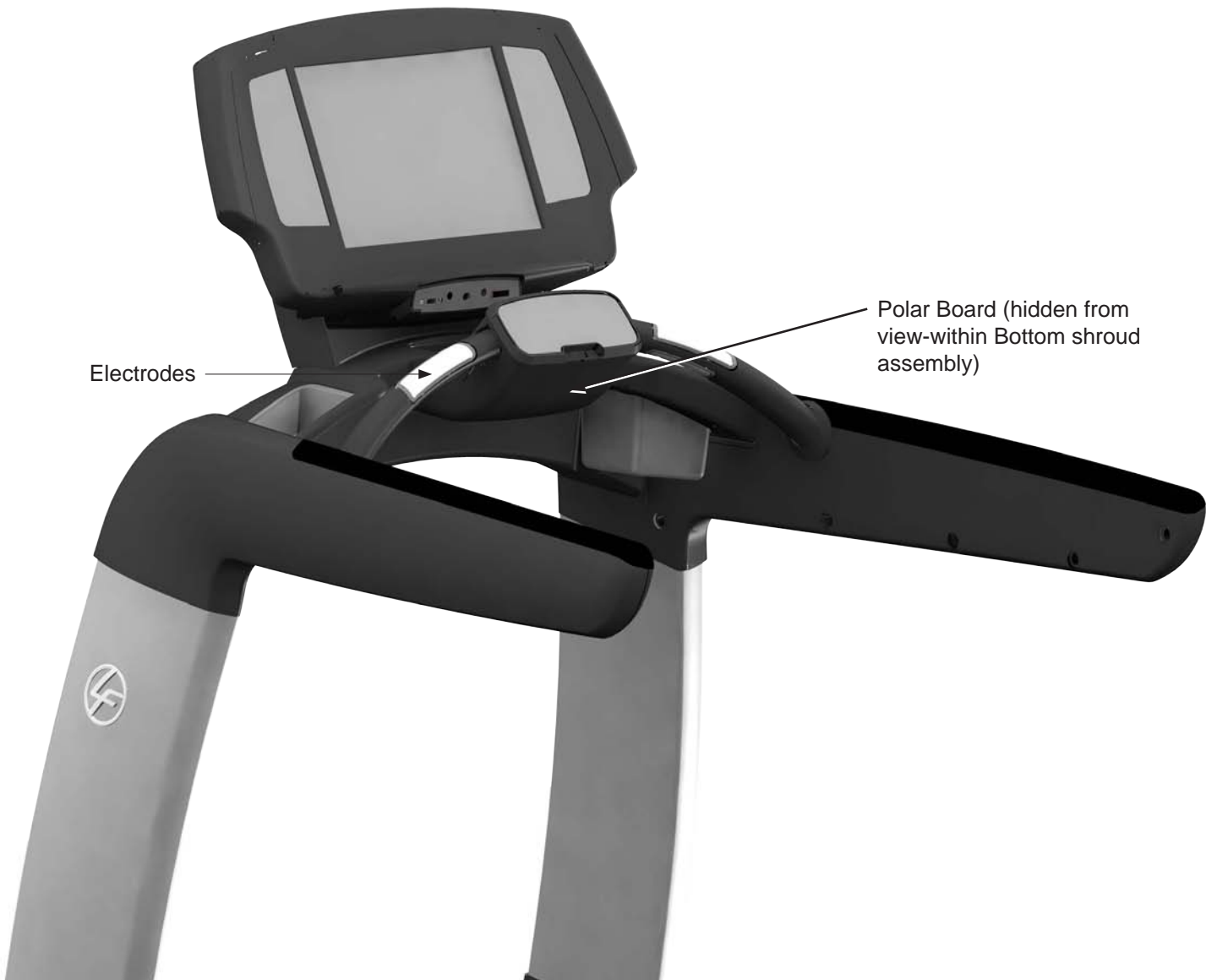

## View of Polar on Bottom Shroud

Polar Board in bottom shroud assembly



**Heart Rate System: Problem Symptom Table**

M051-00K65-A003

SYMPTOM	POSSIBLE CAUSE	SECTION	PAGE
Heart rate system inoperative	Damage	Check connections	HR 5
	Not connected	Replace heart rate sensors	
Polar issues	Inadequate grounding Cosmetic flaws	Replace Polar Board assembly	HR 6
No/erratic heart rate	No/erratic heart rate diagnostic		
Ghost heart rate	Ghost heart rate diagnostic		
Heart symbol displayed without hands on	Hardware diagnostics screening		



# Heart Rate System: How To's

M051-00K65-A003

## REPLACEMENT OF HEART RATE SENSORS

1. Remove and save the two Phillips screws that secure each set of rate electrodes to the Ergo bar.
2. Note which wires go to the top electrode and which go to the bottom electrode.
3. Disconnect the wires from both electrodes.
4. Plug the wires into the new electrodes.
5. Position the electrode gaskets between the electrodes and the Ergo bar. Please note that some Ergo bar gaskets are adhered to the Ergo bars (A later design change).
6. Install the new electrodes in the Ergo bar, using the screws removed and saved in Step 1.
7. Test the unit to verify that the new electrodes are working properly by operating the heart rate system.

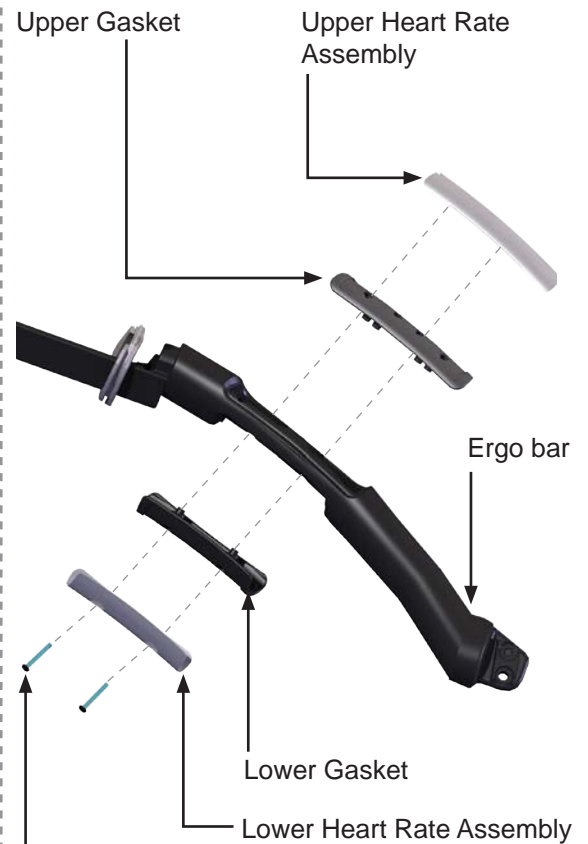

Phillips Screws (2)

Torque to  
7-11 in\*lb.  
[8-12.7 kg\*cm]

**REPLACEMENT OF POLAR BOARD ASSEMBLY**

1. Remove Activity Zone (See [CA 22](#)).
2. Remove the bottom shroud (See [UF 4](#)).
3. Remove / replace board and tape.
4. Replace bottom shroud.
5. Replace Activity Zone.

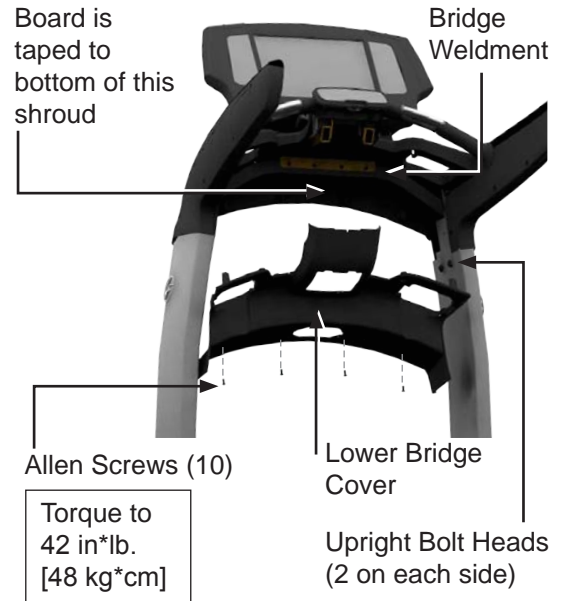

Non-coded Polar Board Receiver

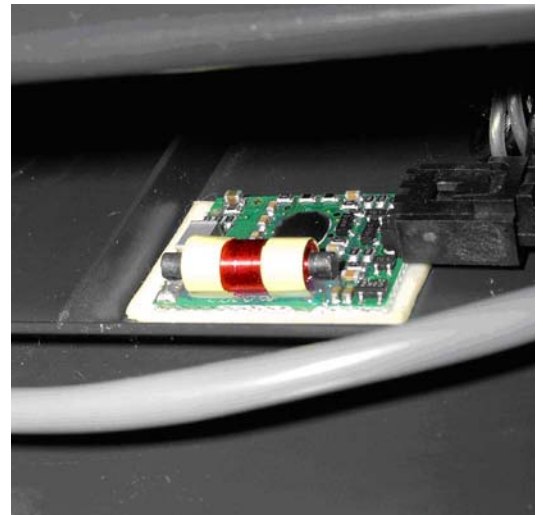

Coded Polar Board Receiver

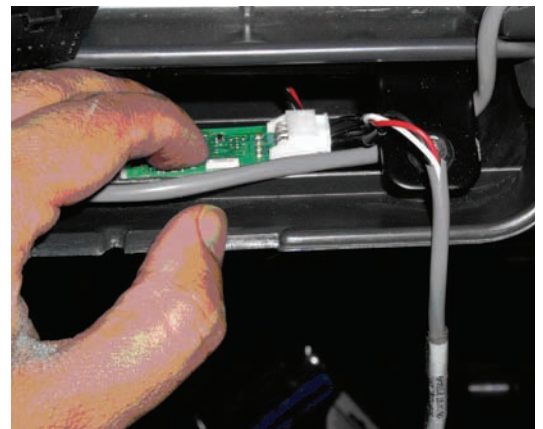

Please be statically grounded when handling the Printed Circuit Board (.e.g. anti-static wristband).

## Stride (Walking) System: Theory of Operation

M051-00K65-A003

The Stride System is comprised of the striding belt, the deck, the belt barrier, the Life Spring suspension components, the front and rear rollers, the rear roller guards and the stride sensor assembly. (see page SS-4).

The striding belt is impregnated with a lubricant. The deck is also coated with a paraffin wax on both faces. This combination allows for low friction between the striding belt and the deck which results in increased belt/deck life. The striding belt and deck are wear items and when the friction becomes large enough, the user may experience speed slow-downs. This slowdown is an indication that the belt and deck need to be replaced. The deck may be flipped over if it has never been flipped previously. In addition the console may display the message "UNABLE TO ATTAIN TARGET SPEED".

The striding belt is initially tensioned and centered about the rollers at the factory. The striding belt may have to be re-centered at the customer site during installation because of customer floor irregularities. These irregularities may also require the leveling of the treadmill by adjusting the rear leveler feet. The centering adjustment is done via two adjusting screws at the rear roller. With normal usage, the striding belt stretches over time which may cause the front roller to slip. This is an indication that the striding belt has to be re-tensioned. Re-tensioning is done by turning the adjusting screws. A simple method of determining if a belt is loose is the 2 mph stall test. This test requires the treadmill to run at 2 mph and the technician stomps hard on the striding belt to try to stall the motor while observing whether the front roller spins when the striding belt momentarily stops.

During treadmill use and depending how a user runs on the treadmill, the striding belt may move to either side causing the belt to go off center. To aid with this the front and rear rollers are tapered at the ends. This feature helps the striding belt center itself during use. In addition, the treadmill frame has belt guides at each side known as belt barriers. The purpose of the belt barriers is to contain the striding belt from walking off the edge of the rollers and being damaged during use.

The striding belt has a Life Fitness logo on the edge of each side which identifies the belt as an authentic Life Fitness part. The purpose of the logo is a visual warning that indicates whether the striding belt is moving in the event that a user gets off the treadmill during the workout and does not press the stop button to end the workout. In order to minimize how long a unit is running without a user on it, there is a sensor which senses deck movement. It is located on the treadmill frame under the deck. This is the Stride Sensor assembly. Deck movements are sensed by the stride sensor assembly which are converted to voltage signals and sent to the controller. If there are no deck movements, the controller sends a signal to the console indicating the absence of a user to end the workout.

The Life Spring suspension system is comprised of a set of eight proprietary elastomers that work in combination with the deck to reduce stress to bones and joints by absorbing some of the impact loads associated with running.

# Stride (Walking) System: System Components

M051-00K65-A003

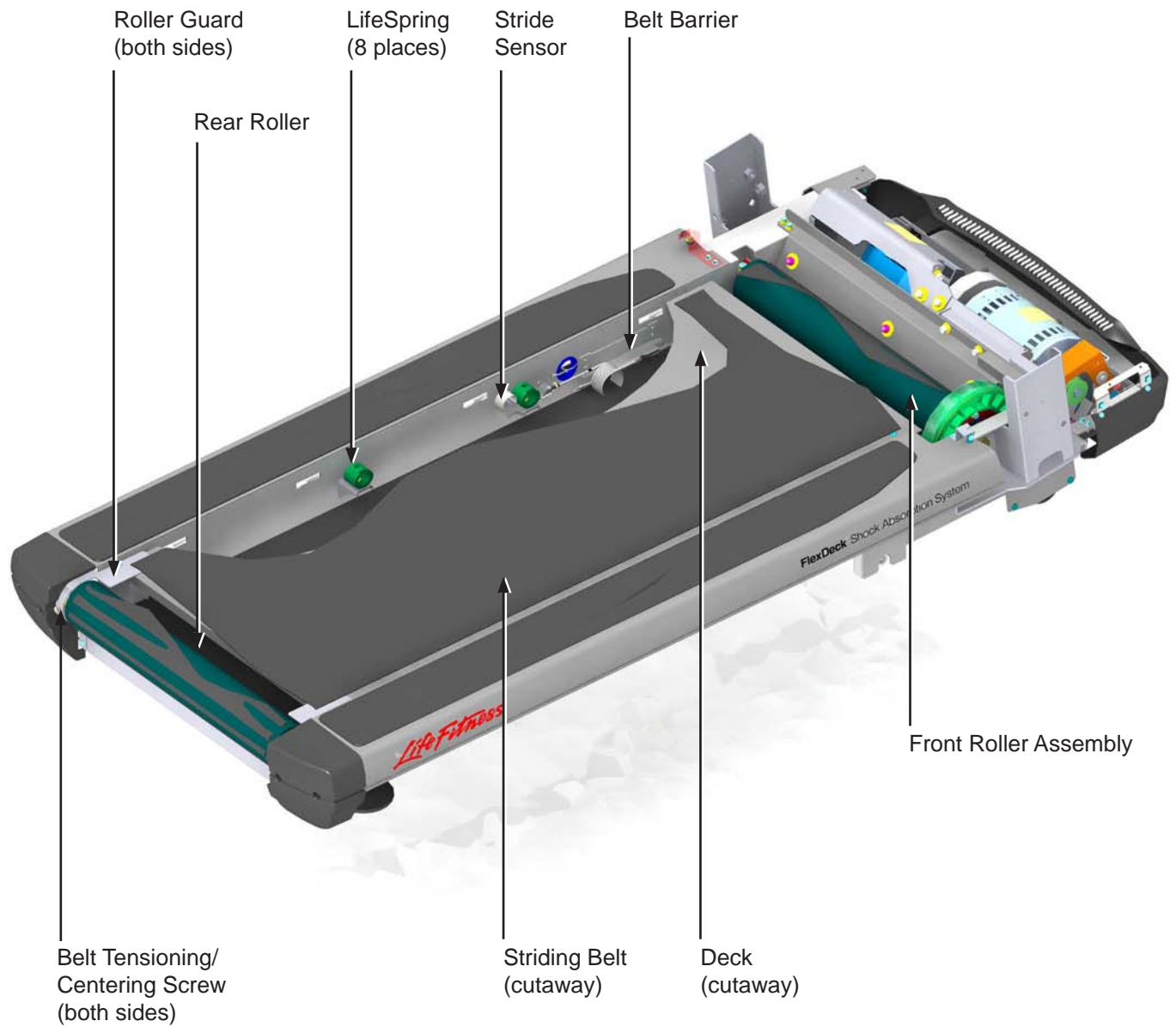

# Stride (Walking) System: Problem Symptom Table

SYMPTOM	POSSIBLE CAUSE	SECTION	PAGE
<p>Selected or maximum speed is reduced during workout.</p>	<p>Insufficient line voltage/ current at the outlet due to unit plugged into a shared (non-dedicated) outlet.</p>	<p>Unplug the treadmill and carefully open outlet cover and count number of conductors going to outlet. If there are more than three wires on a single outlet or more than five wires on a dual outlet the outlet is a shared outlet. Unit must be plugged into a dedicated outlet. See operation manual for power requirements.</p>	<p>N/A</p>
	<p>Worn deck and/or worn striding belt.</p>	<p>Set unit to 15% incline. While standing on striding belt close to the Ergo bar, push off Ergo bar. If steady, continuous sliding occurs down the incline, the belt/deck wear is acceptable. If sliding is not continuous replace striding belt and deck (or flip deck if deck has never been flipped before).</p>	<p>SS 8</p>
	<p>Drive motor binding.</p>	<p>Check drive motor shaft for binding or roughness. Replace motor if necessary.</p>	<p>DS 3</p>
	<p>Front or rear roller binding.</p>	<p>Inspect rollers for binding or roughness. Replace if necessary.</p>	<p>SS 6</p>
<p>Striding belt slips.</p>	<p>Incorrect striding belt tension.</p>	<p>Do the two mph stall test by stomping on the striding belt hard at two mph. If the front roller spins when the striding belt momentarily stops the belt tension must be increased.</p>	<p>SS 8</p>

# Stride (Walking) System: Troubleshooting

SYMPTOM	POSSIBLE CAUSE	SECTION	PAGE
Striding belt not centered or traveling close to roller edges.	Treadmill not level.	Level treadmill by adjusting the leg levelers.	
	Striding belt not within belt barriers.	Position striding belt inside belt barrier on both sides of the frame.	SS 8
	Striding belt not tracking properly (belt is off to the left or the right).	Adjust the tracking of striding belt.	SS 8
	Worn striding belt.	Set unit to 15% incline. While standing on striding belt close to the Ergo bar push off Ergo bar. If steady continuous sliding occurs down the incline, the belt/ deck wear is acceptable. If sliding is not continuous replace striding belt and deck (or flip deck if deck has never been flipped before).	SS 8
Grinding noise on footfall.	Excessive friction between deck and striding belt.	Set unit to 15% incline. While standing on striding belt close to the Ergo bar push off Ergo bar. If steady continuous sliding occurs down the incline, the belt/ deck wear is acceptable. If sliding is not continuous replace striding belt and deck (or flip deck if deck has never been flipped before).	SS 8
Squeaking noise when striding belt moves.	Worn or damaged main motor drive belt.	Inspect the main drive belt for damage or wear and replace if necessary.	DS 3
	Drive motor pulley and front roller pulley misaligned.	Align pulleys as described in drive motor module.	
Rubbing sound from under the treadmill when striding belt is moving.	Striding belt not positioned properly between the belt barrier.	Position striding belt edges to be between belt barrier.	
	Striding belt not centered and off to the left or to the right.	Center striding belt.	

**Stride (Walking) System: Troubleshooting**

M051-00K65-A003

SYMPTOM	POSSIBLE CAUSE	SECTION	PAGE
Knocking noise	Treadmill not level.	Level treadmill by adjusting the leg levelers.	
	Faulty front and/or rear roller bearings.	Inspect rollers for binding or roughness. Replace if necessary.	
	Lifesprings incorrectly positioned and/or have loose mounting hardware.	Inspect lifesprings and mounting hardware and reposition or tighten.	
Treadmill goes into pause mode during workout.	Physical damage to stride sensor.	Check stride sensor for physical damage and replace stride sensor if necessary.	
	Stride sensor not sensing user.	Go into diagnostics and check stride sensor operation.	

**REMOVAL OF FRONT AND REAR ROLLER**

1. Turn the treadmill power switch off.
2. Unplug the line cord from the wall outlet.
3. Remove motor cover and rear end caps (See [LF 3](#))
4. Remove rear end caps.
  
5. Remove rear roller guards
  
6. Loosen walking belt by turning tensioning screws counterclockwise. Count the number of turns to remove the screw This will simplify re-tensioning the striding belt to the same tension.

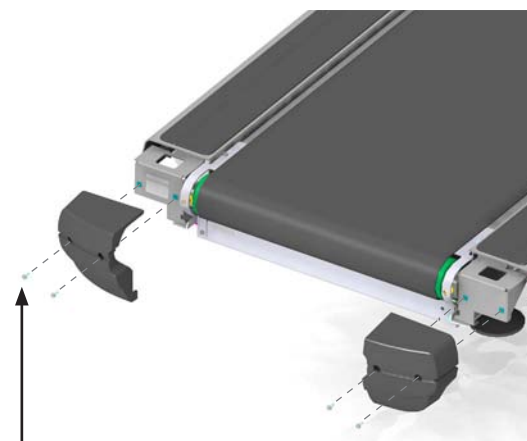

End Cap Screws  
(25-35in-lbs)  
[29-40 kg-cm]

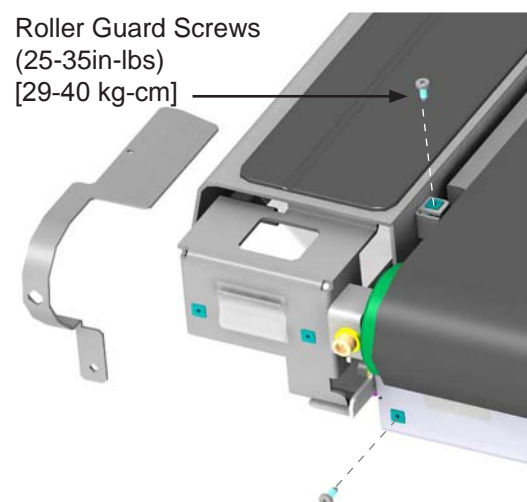

Roller Guard Screws  
(25-35in-lbs)  
[29-40 kg-cm]

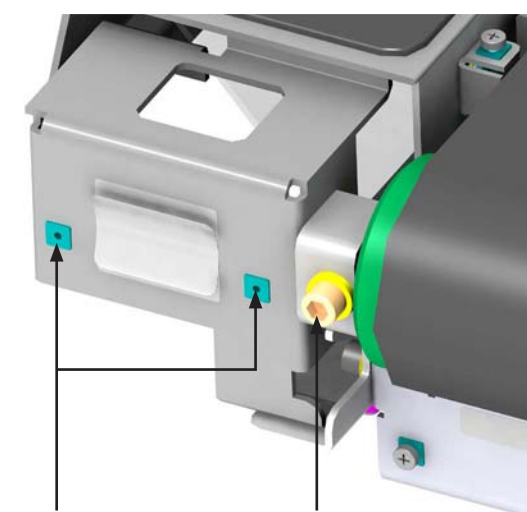

Plastic grommet  
(nut) typical

Tensioning screw  
and washer



7. Remove rear roller.

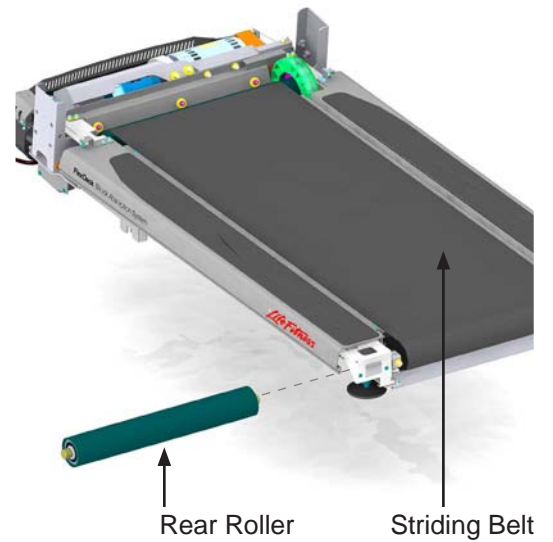

8. Remove drive belt from motor pulley (See DS 3) and walk drive belt off of front roller pulley.

9. Remove front roller mounting bolt and washers and slide front roller towards the left until roller shaft is clear of the mounting hole in frame.

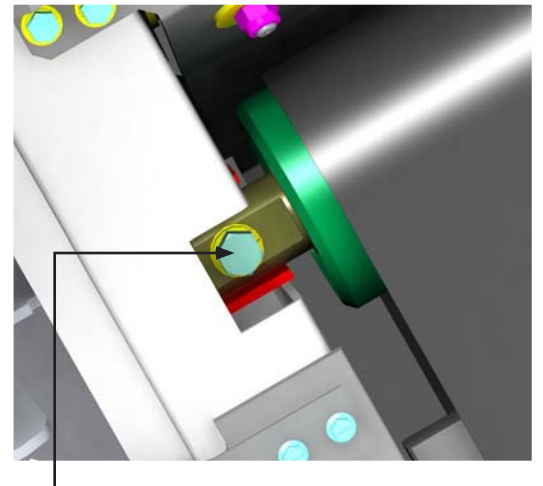

Front Roller Bolt, Washer, Flat Washer  
(12-14 ft-lbs) [16-19 N-m]

10. Remove front roller assembly from right side.

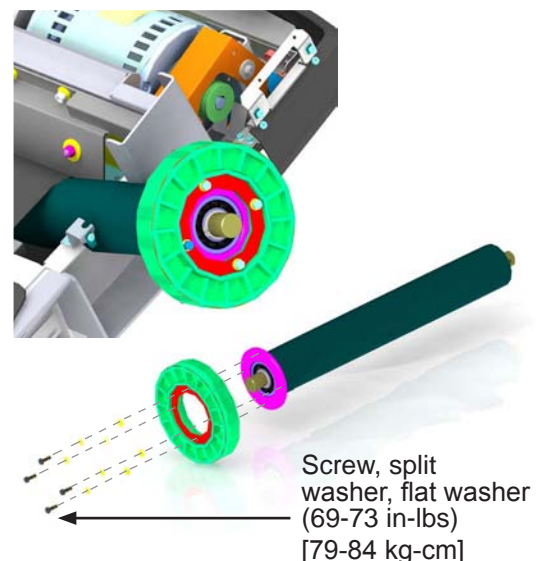

**REMOVAL & INSTALLATION OF STRIDING BELT AND DECK**

1. With the front and rear rollers and other components removed as described in the previous section remove the 4 deck screws and remove the deck from between the belt.

**CAUTION:** Be careful not to damage the stride sensor with the deck .

2. Remove striding belt.

**CAUTION:** Be careful not to damage the stride sensor when removing the striding belt.

3. Install new Tinnerman clips on the 4 corner LifeSprings.

**NOTE:** Proper assembly

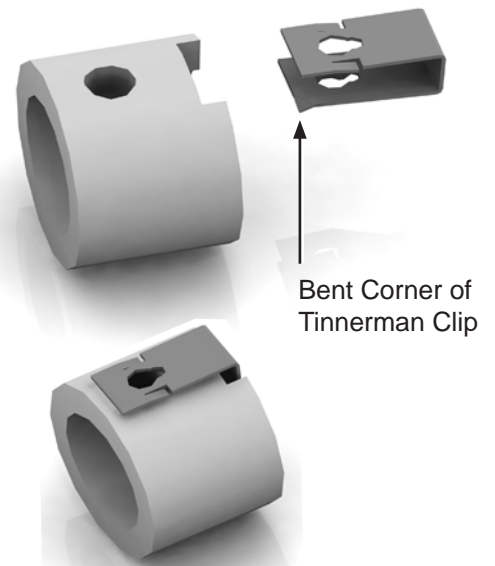
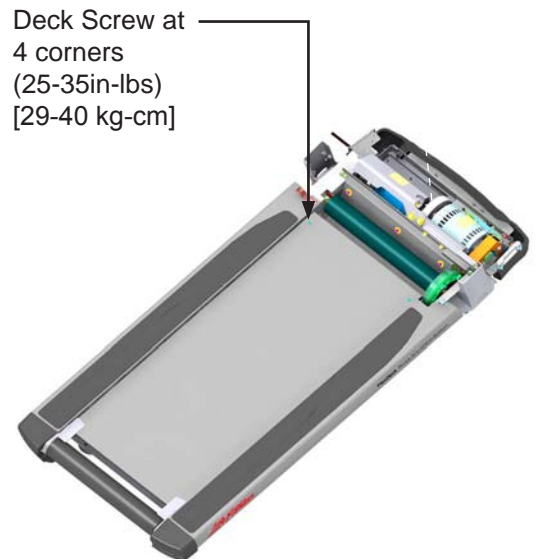
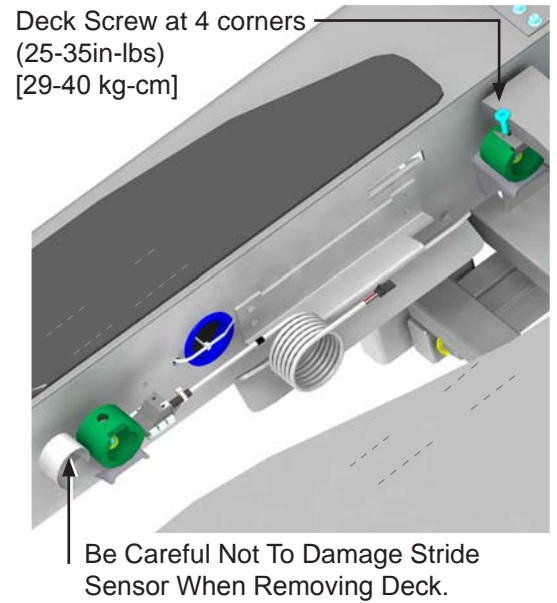

# Stride (Walking) System:How To's

M051-00K65-A003

4. To install new striding belt, place new belt with arrow on belt pointing in the direction of belt travel.
5. Scrape off any wax build up on the front roller surface using a plastic spatula.
6. Install front roller assembly with drive belt over roller pulley. Tighten mounting bolt to 12-14 ft-lbs [16-19 N-m]
7. Scrape off any wax build up on the rear roller using a plastic spatula.

8. Position rear roller through striding belt and let it rest on rear roller brackets.

9. Insert new deck through the striding belt and place on the LifeSprings carefully without damaging the stride sensor. Existing deck may be flipped if it has never been flipped before.

**CAUTION:** Clean underside of deck of any debris if being flipped.

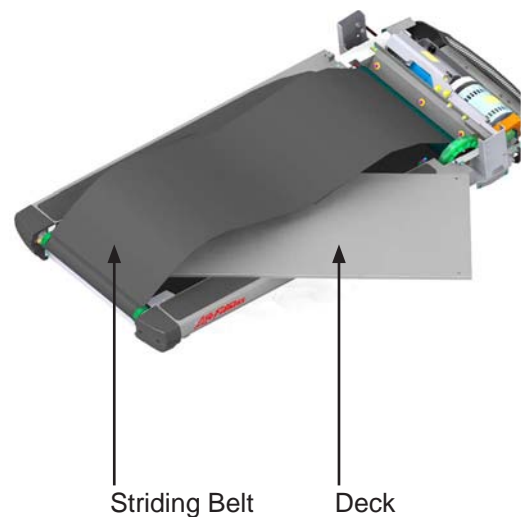
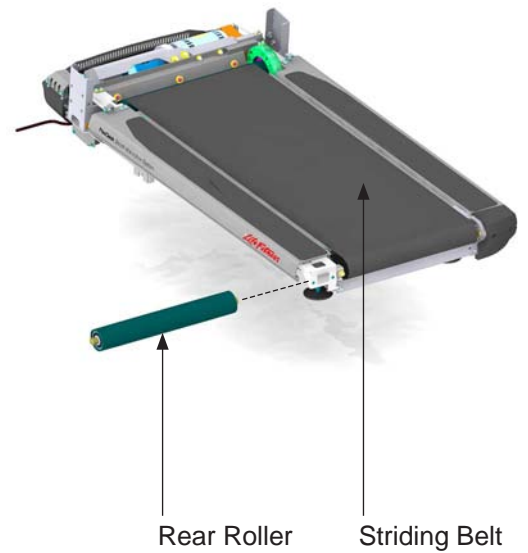
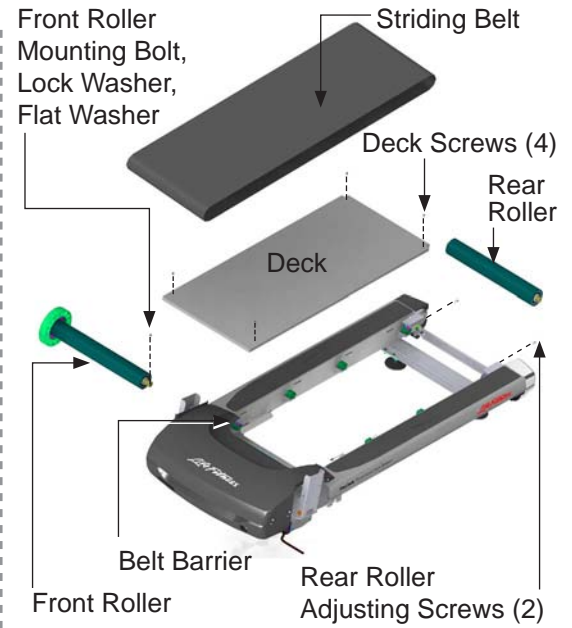

# Stride (Walking) System:How To's

- Secure the deck with deck screws. Line up holes in deck with Tinnerman clip holes. Push down on deck and install screw.

**CAUTION:** Apply light pressure on screw to avoid bending the Tinnerman clip

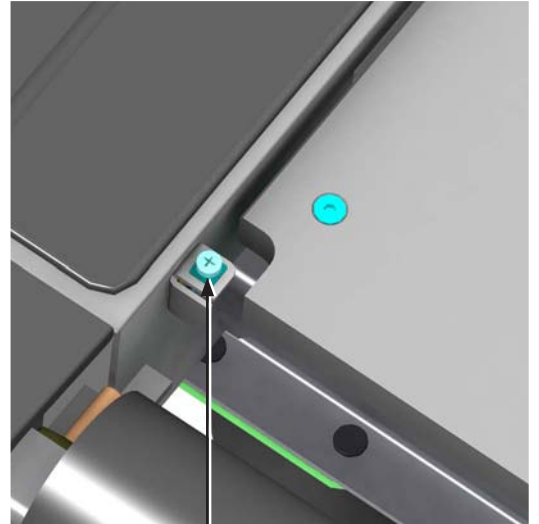

Orientation of deck with cutout facing the rear

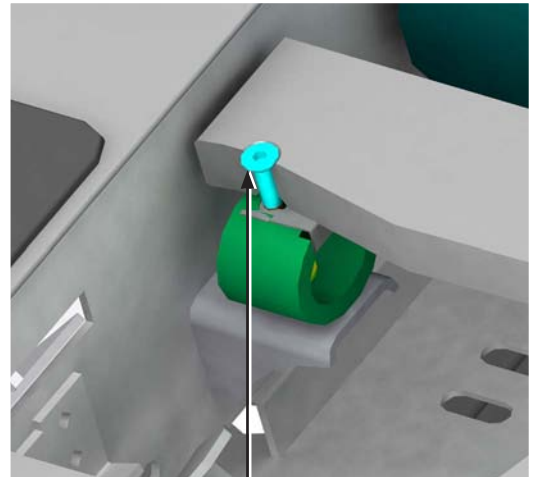

Deck screw at 4 corners  
(25-35in-lbs) [29-40 kg-cm]

- Center the striding belt about the front and rear rollers at approximately 1/2 inch from rear roller edge. Also position the belt edges within the belt barrier.

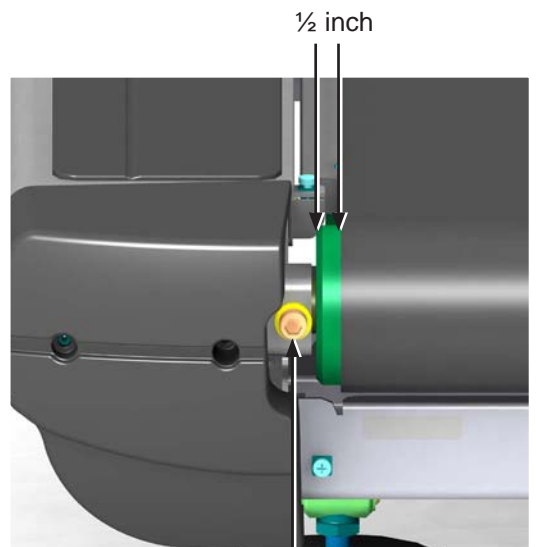

Tensioning Bolt

# Stride (Walking) System:How To's

12. To properly tension a new striding belt without the use of tension gauges, place two pieces of masking tape exactly 38.75 inches apart on the right and left edges as shown (four pieces total). Alternatively you can mark two lines 38.75 inches apart on the masking tape.
13. To tension the new striding belt, rotate the tension bolts clockwise until the distance between the pieces of tape (or lines on the tape) is increased to 39 inches for a NEW striding belt (38 15/16 inches for an existing belt).
14. Start the treadmill and run it at seven mph.

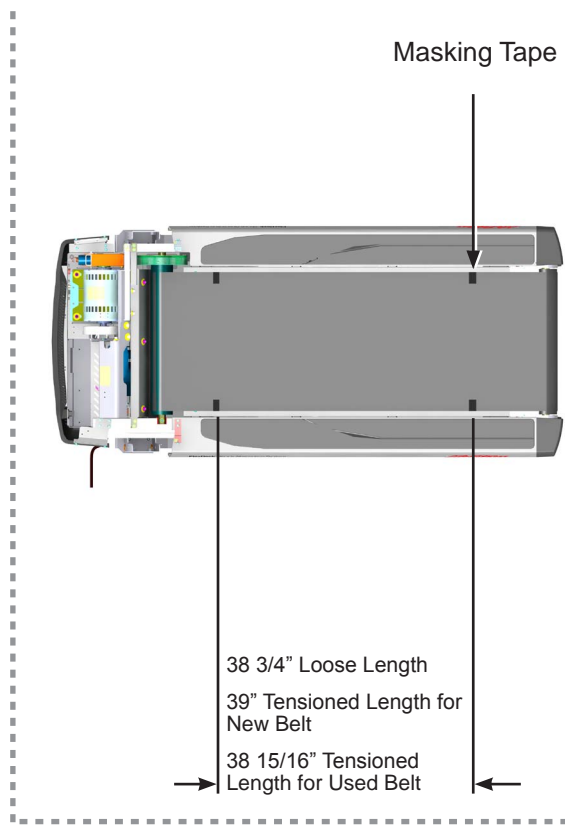

15. If the striding belt moves to the right, using a 5/16 inch Allen wrench, turn the right tension bolt 1/8-turn clockwise and the left tension bolt 1/8-turn counterclockwise to start centering the striding belt about the rear roller.
16. If the striding belt moves to the left, turn the left tension bolt 1/8-turn clockwise and the right tension bolt 1/8-turn counterclockwise to start centering the striding belt about the rear roller.
17. Continue adjusting belt until it is centered and does not move to one side or the other.
18. Run treadmill at two mph and while on treadmill come down hard on the striding belt. If the front roller spins when the striding belt momentarily stops, the belt is loose.
19. If the belt is loose, tighten it by rotating each tensioning bolt 1/4 turn clockwise and repeat steps 14 to 16 until the front roller does not spin.

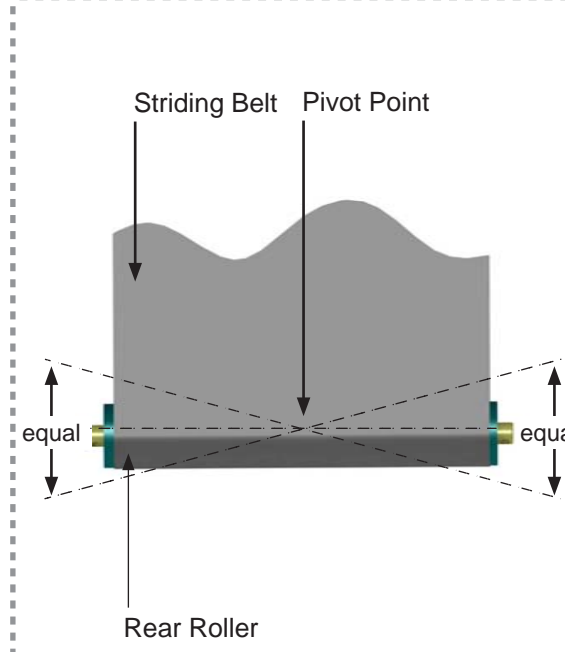

# Stride (Walking) System:How To's

## REMOVAL OF STRIDE SENSOR ASSEMBLY

1. Loosen striding belt. (See [SS 8](#))

**NOTE:** Don't forget to count the number of turns on the tensioning bolt required to loosen the belt and remove the deck. This will simplify re-tensioning the belt to the same tension.

2. Remove deck. (See [SS 8](#))

**CAUTION:** Be careful not to drop the deck on the stride sensor.

3. Disconnect stride sensor cable connector from controller in motor pan.
4. Fish cable through frame.

**NOTE:** Tying a cord on the end of the connector will help to fish the new cable through the frame.

5. Remove existing stride sensor.

6. Install new stride sensor.

7. **NOTE:** Mount stride sensor parallel to frame as shown.

**NOTE:** Be careful not to damage the cable when fishing it through the frame.

8. Re-install the deck (See [SS 8](#))

9. Re-tension the striding belt (See [SS 8](#))

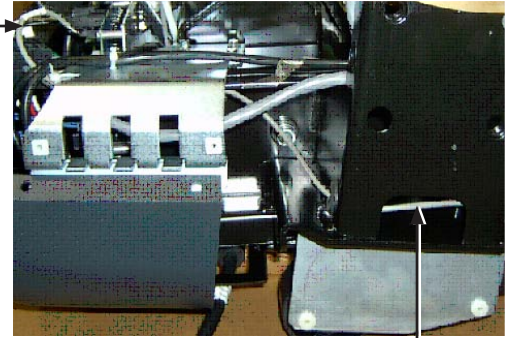

Stride Sensor Cable Routing Through 3 Grommets in Frame

Stride Sensor Connector at Controller

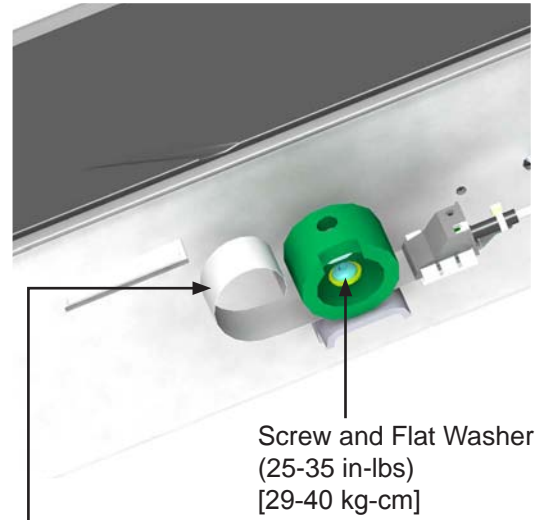

Screw and Flat Washer (25-35 in-lbs) [29-40 kg-cm]

Stride Sensor Assembly

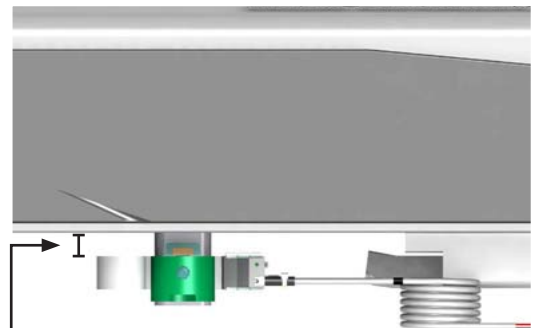

5/8" [5.9mm]

# Lower Frame: System Components

M051-00K65-A003



**Lower Frame: Problem Symptom Table**

M051-00K65-A003

SYMPTOM	POSSIBLE CAUSE	SECTION	PAGE
Anti-slip pad assemblies are loose	Pad not properly placed or damaged.	Replace anti-slip pad.	<a href="#">LF 7</a>
Motor shroud cover is off or loose	Improper placement	Replace motor shroud cover.	<a href="#">LF 3 (Top)</a>
	Damage		<a href="#">LF 5 (Bottom)</a>
Loose upright covers	Improper placement	Replace upright covers.	<a href="#">LF 4</a>
	Damage		
Loose uprights	Damage	Replace uprights.	<a href="#">LF 3</a>
Loose end caps	Improper placement	Replace end caps.	<a href="#">LF 5</a>
	Damage		
Lower extrusion loose or off	Improper placement	Replace lower extrusion.	<a href="#">LF 6</a>
	Customer abuse		



### REPLACEMENT OF TOP MOTOR SHROUD COVER

1. Remove and save the six Phillips screws that secure the top motor shroud cover to the motor cover mounting brackets and frame.
2. Install the new top motor shroud cover using the Phillips screws saved in Step 1.



### REPLACEMENT OF UPRIGHTS

1. Turn the treadmill power switch off.
2. Unplug the line cord from the wall outlet.
3. Remove the top motor cover.
4. Remove either right or left upright shroud depending on which upright is being replaced.
5. Remove the inside handrail covers (See [UF 3](#))
6. Remove the Activity Zone assembly (See [CA 22](#)).
7. Remove the outer handrail covers (See [UF 5](#)).
8. Remove the lower bridge cover (See [UF 4](#)).
9. Remove and save the six upper bolts (three per upright) that secure the bridge to the uprights.
10. Cables run through both of the uprights. Determining which cable will be disconnected will depend on which upright is being replaced. If replacing the left upright, this will require disconnecting the power cables to the attachable TV and re-routing them through the new upright. The transformer cable must be removed and rerouted if the left upright is being replaced.
11. Carefully lift the bridge frame assembly up and out of the uprights and set it to the side.
12. Remove and save the three lower bolts that secure the upright to the base frame.
13. Install the new upright using the hardware removed in the previous steps.

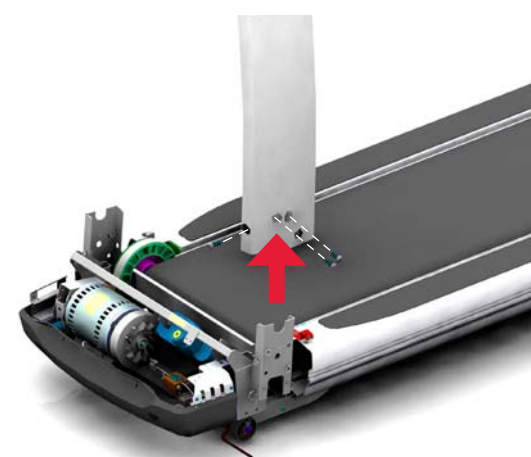

**REPLACEMENT OF UPRIGHT COVERS**

1. Remove the top motor shroud cover.
2. Remove and save the two Phillips screws that secure the upright cover to the upright.
3. Loosen the screw securing the upright cover to the main frame (in front of the upright).
4. Remove the upright cover.



5. Install the new upright cover, using the screws removed in Step 2.

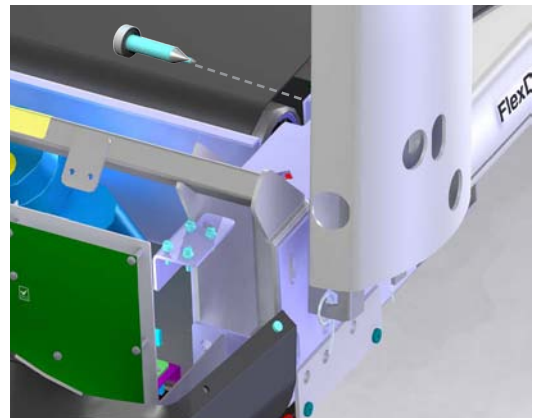
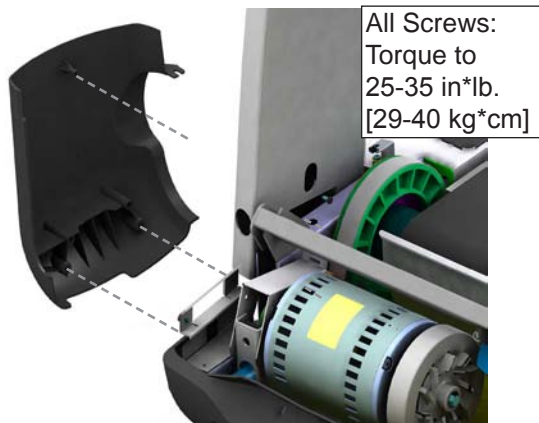

**Example of a Bad Gap**

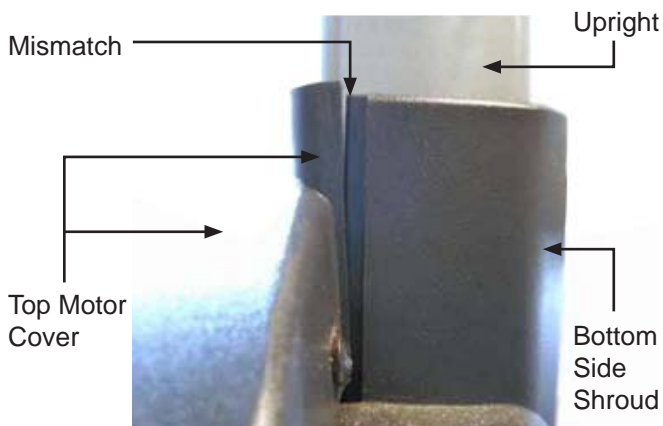

**Example of a Good Gap**



**REPLACEMENT OF END CAPS**

1. Remove and save the two Phillips screws that secure the right or left rear end cap to the frame.
2. Install the new rear end cap using the screws saved in Step 1.



**REPLACEMENT OF BOTTOM MOTOR SHROUD COVER**

1. Remove the top motor shroud cover (See [LF 3](#)).
2. Remove and save the four Phillips screws that secure the bottom motor shroud cover to the motor cover mounting brackets.
3. Install the new bottom motor shroud cover using the screws removed in Step 2.

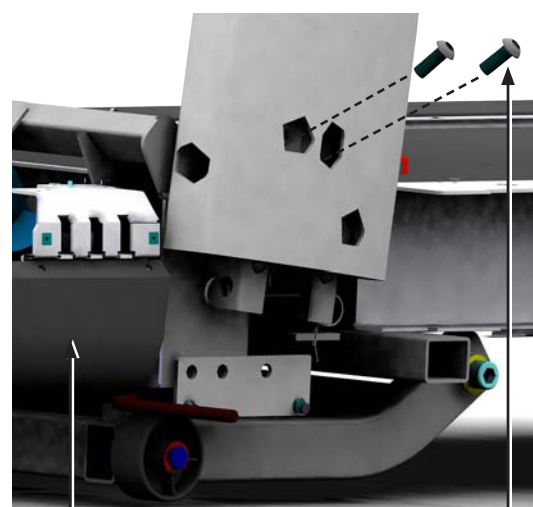

Lower Motor Shroud

Lower Motor Shroud Screws (2 of 4 shown)

Torque to 25-35 in\*lb. [29-40 kg\*cm]

# Lower Frame: How To's

M051-00K65-A003

## REPLACEMENT OF LOWER EXTRUSIONS

1. Remove the corresponding right or left rear end cap (See [LF 5](#)).
2. The lower frame extrusion is attached to the frame by a series of Velcro strips mounted along the length of the frame. Separate the Velcro strips and pull the lower frame extrusion out and away from the side of the treadmill.
3. Save the foam strip that is positioned between the upper and lower extrusions.
4. Install the new lower frame extrusion.
5. Install the foam strip by pressing it into the space between the lower and upper frame extrusions.

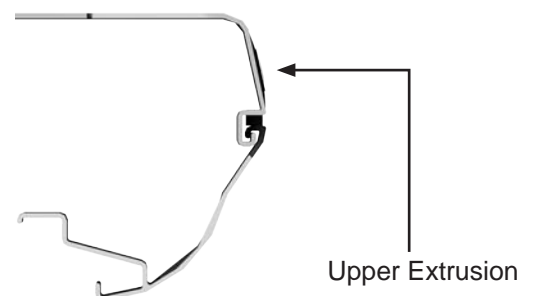
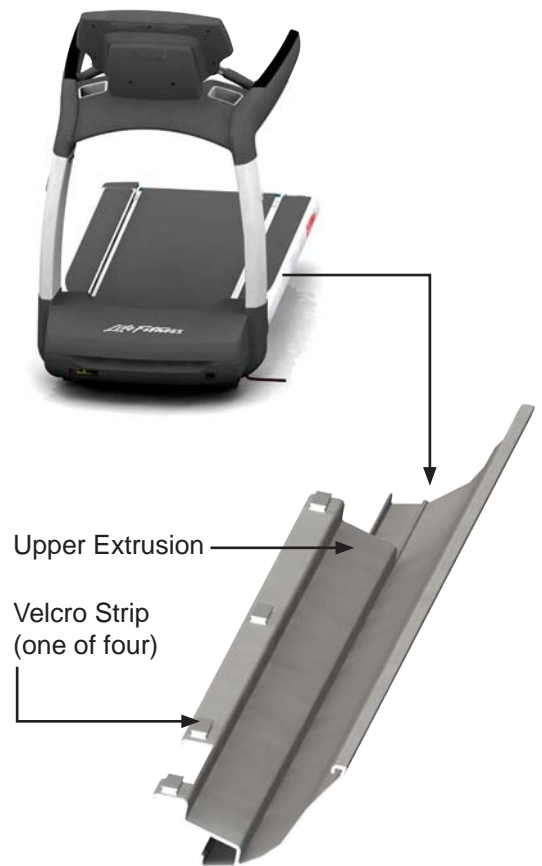
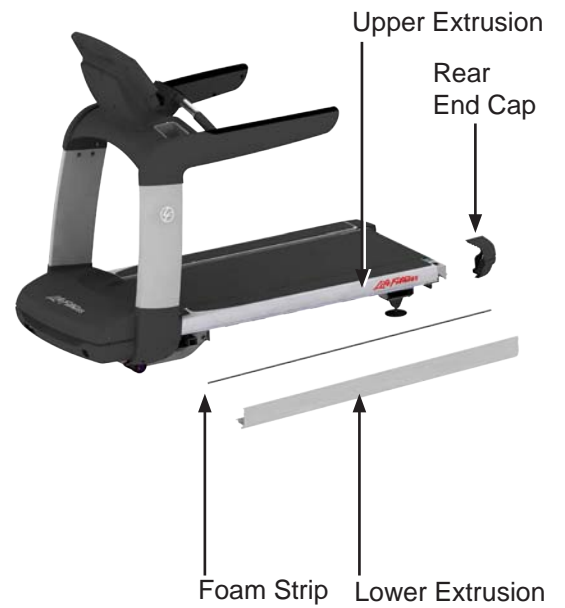

# Lower Frame: How To's

M051-00K65-A003

## REPLACEMENT OF UPPER EXTRUSION/ANTI-SLIP ASSEMBLY

1. Remove the top motor shroud cover (See [LF 3](#)).
2. Remove the upright shroud (See [LF 4](#)).
3. Remove the Phillips screws that secure the motor cover mounting bracket to the upper extrusion.
4. Note the location of the anti-slip pad.
  
5. Using a small flat blade screwdriver, carefully pry up one end of the anti-slip pad.
6. Continue to peel the anti-slip pad until it is completely removed from the extrusion.
7. Remove the lower extrusion (See [LF 6](#)).
  
8. Remove and save the nine screws that secure the upper extrusion to the frame.
9. Install the upper extrusion to the frame.
10. Peel the backing off the anti-slip pad.
  
11. Position the pad on the upper extrusion, using the locating tabs on the back of the anti-slip pad.
12. Press down firmly on the anti-slip pad to adhere it securely to the extrusion.

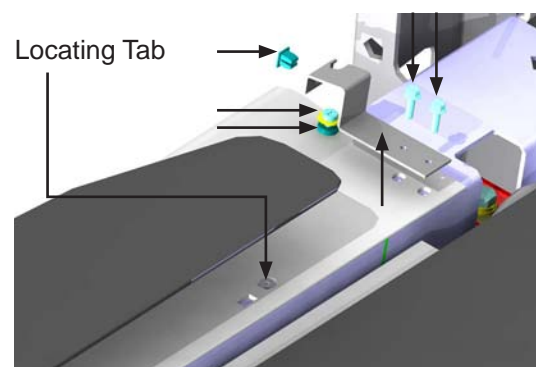

# Upper Frame: System Components

M051-00K65-A003



**Upper Frame: Problem Symptom Table**

M051-00K65-A003

<b>SYMPTOM</b>	<b>POSSIBLE CAUSE</b>	<b>SECTION</b>	<b>PAGE</b>
Inside handrail shroud loose or misaligned.	Improper assembly	Replace inside handrail shroud.	UF 3
	Damaged component		
Outside handrail shroud loose or misaligned.	Improper assembly	Replace outside handrail shroud.	UF 5
	Damaged component		
Upper bridge cover loose or misaligned.	Improper assembly	Replace upper bridge cover.	UF 6
	Damaged component		
Lower bridge cover loose or misaligned.	Improper assembly	Replace lower bridge cover.	UF 4
	Damaged component		
Handrail need loose or misaligned.	Improper assembly	Replace handrail.	UF 3
	Damaged component		

**REPLACEMENT OF INSIDE HANDRAIL COVERS**

1. Remove and save the five plugs in the inside handrail covers that conceal the mounting bolts.
2. Remove and save the five Allen bolts that secure the inside handrail cover to the handrail.



3. Remove the cover by tilting it forward the inside of the unit, then pulling down.
4. Install the new Inside Handrail Cover, using the bolts removed and saved in Step 2.





**REPLACEMENT OF LOWER BRIDGE COVER**

1. Turn the treadmill power switch off.
2. Unplug the line cord from the wall outlet.
3. Remove the cup holders.
4. Remove the Activity Zone assembly (See [CA 22](#)).
5. Remove and save the two Allen bolts that secure the lower bridge cover to the bridge weldment.
6. Remove and save the two Allen bolts that secure the lower bridge cover to the upper bridge cover.
7. Tilt the lower bridge cover to either side of the unit to enable the lower bridge cover to clear the upright bolt heads.
8. Remove the lower bridge cover.
9. Install the new lower bridge cover using the bolts removed and saved in Steps 5 and 6.



**Example of a Bad Gap**

**Example of a Good Gap**

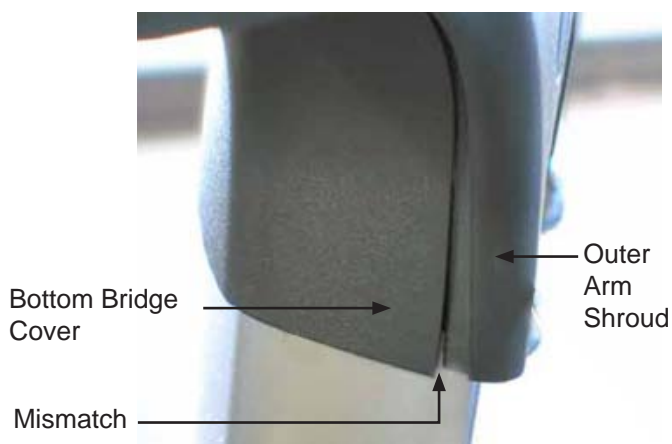

## Upper Frame: How To's

M051-00K65-A003

### REPLACEMENT OF OUTSIDE HANDRAIL COVERS

1. Turn the treadmill power switch off.
2. Unplug the line cord from the wall outlet.
3. Remove the cup holders.
4. Remove the handrail cover (See [UF 7](#)).
5. Remove the Activity Zone assembly (See [CA 22](#)).
6. Remove the lower bridge cover (See [UF 4](#)).
7. Remove and save the six Allen bolts that secure the outer handrail cover to the handrail.
8. Remove the outer handrail cover.
9. Install the new outer handrail cover using the bolts removed and saved in Step 7.

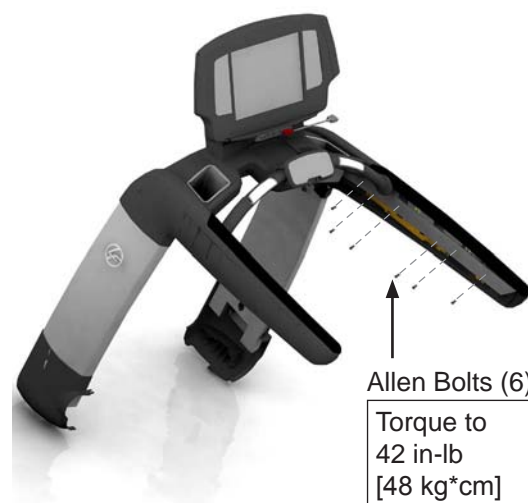

#### Example of a Bad Gap

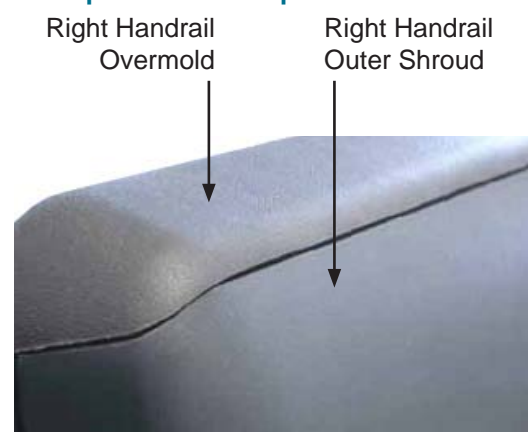

#### Example of a Good Gap



**REPLACEMENT OF UPPER BRIDGE COVER**

1. Turn the treadmill power switch off.
2. Unplug the line cord from the wall outlet.
3. Remove the cup holders.
4. Remove the console assembly.
5. Remove the console neck assembly.
6. Remove the inside handrail covers (See [UF 3](#)).
7. Remove the Activity Zone assembly (See [CA 22](#)).
8. Remove the lower bridge cover (See [UF 4](#)).
9. Remove the outer handrail covers (See [UF 5](#)).
10. Remove and save the six bolts.
11. Remove the upper bridge cover.
12. Install new upper bridge cover using the bolts removed and saved in Step 8.

Torque to  
42 in-lb  
[48 kg\*cm]



Example of a good gap

# Upper Frame: How To's

M051-00K65-A003

## REPLACEMENT OF HANDRAILS

1. Turn the treadmill power switch off.
2. Unplug the line cord from the wall outlet.
3. Remove the cup holders.
4. Remove the inside handrail covers (See [UF 3](#)).
5. Remove the Activity Zone assembly (See [CA 22](#)).
6. Remove the lower bridge cover (See [UF 4](#)).
7. Remove the outer handrail covers (See [UF 5](#)).
8. Remove and save the two bolts that secure the handrail to the Ergo bar.
9. Remove and save the two Allen bolts that secure the handrail to the upright.
10. Remove the handrail.
11. Install the new handrail using the bolts removed and saved in Steps 8 & 9.

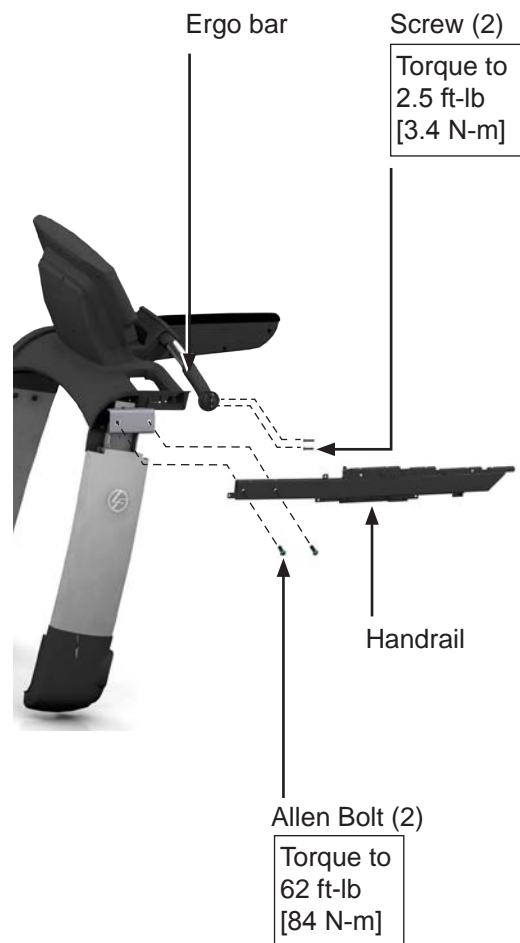

## REPLACEMENT OF ERGO BAR

1. Turn the treadmill power switch off.
2. Unplug the line cord from the wall outlet.
3. Remove the cup holders.
4. Remove the inside handrail covers (See [UF 3](#)).
5. Remove the Activity Zone assembly (See [CA 22](#)).
6. Remove the lower bridge cover (See [UF 4](#)).
7. Remove the outer handrail covers (See [UF 5](#)).
8. Remove and save the two bolts that secure the handrail to the Ergo bar.
9. Remove and save the three bolts that secure the Ergo bar to the bridge frame.
10. Disconnect the heart rate cable from the Ergo bar to the console.
11. Install the new Ergo bar assembly using the hardware removed and saved in Steps 8 and 9.



# *Appendix*

The background is a solid teal color with several curved, overlapping bands of a lighter shade of teal. These bands create a sense of movement and depth, starting from the right side and curving towards the left. The word "Appendix" is written in a white, italicized serif font in the upper left corner.

## **Engage / Inspire Console Diagnostic: Overview**

---

This document is intended to provide a high level overview of System Diagnostic flows as well as screen-by-screen layout and descriptions of their intended functionality for the Engage / Inspire consoles.

# Engage / Inspire Console Diagnostic: System Options - Block Diagram Overview

## System Flows

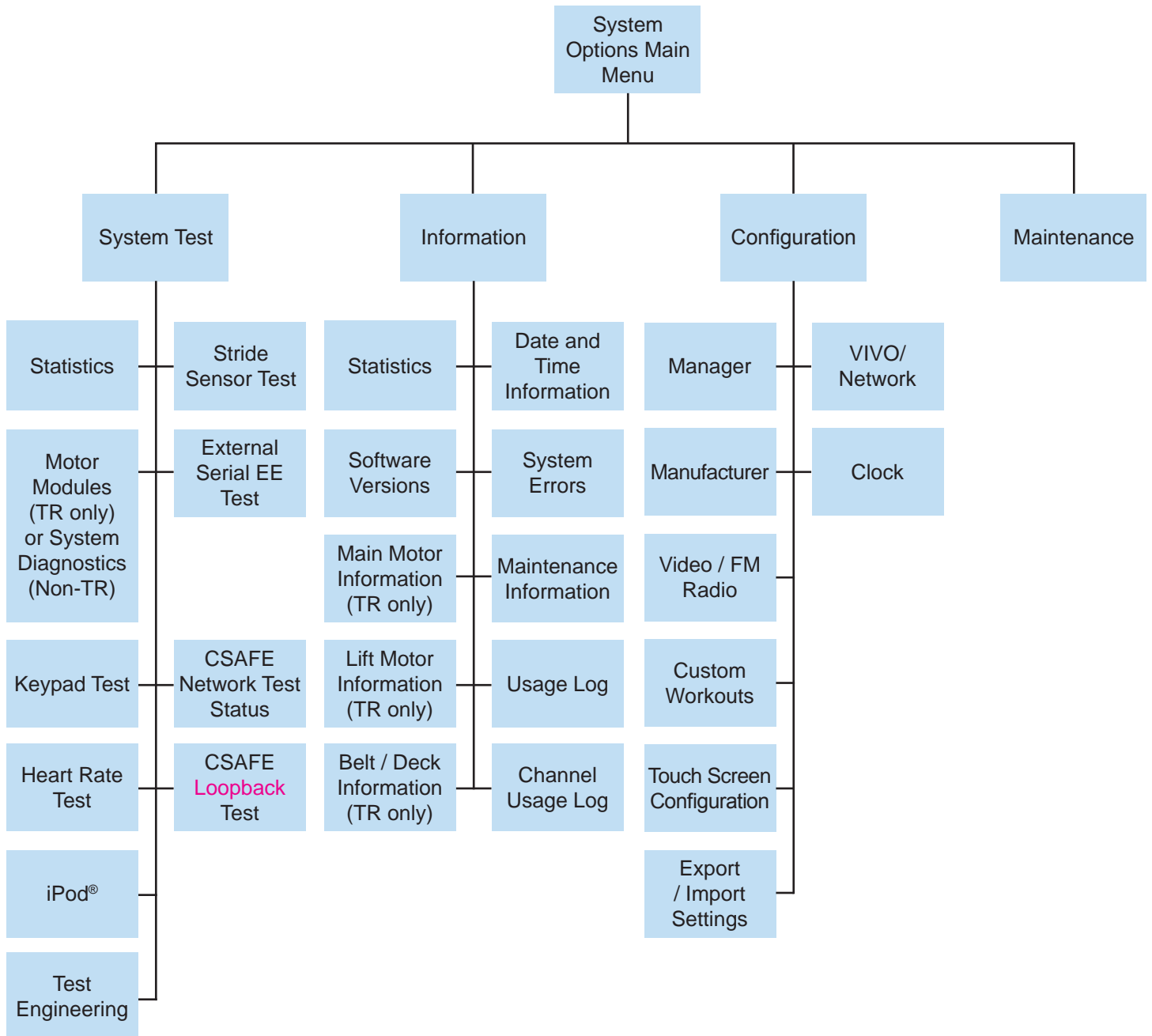

**NOTE:** “TR only” means for Treadmill only. On Bikes and Cross Trainers, those modules marked with “TR only” will not be visible.

## Engage / Inspire Console Diagnostic: System Options - Main Menu

### User Interface

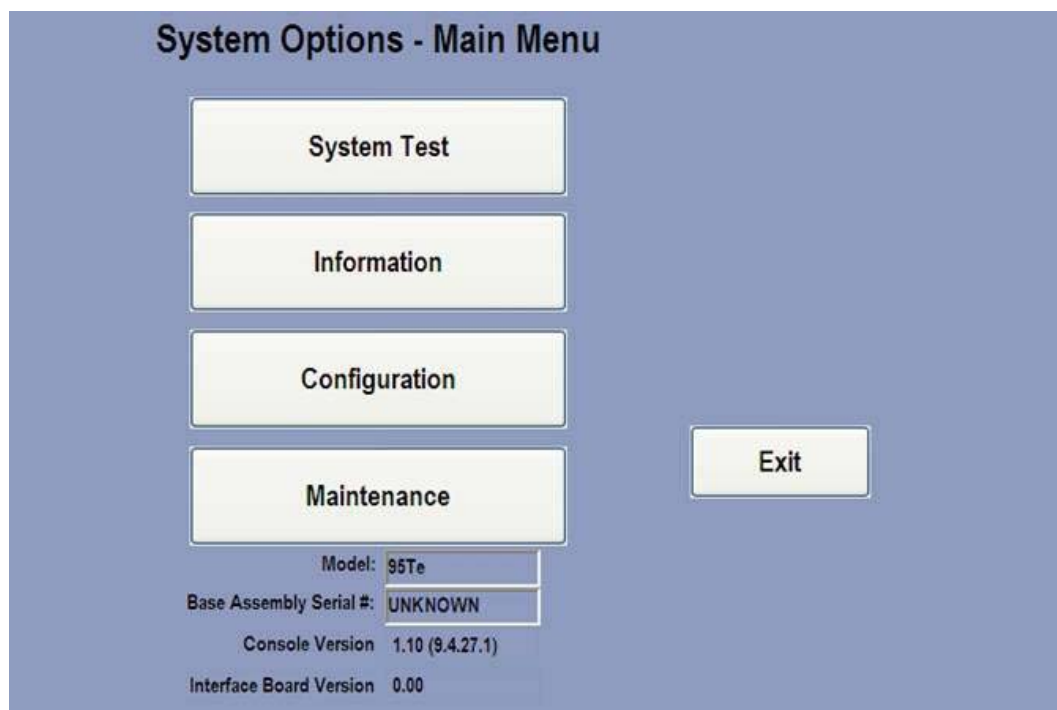

### Object Table

LABEL	DESCRIPTION
System Test Button	Displays the System Test Menu Screen.
Information Button	Displays the Information Menu Screen.
Configuration Button	Displays the Configuration Menu Screen.
Maintenance Button	Displays the Maintenance Screen.
Exit Button	Exits out of the System Options – Main Menu and returns to the Attract Screen.
Readouts	<b>Model:</b> Displays the current model number.
	<b>Base Assembly Serial #:</b> Displays the base assembly serial number.
	<b>Console Version:</b> Displays the current installed console software version number (build number).
	<b>Interface Board Version:</b> Displays the current interface board software version.



## Engage / Inspire Console Diagnostic: System Test Menu 1

### User Interface

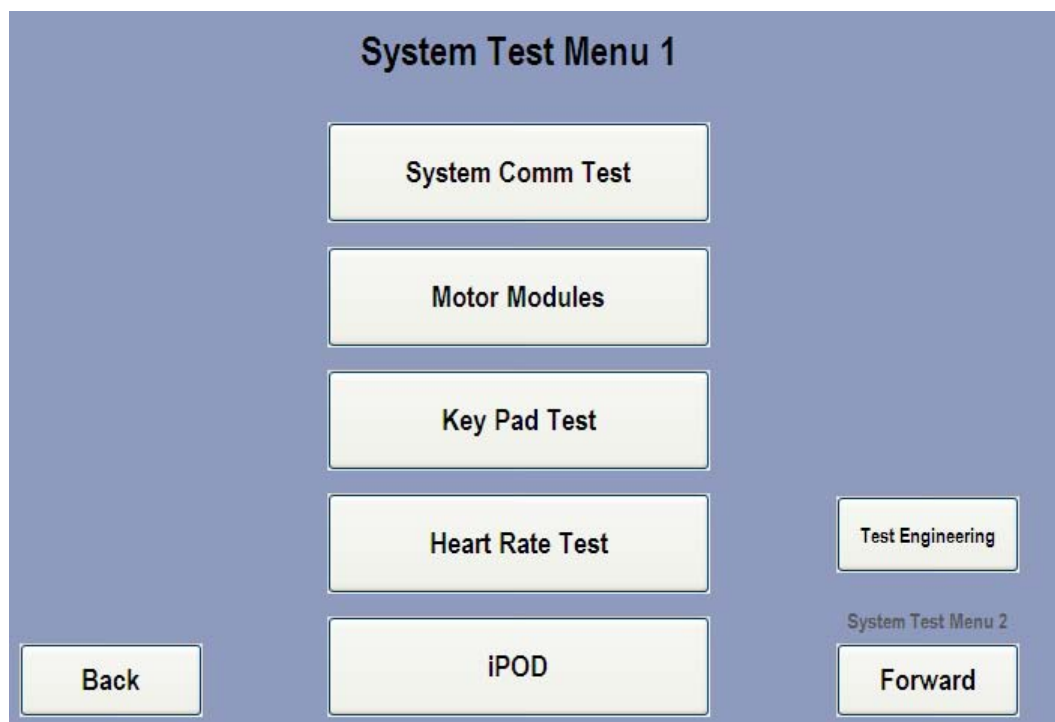

### Object Table

LABEL	DESCRIPTION
System Communication Test Button	Displays System Communication Checks Screen and executes system communication check.
Motor Modules (TR only) or System Diagnostics Button (Non-TR only)	Displays the Motor Modules Screen for TR or System Diagnostic Screen for non- TR.
Key Pad Test Button	Displays the Key Pad Test Screen.
Heart Rate Test Button	Displays the Heart Rate Test Screen.
iPod® Button	Displays the iPod® Test Screen.
Test Engineering Button	Displays the Test Engineering Screen.
Back Button	Displays the previous screen.
Forward Button	Displays the System Test Menu 2 Screen.

## Engage / Inspire Console Diagnostic: System Communication Check

### User Interface

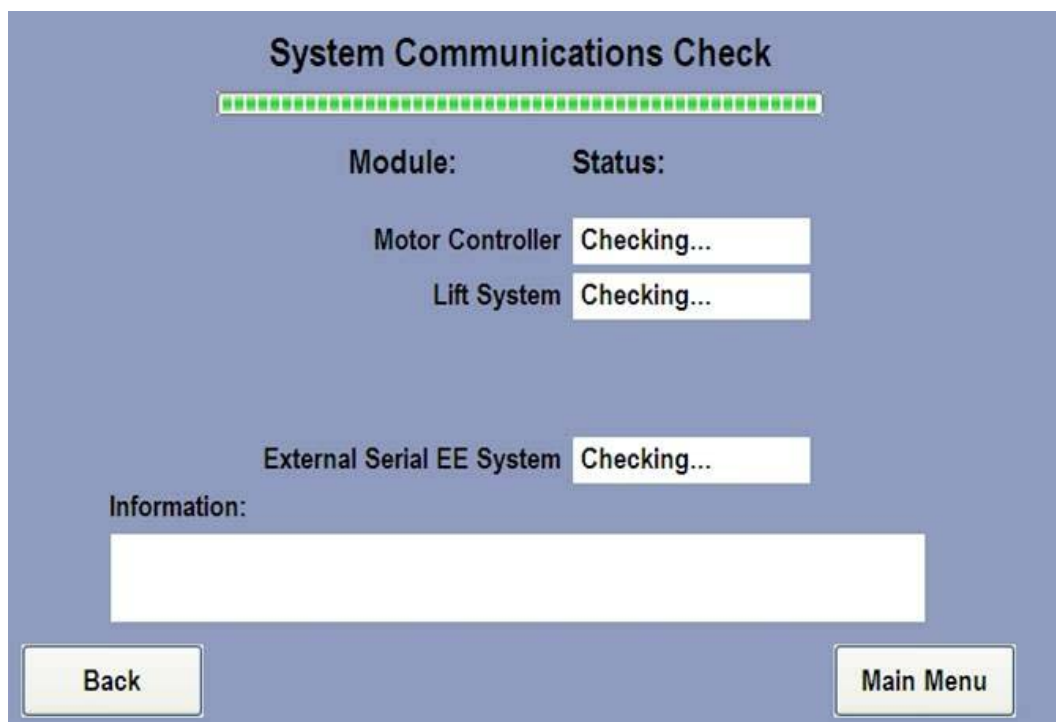

### Object Table

LABEL	DESCRIPTION
Motor Controller	Displays the status of the Motor Controller (i.e. Checking, Detected, Failed)
Lift System	Displays the Motor Modules Screen.
External Serial EE System	Displays the Key Pad Test Screen.
Information	Displays any additional information regarding the System Communication check (i.e. System Communication OK, System Communication Failed, Error - Communication Test Results Not Available).
iPod® Button	Displays the iPod® Test Screen.
Back Button	Displays the previous Screen.
Main Menu Button	Goes back to the System Options – Main Menu

**NOTE:** This test checks the communications between the **MIB** and Motor Controller boards (i.e. System Communication). The Lift System and External Serial EE System are part of the Motor Controller board. To repeat test, press Back button and then System Communication Test button.

# Engage / Inspire Console Diagnostic: Motor Modules (TR Only)

## User Interface

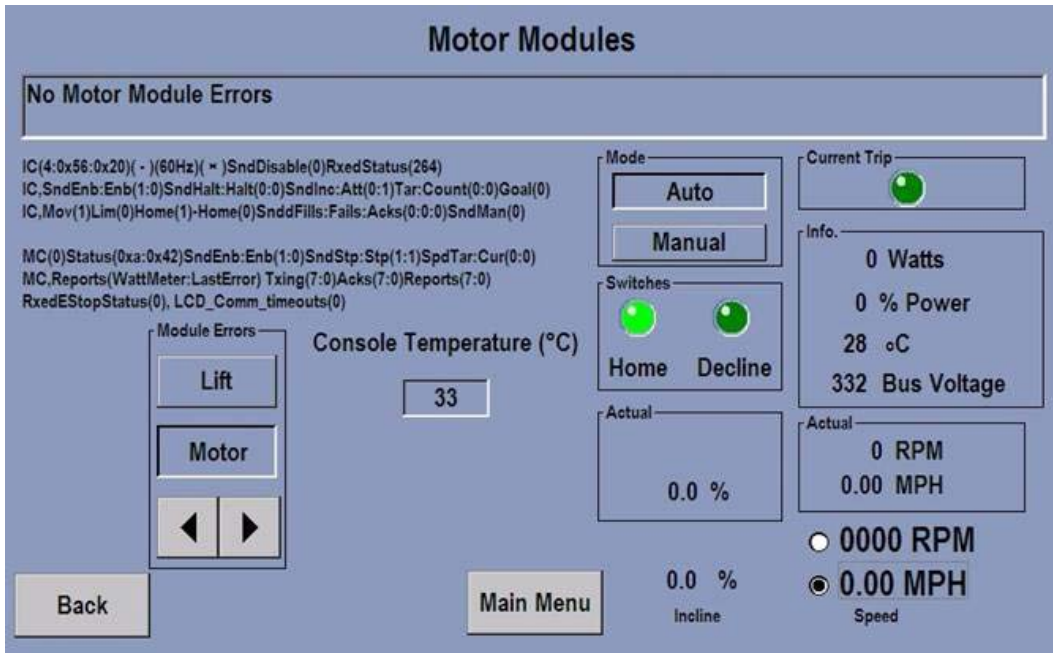

## Object Table

LABEL	DESCRIPTION
Module Errors	<p><b>Lift:</b> Displays module error for incline</p> <p><b>Motor:</b> Displays module error for motor controller</p> <p><b>Note:</b> If there are no errors, the message center reports “No Motor Module Errors”, etc. Only errors occurring in real time are shown here. To see any past errors go to the “System Errors” section.</p>
Mode	<p><b>Auto:</b> Automatically switch the incline (Incline will move and automatically stop at the commanded value as selected using the incline Up/Down keys)</p> <p><b>Manual:</b> Manually adjust the incline up/down (incline moves when either the Incline Up or Down arrow keys are held and stops moving when these keys are released. Note that the incline movements will not stop even if the incline Home Switch (or incline negative switch, if equipped) is encountered.</p>
Console Temperature	Displays the current console temperature.
Actual	<p><b>Actual incline:</b> Displays the current and actual incline percentage.</p> <p><b>Actual RPM and MPH:</b> Displays the current and actual RPM if the RPM radio button is selected or MPH if the MPH radio button is selected.</p>
Current Trip	If lift, then a dynamic or temporary current trip has been detected by the motor controller typically due to an excessive load
Info	<p><b>Watts:</b> Displays the current wattage.</p> <p><b>Power:</b> Displays the current power consumption.</p> <p><b>Temperature:</b> Displays the current temperature of the motor controller board and surrounding area’s.</p> <p><b>Bus Voltage:</b> Displays the current Bus voltage.</p>
Back Button	Goes back to the previous screen.
Main Menu Button	Goes back to the System Options – Main Menu

**NOTE:** The information below the message center is for engineering use and is related to specific communication modules (i.e. “IC” = incline controller, MC = motor controller, etc.)

## Engage / Inspire Console Diagnostic: System Diagnostics Check (Non – TR only)

### User Interface

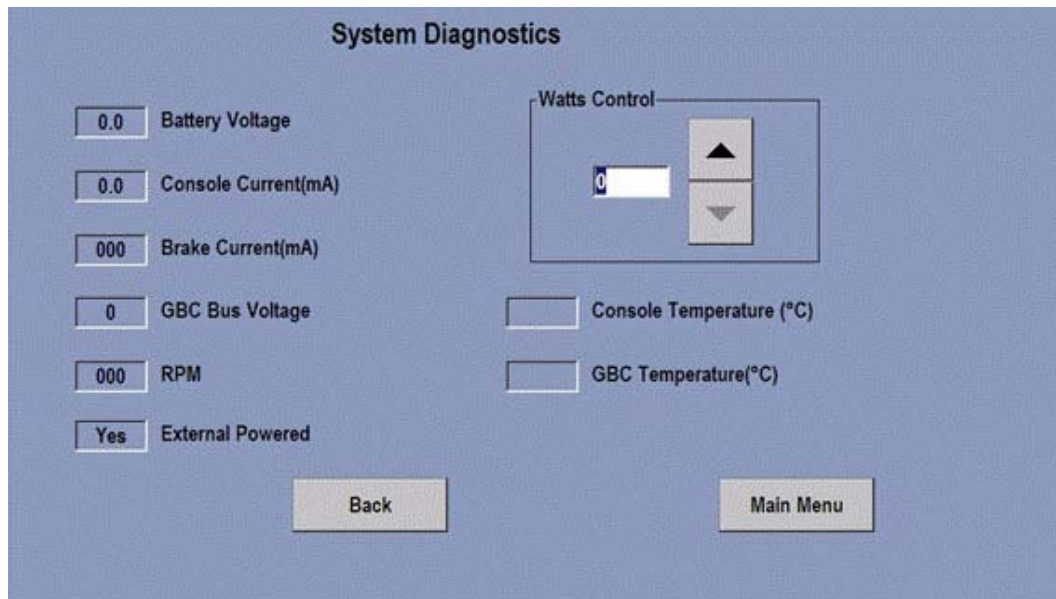

### Object Table

LABEL	DESCRIPTION
Readouts	<b>Battery Voltage:</b> Displays the current battery voltage
	<b>Console Current (mA):</b> Displays the current of the console in milli-amps.
	<b>Brake Current (mA):</b> Displays the break current in milli-amps.
	<b>GBC Bus Voltage:</b> Displays the current voltage of the GBC.
	<b>RPM:</b> Displays the current RPM.
	<b>External Powered:</b> Yes or No
	<b>Console Temperature:</b> Displays the current console temperature in Celcius.
	<b>GBC Temperature:</b> Displays the current GBC temperature in Celcius.
Watts Control	Inputs the amount of Wattage to be tested.
Back	Goes back to the previous screen.
Main Menu Button	Goes back to the System Options – Main Menu.

## Engage / Inspire Console Diagnostic: Key Pad Test

### User Interface

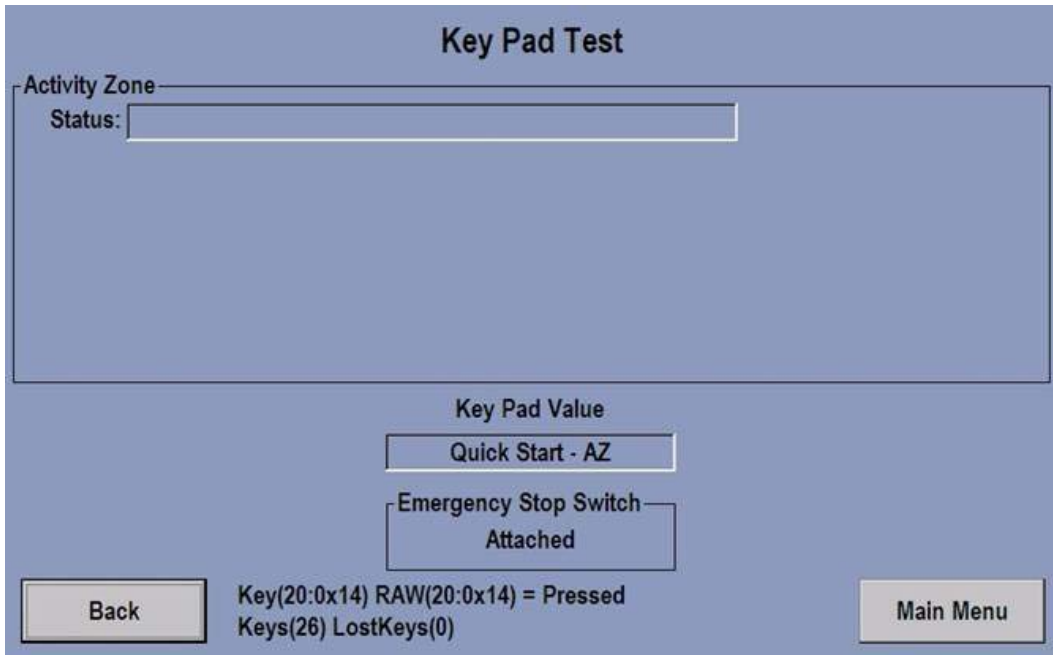

### Object Table

LABEL	DESCRIPTION
Readouts	<b>Activity Zone Status:</b> Displays the Activity Zone keypad status (Detected or Unplugged). When keys are press on this keypad they will shown up in the Key Pad Value area.
	<b>Key Pad Value:</b> Displays the name of the keypad button that is being pressed.
	<b>Emergency Stop Switch:</b> Displays the status of the ESS (i.e. Attached or Not Attached).
Back	Goes back to the previous screen.
Main Menu Button	Goes back to the System Options – Main Menu.

**NOTE:** The additional information at the bottom of the screen is for engineering use and represents communication data between the MIB and SBC concerning hard key press events.

## Engage / Inspire Console Diagnostic: Heart Rate Test

### User Interface

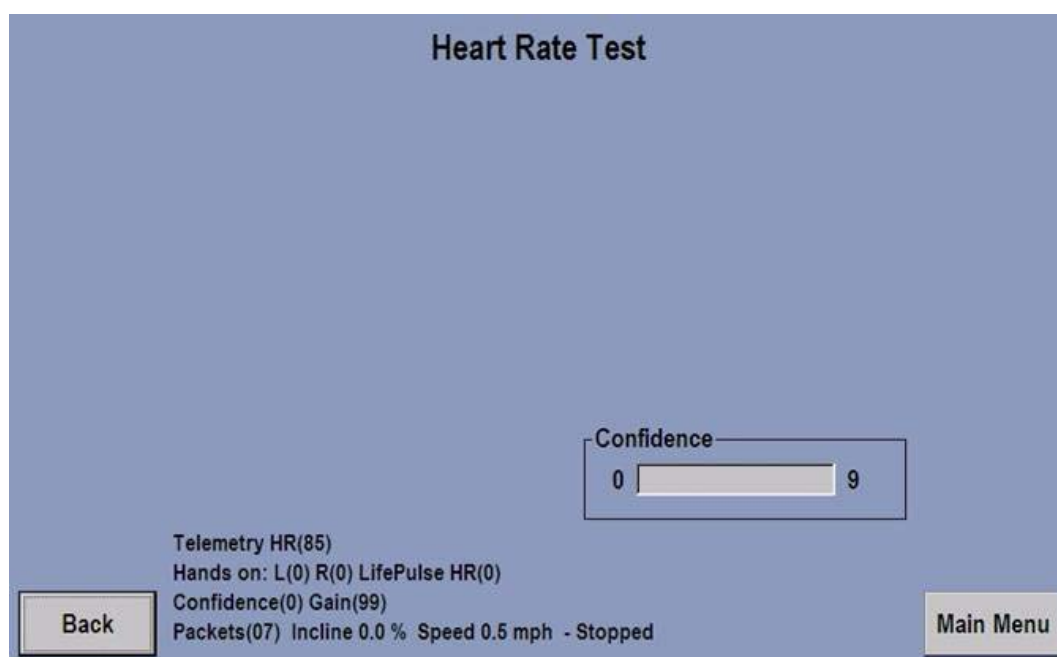

### Object Table

LABEL	DESCRIPTION
Confidence	<b>0-9:</b> Displays the confidence level from 0 – 9 for the heart rate reading on the LifePulse® sensors
Readouts	<b>Telemetry HR:</b> Shows the telemetry strap heart rate reading. If Telemetry(OFF) is shown then telemetry has been disabled in Manager's Configuration.
	<b>Hands on:</b> Shows detection of hands on/off on the left and right Life Pulse sensors. L(0)/R(0) = no hands on detected, L(1)/R(1) = hands on detected.
	<b>LifePulse® HR:</b> Shows the LifePulse® heart rate reading. If LifePulse®(OFF) is shown then Life Pulse has been disabled in Manufacturer's Configuration.
	<b>Confidence:</b> Shows the confidence level of the heart rate detection signal.
	<b>Gain:</b> Shows the amplification level of the Life Pulse heart rate signal. A strong signal results in less required gain. Weaker signals results in a higher gain.
	<b>Packets:</b> Shows the data packet that is being transmitted.
	<b>Incline:</b> Shows the current incline (TR only).
	<b>Speed:</b> Show the current speed.
Back Button	Goes back to the previous screen.
Main Menu Button	Goes back to the System Options – Main Menu.

**NOTE:** You can use the Activity Zone Incline/Speed Up/Down arrow keys to control the belt and incline motors in this test mode.

## Engage / Inspire Console Diagnostic: iPod® Test

### User Interface

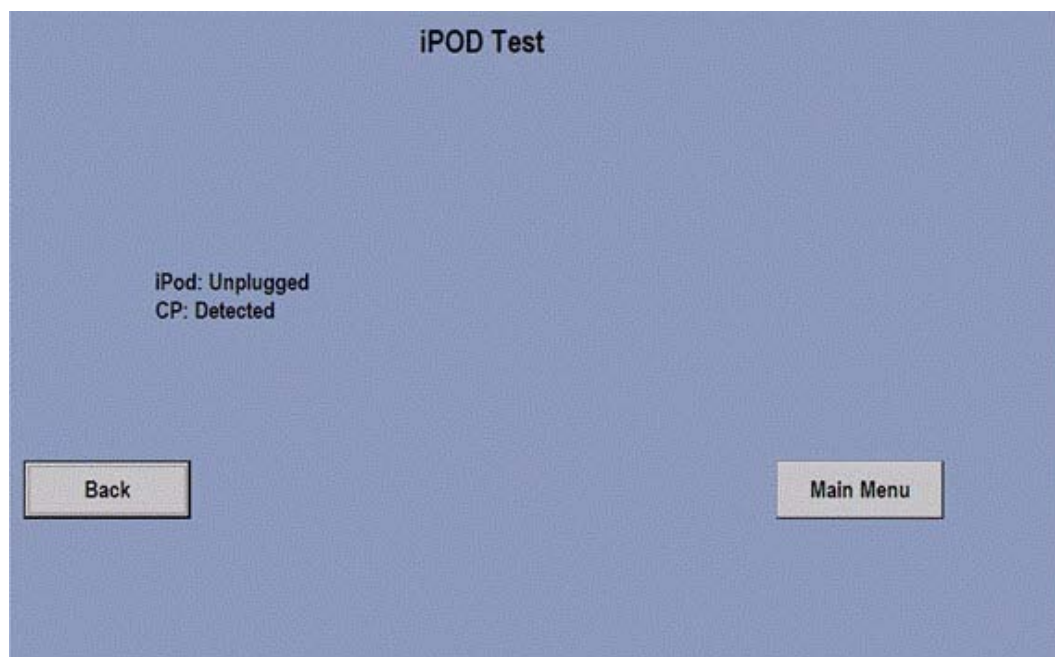

### Object Table

LABEL	DESCRIPTION
Readouts	iPod®: Displays the status of the iPod® (i.e. Unplugged or detected). CP: Displays the status of the co-processor/authentication chip (i.e. detected or not detected).
Back Button	Goes back to the previous screen.
Main Menu Button	Goes back to the System Options – Main Menu.

# Engage / Inspire Console Diagnostic: Test Engineering

## User Interface

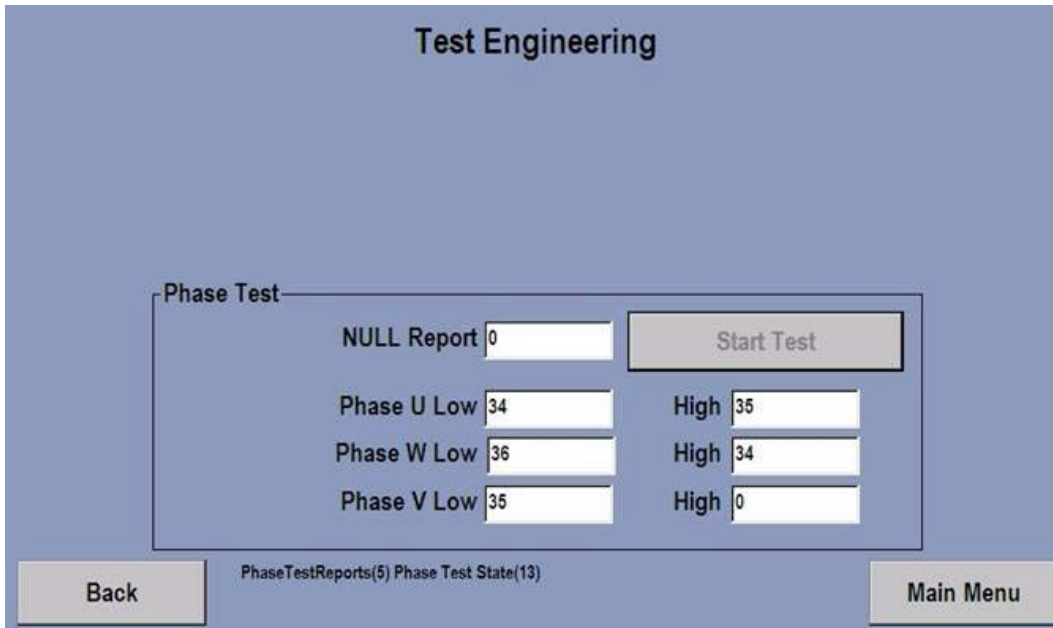

## Object Table

LABEL	DESCRIPTION
Phase Test Readouts	<p><b>NULL Report:</b> Checks the balance of the phases. This value should be <math>\leq 3</math> (0.3a).</p> <p><b>Phase U/W/V Low/High:</b> Checks the individual phases and transistors. These values should be in the 30's (~3a-4a). If one phase pair (Low/High) shows very low, the cable/connector or motor needs to be checked. If individual phase(s) are substantially different, the DSP board needs to be checked.</p>
Start Test Button	Runs the test engineering phase test.
Back Button	Goes back to the previous screen.
Main Menu Button	Goes back to the System Options – Main Menu.



## Engage / Inspire Console Diagnostic: System Test Menu 2

### User Interface

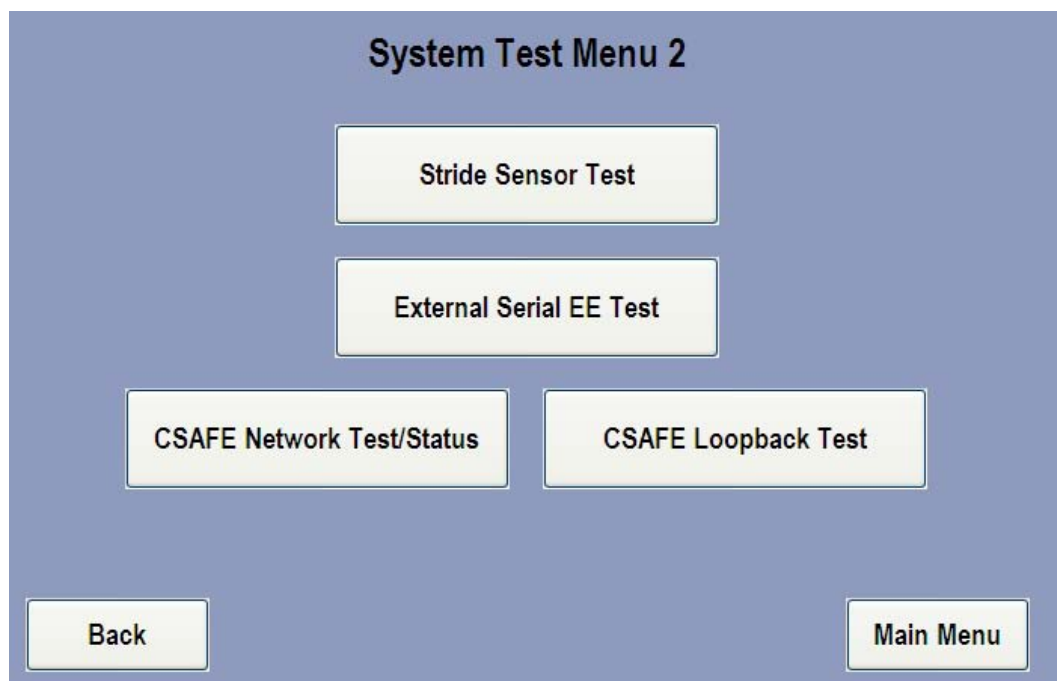

### Object Table

LABEL	DESCRIPTION
Stride Sensor Test Button (TR only)	Displays Stride Sensor Test Screen and executes the stride sensor test (TR only).
External Serial EE Test Button	Displays the External Serial EE Test Screen.
CASFE Network Test / Status Button	Displays CSAFE Network Test / Status Screen and executes the CSAFE Network Test.
CSAFE <b>Loopback</b> Test Button	Displays the CSAFE <b>Loopback</b> Test Screen.
Back Button	Goes back to the previous screen.
Main Menu Button	Goes back to the System Options – Main Menu.

## Engage / Inspire Console Diagnostic: Stride Sensor Test (TR only)

### User Interface

### Object Table

LABEL	SPECIFICATION
User Status	Shows the detection status of a user on the belt (User Detected On Belt or User Not Detected On Belt). Additional status info: "Stride Sensor Disabled" (see Stride Sensor System below) or "Stride Sensor Unplugged". If sensor is detected as unplugged the software will periodically try and re-detect sensor while in this test mode. While re-detecting a "Getting Status..." message will be shown.
Adjust Belt Stop	Trigger point adjustment. Zero = use internal default trigger point (value = 62). When the Average value decays to the trigger point the status will change to "User Not Detected On Belt". Higher Adjust values results in a quicker acting system. A lower value results in taking more time to detect a user has left the belt. Adjusting values that are too low can result in system never detecting that a user has left the belt. Change this adjustment only when recommended to do so.
Stride Sensor System	Allows the Stride Sensor System to be enabled or disabled. When disabled User Status = "Stride Sensor Disabled"
Average	Running average of raw reading (filtered value). When this slower, changing value decays to the trigger point (see Adjust Belt Stop) the User Status changes to "User Not Detected On Belt"
Raw	This is the raw reading from the stride sensor. Reading represents real time actuations of the stride sensor. This is a fast changing value (as opposed to the Average value above). When sensor deflects raw reading jumps to max or close to max. Max = 100.
Readouts	The information in this section is for engineering purposes and represents data being received from the motor controller as well as internal hold off and grace period timers.
Back Button	Goes back to the previous screen.
Main Menu Button	Goes back to the System Options – Main Menu

**NOTE:** You can use the Activity Zone Incline/Speed Up/Down arrow keys to control the belt and incline motors in this test mode.

# Engage / Inspire Console Diagnostic: External Serial EE Test

## User Interface

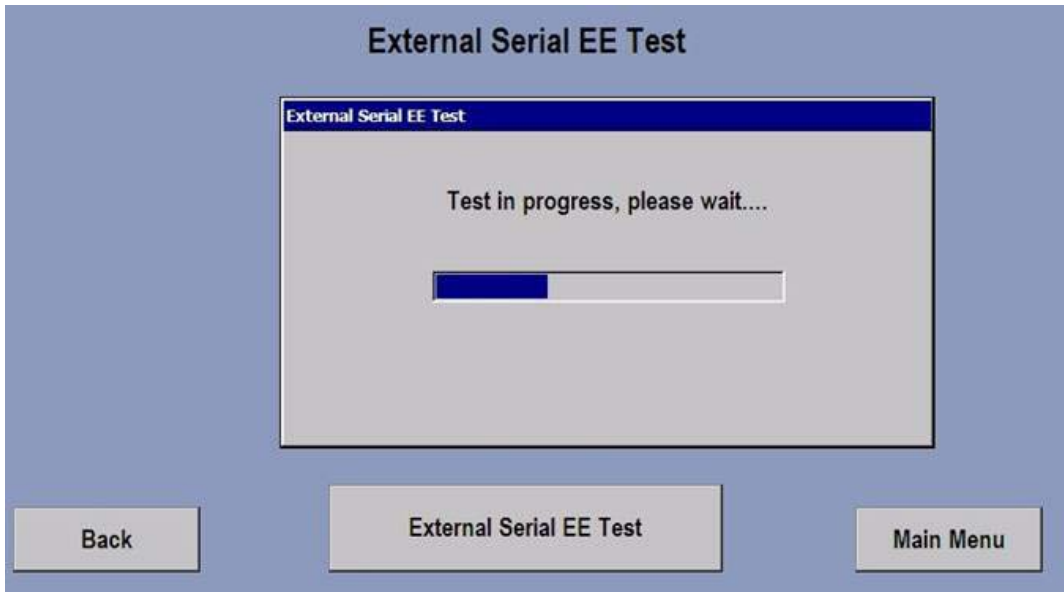

## Object Table

LABEL	SPECIFICATION
External Serial EE Test Button	<p>Executes and displays the test in progress pop-up window.</p> <p>Test result will be displayed in a pop-up with a status of Pass or Failed.</p> <p>This test will verify the proper operation of the serial EE storage chip located on the motor controller which is used to store the Main Motor Info and basic configuration information (product type, etc.).</p>
Back Button	Goes back to the previous screen.
Main Menu Button	Goes back to the System Options – Main Menu.

## Engage / Inspire Console Diagnostic: CSAFE Network Test or Status

### User Interface

**CSAFE Network Test/Status**

Information	Configuration	CSAFE Version
Rx Packets: 0	ID Length: 5	Manufacturer: 9
Tx Packets: 1	Timeout Period(Seconds): 15	CID: 2
Timeout Timer(Seconds):	Up-List(# Items): 0	Model: 23
CSAFE State: READY		Version: 11
Previous Rejects: 0		Release: 10
Previous Bads: 0		
Net Down Timer(Seconds):		

Reset Connection

Back Main Menu

### Object Table

LABEL	SPECIFICATION
Information Readouts	<b>Rx Packets:</b> Displays the number of data packets received.
	<b>Tx Packets:</b> Displays the number of data packets transmitted.
	<b>Timeout Timer:</b> Displays the timeout in seconds.
	<b>CSAFE State:</b> Displays the current state of the CSAFE network.
	<b>Previous Bads:</b> Displays the number of bad requests
	<b>Net Down Timer:</b> Displays the down time of the network in seconds.
Configuration Readouts	<b>ID Length:</b> Displays the ID length number.
	<b>Timeout Period:</b> Displays the timeout in seconds.
	<b>Up-List:</b> Displays the number of up-list items.
CSAFE Version Readouts	<b>Manufacturer:</b> Displays the manufacturer's ID number.
	<b>CID:</b> Displays the connection ID number.
	<b>Model:</b> Displays the model number.
	<b>Version:</b> Displays the version number.
	<b>Release:</b> Displays the release number
Reset Connection Button	Resets the connection to the CSAFE network.
Back Button	Goes back to the previous screen.
Main Menu Button	Goes back to the System Options – Main Menu.

**NOTE:** This test shows many CSAFE communication specification parameters and is intended to provide more detailed information for engineering and third party companies that make compatible CSAFE devices. Use the "CSAFE **Loopback** Test" to test the console's CSAFE port.

## Engage / Inspire Console Diagnostic: CSAFE Loopback Test

### User Interface

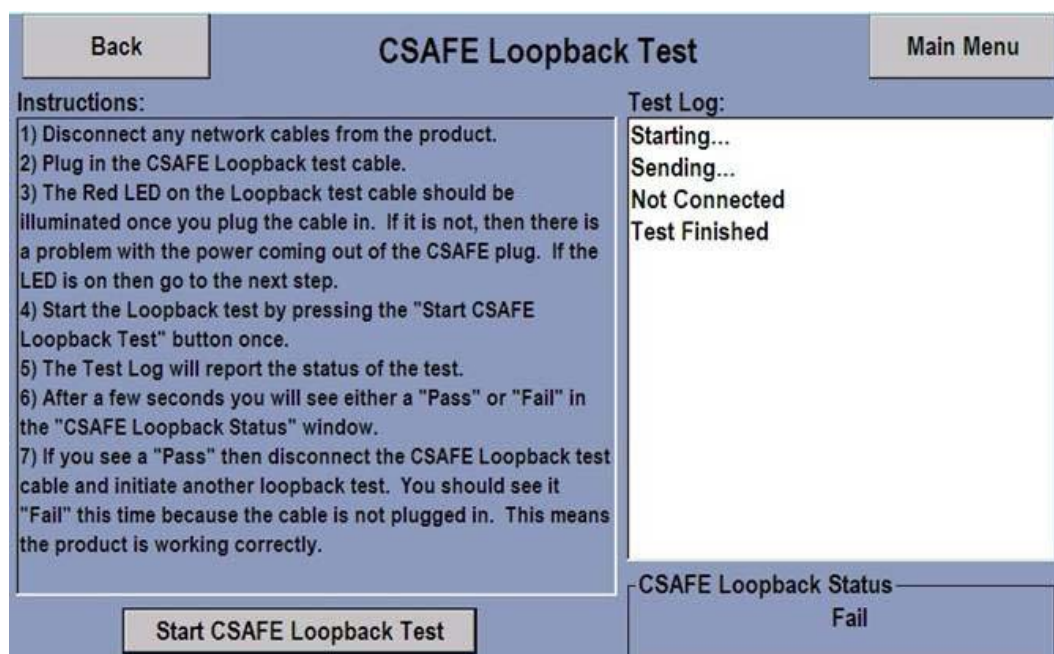

### Object Table

LABEL	SPECIFICATION
Instructions	Displays the seven steps instructions to perform the CSAFE Loopback Test.
Test Log	Displays and logs the status of all the testing steps and results.
CSAFE Loopback Status	Displays the status of the loopback test (i.e. Pass or Fail).
Back Button	Goes back to the previous screen.
Main Menu Button	Goes back to the System Options – Main Menu.

**NOTE:** This test is used to verify the console's CSAFE port and to provide instructions on how to use and diagnose port problems.

## Engage / Inspire Console Diagnostic: Information Menu

### User Interface

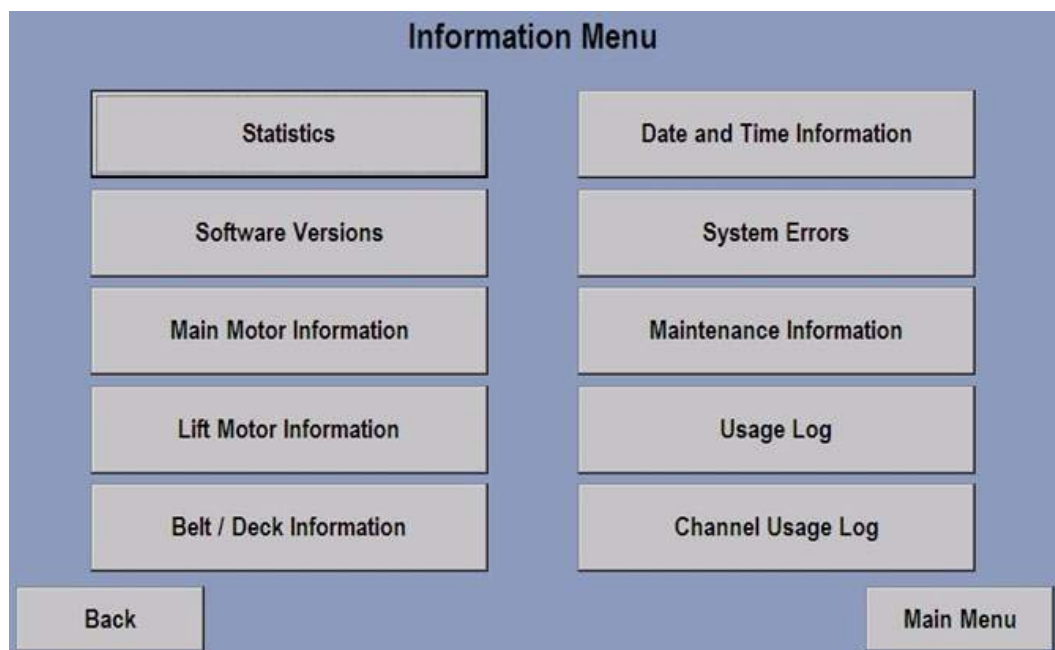

### Object Table

LABEL	DESCRIPTION
Statistics Button	Displays the Information Statistics Screen.
Software Versions Button	Displays the Software Versions Screen.
Main Motor Information Button	Displays the Main Motor Information Screen.
Lift Motor Information Button	Displays the Lift Motor Information Screen.
Belt / Deck Information Button	Displays the Belt / Deck Information Screen.
Date and Time Information Button	Displays the System Date and Time Information Screen.
System Errors Button	Displays the System Errors Screen.
Maintenance Information Button	Displays the Maintenance Information Screen.
Usage Log Button	Displays the Usage Log Report Screen.
Channel Usage Log Button	Displays the TV Channel Usage Log Screen.
Back Button	Goes back to the previous screen.
Main Menu Button	Goes back to the System Options – Main Menu.

## Engage / Inspire Console Diagnostic: Information Statistics

### User Interface

The screenshot displays the 'Information Statistics' screen with the following data:

Category	Value
POWER-UP COUNT	22
TOTAL HOURS	20:43:00
TOTAL MILES	9.98
BELT HOURS	20:43:00
BELT MILES	9.98
LIFT HOURS	0:02:46
CHANGE WORKOUTS	3
QUICK	48
MANUAL	10
HILL	0
RANDOM	3
FAT BURN	2
PRESET COUNT	4
Nike + iPod Accepted	0
CARDIO	0
HR HILL	0
HR INTERVAL	0
EXTREME HR	0
SPEED INTERVAL	1
SPORT TRAINING 5K	0
SPORT TRAINING 10K	0
SPORT TRAINING	0
LF FIT TEST	11
GERKIN	1
PEB	1
Nike + iPod Rejected	0
WORKOUT COUNT	85
ARMY	1
NAVY PRT	1
MARINE	0
AIR FORCE	1
NETWORKED	0
CUSTOM	1
TIME GOALS	66
DISTANCE GOALS	3
CALORIES GOALS	0
TIME-IN-ZONE GOALS	0
MARATHON MODE	0
VIDEO	10

Navigation buttons: Back, Export To USB, Main Menu.

### Object Table

LABEL	DESCRIPTION
Information Readouts	<b>POWER-UP COUNT:</b> Shows many times the system has been powered-up.
	<b>TOTAL HOURS:</b> Shows the total hours of machine usage.
	<b>TOTAL MILES:</b> Shows the total miles accumulated for the machine.
	<b>BELT HOURS:</b> Shows the total number of hours accumulated for the belt usage.
	<b>BELT MILES:</b> Shows the total number of miles accumulated for the belt usage.
	<b>LIFT HOURS:</b> Shows the total number of hours of up incline operations.
	<b>CHANGE WORKOUTS:</b> Show the total number of times this feature was invoked.
	<b>QUICK:</b> Shows the total number of times this program (Quick Start) was invoked.
	<b>MANUAL:</b> Shows the total number of times this program was invoked.
	<b>HILL:</b> Shows the total number of time this program was invoked.
	<b>RANDOM:</b> Shows the total number of times this program was invoked.
	<b>FAT BURN:</b> Shows the total number of times this program was invoked.
	<b>PRESET COUNT:</b> Shows the total number of times this program was invoked.
	<b>Nike + iPod® Accepted:</b> Shows the total number of times this feature was accepted.
	<b>CARDIO:</b> Shows the total number of times this program was invoked.
	<b>HR HILL:</b> Shows the total number of times this program was invoked.
	<b>HR INTERVAL:</b> Shows the total number of times this program was invoked.
<b>EXTREME HR:</b> Shows the total number of times this program was invoked.	
<b>SPEED INTERVAL:</b> Shows the total number of times this program was invoked.	

## Information Statistics

### Object Table

LABEL	DESCRIPTION
Information Readouts	<b>SPORT TRAINING 5K:</b> Shows the total number of times this program was invoked.
	<b>SPORT TRAINING 10K:</b> Shows the total number of times this program was invoked.
	<b>SPORT TRAINING:</b> Shows the total number of times this program was invoked.
	<b>LF FIT TEST:</b> Shows the total number of times this program was invoked.
	<b>GERKIN:</b> Shows the total number of times this program was invoked.
	<b>Nike + iPod® Rejected:</b> Shows the total number of times this feature was rejected.
	<b>WORKOUT COUNT:</b> Shows the total number of times this program was invoked.
	<b>ARMY:</b> Shows the total number of times this program was invoked.
	<b>NAVY PRT:</b> Shows the total number of times this program was invoked.
	<b>MARINE:</b> Shows the total number of times this program was invoked.
	<b>AIR FORCE:</b> Shows the total number of times this program was invoked.
	<b>NETWORKED:</b> Shows the total number of times a network workout program was invoked.
	<b>CUSTOM:</b> Shows the total number of times this program was invoked.
	<b>TIME GOALS:</b> Shows the total number of times this feature was invoked.
	<b>DISTANCE GOALS:</b> Shows the total number of times this feature was invoked.
	<b>CALORIES GOALS:</b> Shows the total number of times this feature was invoked.
<b>TIME-IN-ZONE GOALS:</b> Shows the total number of times this feature was invoked.	
<b>MARATHON MODE:</b> Shows the total number of times this feature was invoked.	
<b>VIDEO:</b> Shows the total number of times this feature was invoked.	
Export to USB Button	Export all the information on the screen to a USB stick in a .CSV (comma separated value) file.
Back Button	Goes back to the previous screen.
Main Menu Button	Goes back to the System Options – Main Menu.



## Engage / Inspire Console Diagnostic: Software Versions

### User Interface

**Software Versions**

Base Assembly Serial #: 111-111111

Console Serial #: UNKNOWN

Console Version: 1.10      Part #: K70N-12603-0000

Motor Version: 52.00      Serial #: 92343-C000B-08200016

LifePulse Version: 9.9

CSAFE Version: 23.11.11

Interface Boot Version: 3

Interface Board Version: 3.20      Part #: K70O-12601-0000

Console Boot Version: 2.11

Apploader Version: 1.7.7.27

Media Manager Version: 9.4.15.1

TREADMILL (Apr 15 2009 - 16:34:13)  
WinCE Version: 5.00.21 LIFE\_FITNESS\_E

Back      Export To USB      Main Menu

### Object Table

LABEL	DESCRIPTION
Readouts	<b>Base Assembly Serial #:</b> Displays the base assembly serial number.
	<b>Console Serial #:</b> Displays the console serial number.
	<b>Console Version / Part #:</b> Displays the software version number and part number.
	<b>Motor Version / Serial #:</b> Displays the software version number and part number.
	<b>LifePulse® Version:</b> Displays the software version number.
	<b>CSAFE Version:</b> Displays the software version number.
	<b>Interface Boot Version:</b> Displays the software version number.
	<b>Interface Board Version / Part #:</b> Displays the software version number and part number.
	<b>Console Boot Version:</b> Displays the software version number.
	<b>Apploader Version:</b> Displays the software version number.
	<b>Media Manager Version:</b> Displays the software version number.
	<b>Treadmill/Bike/CT:</b> Date and time of the console software build
	<b>WinCE Version:</b> Displays the version number of the Windows CE operating system.
Export to USB Button	Export all the information on the screen to a USB stick in a .CSV (comma separated value) file.
Back Button	Goes back to the previous screen.
Main Menu Button	Goes back to the System Options – Main Menu.

# Engage / Inspire Console Diagnostic: Main Motor Information (TR Only)

## User Interface

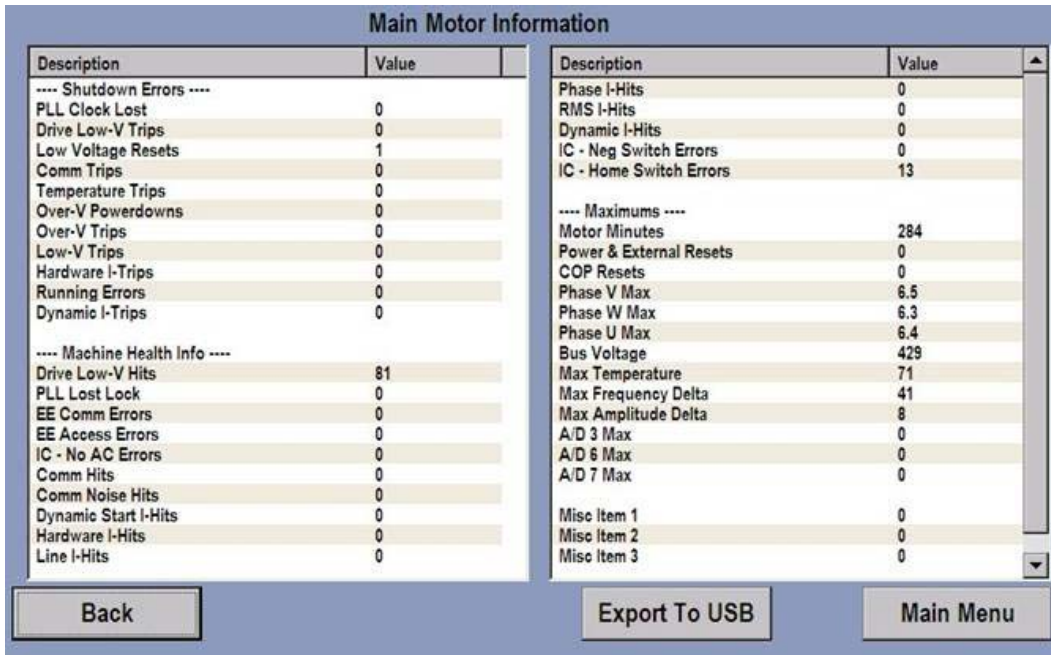

## Object Table

LABEL	DESCRIPTION
Readouts	Description and Value: Display shutdown errors, health, power, and voltage information.
Export To USB Button	Export all the information on the screen to a USB stick in a .CSV (comma separated value) file.
Back Button	Goes back to the previous screen.
Main Menu Button	Goes back to the System Options – Main Menu.

## Shutdown Errors

Shutdown Errors records events that caused the motor to stop and report an error to the console.

Machine Health Info records events that have not stopped the motor that the system recovered from, but may be an indication of a potential problem in the future.

Maximums show monitored signal extremes and may be useful in diagnosing problems.

When analyzing the Main Motor Information keep in mind that a Shutdown Error actually caused the belt to stop in a safe manner but nonetheless (and most likely) when a user was on it. Low value Machine Health Info counts in general are not a concern but combinations of them can help determine a machines' condition, i.e. any type of I-Hit combined with high maximum phase currents (>10a) can be an indication of a worn belt.

## Engage / Inspire Console Diagnostic: Main Motor Information (TR Only)

### Shutdown Errors

Shutdown Errors records events that caused the motor to stop and report an error to the console.

Machine Health Info records events that have not stopped the motor that the system recovered from but may be an indication of a potential problem in the future.

Maximums show monitored signal extremes and may be useful in diagnosing problems.

When analyzing the Main Motor Information keep in mind that a Shutdown Error actually caused the belt to stop in a safe manner but nonetheless most likely when a user was on it. Low value Machine Health Info counts in general are not a concern but combinations of them can help determine a machines' condition, i.e. any type of I-Hit combined with high maximum phase currents (>10a) can be an indication of a worn belt.

LABEL	DESCRIPTION
PLL Clock Lost	<p>If the phase locked loop circuitry detects no clock, this error will occur. If the motor is running and this occurs the motor stops quickly, turning off the drive. The state of the phase lock is monitored every 75us.</p> <p><b>CAUSE</b> Noisy system or defective DSP board.</p> <p><b>ACTION</b> Check all grounds and cables first. If the number is &gt;3 the DSP board should be checked.</p>
Drive Low-V Trips	Not Used.
Low Voltage Resets	<p>The processor has detected a voltage &lt; 2.7v to the processor but it hasn't shut down. If the motor is running and this occurs the motor stops immediately, turning off the drive.</p> <p><b>CAUSE</b> Power line surges or an intermittent line cord or wall outlet.</p> <p><b>ACTION</b> Check the power source and line cord. Same action as "Low-V Trips" below.</p>
Communication Trips	<p>If the motor controller stops receiving transmissions from the console for more than 5 seconds, the motor will come to a stop at its normal rate. The incline will be held at its present position.</p> <p><b>CAUSE</b> Vibration can cause the connection to become intermittent and disrupt communication between the console and M/C.</p> <p><b>ACTION</b> Check the console cable and connectors. Make sure they are fully seated. Observe communication LED #3. It should be flashing at a very high rate (~5/sec). If you wiggle the cable around and the flashing is changed or even stopped, there is a strong indication that the cable is the problem.</p>

## Engage / Inspire Console Diagnostic: Main Motor Information (TR Only)

LABEL	DESCRIPTION
Temperature Trips	<p>If the current limit reduction scheme fails to control the module temperature, 100c an over-temperature trip will occur at 100C. The motor will come to a stop at its normal rate.</p> <p><b>CAUSE</b></p> <ul style="list-style-type: none"> <li>• Airflow restriction into the motor compartment caused by blockage or lint buildup. The unit is located over a heating vent and hot air is being blown into it.</li> <li>• Direct sunlight on the unit can cause this effect although to a lesser degree.</li> <li>• A severely worn belt.</li> </ul> <p><b>ACTION</b></p> <p>Clean in and around the compartment and insure the above conditions are not occurring.</p>
Over-V Powerdowns	<p>If the bus voltage is over 460v and the motor is running, this mode will disengage the motor by gradually removing the drive voltage over a period of approximately a second, depending on its present excitation level. This is the final measure to prevent over-voltage on the bus capacitors.</p> <p><b>CAUSE</b></p> <p>Users actively pushing the belt at running speeds and maximum incline can overcome the friction of the belt/deck sufficiently to deliver power into the system.</p> <p><b>ACTION</b></p> <p>Observe if this is actually happening and if so recommend that the user uses a lower incline with possibly a higher speed.</p>
Over-V Trips	<p>If the bus voltage is over 460v this error will be detected. If the motor is running the system will go into Overvoltage Powerdown Mode (above). Otherwise the power relay will be opened immediately.</p> <p><b>CAUSE</b></p> <p>As described above (if the user pushes the belt) as well as any power line issue.</p> <p><b>ACTION</b></p> <p>If users are not pushing the belt the power line needs to be monitored for dramatically poor voltage regulation.</p>
Low-V Trips	<p>If the bus voltage is lower than the 190v limit when the relay is closed and ESS switch is on an, error condition will be tripped. The power relay will be opened and the motor will be disabled, forcing it to a controlled stop.</p> <p><b>CAUSE</b></p> <p>The bus voltage has dropped below its minimum operating value.</p> <p><b>ACTION</b></p> <p>An improperly seated power cord or badly installed outlet (loose screws holding the wires) will cause the voltage to momentarily sag triggering this error. Insure that the product is directly connected to a dedicated circuit. Using an extension cord can cause this error.</p>

## Engage / Inspire Console Diagnostic: Main Motor Information (TR Only)

LABEL	DESCRIPTION
Hardware I-Trips	<p>The hardware overcurrent limit has been hit consistently for over 250ms, which caused a motor shutdown.</p> <p><b>CAUSE</b> Persistent, excessive motor current over 24a will cause this trip.</p> <p><b>ACTION</b> Check that the motor wiring is not being shorted. Check that the motor plug and all its wires are seated properly and that there is no contamination on the pins. Run the phase test to isolate a troubled phase(s).</p>
Running Errors	<p>If after four seconds the motor hasn't drawn over 1a motor current this error will be tripped. The motor will be disabled forcing it to a controlled removal of the motor voltage.</p> <p><b>CAUSE</b> An unplugged motor cable or damaged motor.</p> <p><b>ACTION</b> Make sure the motor is properly plugged in, then run the phase test.</p>
Dynamic I-Trips	<p>Excessive motor or line current has been detected. An appropriate motor rpm drop will be commanded to try to keep the current within its limit. In this case the motor slowed down to a point where it actually went into a pause state.</p> <p><b>CAUSE</b> Excessive belt and deck wear or very high user weight at high speeds.</p> <p><b>ACTION</b> Check the belt/deck and replace if worn.</p>

## Engage / Inspire Console Diagnostic: Main Motor Information (TR Only)

### Machine Health Info

LABEL	DESCRIPTION
Drive Low-V Hits	<p>This mechanism, which detects low power supply voltage to the power driver chip, had a hit.</p> <p><b>CAUSE</b> Power cycling and occasionally noise induced.</p> <p><b>ACTION</b> This event is recorded only; no action is taken by the DSP. If <b>many</b> are present (&gt;25) the grounds and cables should be checked.</p>
PLL Lost Lock	<p>If the phase locked loop circuitry detects a mismatch in desired speed this hit will occur. It will only be recorded. The state of the phase lock is also monitored every 75us.</p> <p><b>CAUSE</b> Because of noise and other disturbances the clock may vary slightly in speed. No noticeable affects will be felt by the user.</p> <p><b>ACTION</b> No action is required if the number is relatively low (&lt;25). If many, then grounds should be checked, followed by a check of the DSP.</p>
EE Communication Errors	<p>The processor is unable to communicate with the EEPROM.</p> <p><b>CAUSE</b> A damaged DSP board or EEPROM chip.</p> <p><b>ACTION</b> If occurrences are high (&gt;10) replace the DSP board or run as it is. Console will not be able to save data if the DSP is faulty.</p>
EE Access Errors	<p>A write to the EEPROM was not acknowledged in 30ms or a write verify failed.</p> <p><b>CAUSE</b></p> <ul style="list-style-type: none"> <li>• Power removed while writing to EEPROM.</li> <li>• A damaged DSP board or EEPROM chip.</li> </ul> <p><b>ACTION</b> If occurrences are high (&gt;10) replace the DSP board or run as it is. Console will not be able to save data if the DSP is faulty.</p>
IC - No AC Errors	<p>The frequency detection circuitry did not detect 60hz or 50hz. The incline will still operate however using the default parameters for 60hz.</p> <p><b>CAUSE</b> Power cycling or a damaged DSP board.</p> <p><b>ACTION</b> If occurrences are high (&gt;10) check the DSP board.</p>

## Engage / Inspire Console Diagnostic: Main Motor Information (TR Only)

LABEL	DESCRIPTION
Communication Hits	<p>The receive module of the DSP detected an error in a data packet. This packet will be discarded but the system will continue to function.</p> <p><b>CAUSE</b> A damaged or intermittent console cable can cause these. A few of these are normal because of occasional power sequencing differences or drive and incline motor noise.</p> <p><b>ACTION</b> Check the console cable and wiring. Make sure all grounds are solid.</p>
Communication Noise Hits	<p>The receive module of the DSP detected noise on the communication line. If the noise did not cause a checksum error, everything continued normally. If it did then the packet was discarded but the system continued to function.</p> <p><b>CAUSE</b> A less severe case than above but with the same causes.</p> <p><b>ACTION</b> Check the console cable and wiring. Make sure all grounds are solid.</p>
Dynamic Start I-Hits	<p>Excessive motor current has been detected while the motor is starting. An appropriate motor rpm drop will be commanded to try to keep the current within its limit. The DSP will continue monitoring the condition for four seconds. If the excessive current is not reduced to an acceptable level, the motor will stop.</p> <p><b>CAUSE</b> A stalled belt condition, possibly being the result of a worn belt/deck.</p> <p><b>ACTION</b> Check for an excessively worn belt/deck.</p>
Hardware I-Hits	<p>A hardware current limit occurred. No software action occurs other than recording the event a maximum of once every 250ms. The hardware limits the current on a cycle by cycle basis.</p> <p><b>CAUSE</b> An excessive motor current over 24a will cause this hit.</p> <p><b>ACTION</b> As in the above "Hardware I-Trips" condition, check that the motor wiring is not being shorted. Check that the motor plug and all its wires are seated properly and that there is no contamination on the pins. Run the phase test to isolate a troubled phase(s).</p>
Line I-Hits	<p>The line current exceeded the allowable limit. An appropriate motor rpm drop will be commanded to try to keep the current within its limit.</p> <p><b>CAUSE</b> Excessive motor current draw caused by a bad belt/deck or a high user weight combined with a high speed.</p> <p><b>ACTION</b> Check for an excessively worn belt/deck.</p>

## Engage / Inspire Console Diagnostic: Main Motor Information (TR Only)

LABEL	DESCRIPTION
Phase I-Hits	<p>The largest individual peak phase current has exceeded 17a; this is relatively quick limit. An appropriate motor rpm drop will be commanded to try to keep the current within its limit.</p> <p><b>CAUSE</b> Users intentionally stomping on the belt can cause these and are considered normal. Excessive motor current draw caused by a bad belt/deck or a high user weight combined with a high speed.</p> <p><b>ACTION</b> Check for an excessively worn belt/deck.</p>
RMS I-Hits	<p>The effective maximum rms current of the motor has exceeded 21.3a. An appropriate motor rpm drop will be commanded to try to keep the current within its limit.</p> <p><b>CAUSE</b> Excessive motor current draw caused by a bad belt/deck or a high user weight combined with a high speed.</p> <p><b>ACTION</b> Check for an excessively worn belt/deck.</p>
Dynamic I-Hits	<p>One of the above occurred:</p> <p>Line I-Hits</p> <p>Phase I-Hits</p> <p>RMS I-Hits</p>
IC – Neg Switch Errors	<p>The negative switch logic reported an error. Because of noise and thermal trips, a few occurrences are acceptable.</p> <p><b>CAUSE</b> An invalid combination of incline switch states occurred, or a timeout occurred going to or away from the negative switch.</p> <p><b>ACTION</b> If a substantial amount (&gt;9) of these are recorded, the negative switch and associated wiring should be checked.</p>
IC – Home Switch Errors	<p>The Home Switch logic reported an error. Because of noise and thermal trips, a few occurrences are acceptable.</p> <p><b>CAUSE</b> An invalid combination of incline switch states occurred or a timeout occurred going to or away from the Home Switch.</p> <p><b>ACTION</b> If a substantial amount (&gt;9) of these are recorded, the Home Switch and associated wiring should be checked.</p>



## Engage / Inspire Console Diagnostic: Main Motor Information (TR Only)

### Maximums

LABEL	DESCRIPTION
Motor Minutes	Motor running time in minutes.
Power & External Resets	How many times the DSP has gone through a reset operation.
COP Resets	The internal "computer operating properly" watchdog timer detected an abnormal condition and caused the system to reset. This can only occur when reprogramming a board or testing at the factory. Only a <b>few</b> (<5) should ever be seen.
Phase V Max	The highest magnitude peak current measured in phase V.
Phase W Max	The highest magnitude peak current measured in phase W.
Phase U Max	The highest magnitude peak current measured in phase U.  NOTE: The above three should always be approximately the same within approximately 1a. If not the motor phase wiring and connectors should be checked.
Bus Voltage	The highest voltage measured on the bus. Anything over 400v is a possible indication of users driving the belt at higher incline and higher speed.
Max Frequency Delta Max Amplitude Delta A/D 3 Max A/D 6 Max A/D 7 Max Misc Item 1 Misc Item 2 Misc Item 3	These are diagnostics for the manufacturer only.

## Engage / Inspire Console Diagnostic: Lift Motor Information (TR Only)

### User Interface

### Lift Motor Information

Incline Range: <input type="text" value="-3.0% to 15.0%"/>	5.1% to 6.0% Time: <input type="text" value="0:00:00"/>
Lift Time: <input type="text" value="0:02:46"/>	6.1% to 7.0% Time: <input type="text" value="0:00:00"/>
-3.0% to -2.1% Time: <input type="text" value="0:00:02"/>	7.1% to 8.0% Time: <input type="text" value="0:00:00"/>
-2.0% to -1.1% Time: <input type="text" value="0:00:00"/>	8.1% to 9.0% Time: <input type="text" value="0:00:00"/>
-1.0% to -0.1% Time: <input type="text" value="0:00:01"/>	9.1% to 10.0% Time: <input type="text" value="0:00:00"/>
0.0% Time: <input type="text" value="3:20:17"/>	10.1% to 11.0% Time: <input type="text" value="0:00:00"/>
0.1% to 1.0% Time: <input type="text" value="0:15:54"/>	11.1% to 12.0% Time: <input type="text" value="0:00:00"/>
1.1% to 2.0% Time: <input type="text" value="0:03:10"/>	12.1% to 13.0% Time: <input type="text" value="0:00:00"/>
2.1% to 3.0% Time: <input type="text" value="0:02:36"/>	13.1% to 14.0% Time: <input type="text" value="0:00:00"/>
3.1% to 4.0% Time: <input type="text" value="0:01:17"/>	14.1% to 15.0% Time: <input type="text" value="0:00:00"/>
4.1% to 5.0% Time: <input type="text" value="0:08:48"/>	

Back

Export To USB

Main Menu

### Object Table

LABEL	DESCRIPTION
Readouts	<b>Incline Range and Lift Time:</b> Display the incline ranges and lift time from -3.0% to 15.0%. If a product only supports positive incline the range will show up as 0.0% to 15.0%. The maximum allowable incline can be set below 15.0% using the “Max % Incline” configuration setting in the Manager’s Configuration 2 screen. Lift Time shows the total lift time (Lift Motor on time) reported by the motor controller. The lift ranges (i.e. 0.0% Time) shows the amount of time a user worked out in the given incline range.
Export To USB Button	Export all the information on the screen to a USB stick in a .CSV (comma separated value) file.
Back Button	Goes back to the previous screen.
Main Menu Button	Goes back to the System Options – Main Menu.

## Engage / Inspire Console Diagnostic: Belt / Deck Information (TR Only)

### User Interface

**Belt / Deck Information**

**Statistics**

Total Treadmill Hours: 20:43:00      Belt Hours: 20:43:00

Total Treadmill Miles: 9.98      Belt Miles: 9.98

**Event History**

No Events

Back      Export To USB      Main Menu

### Object Table

LABEL	DESCRIPTION
Statistics Readouts	<b>Total Treadmill Hours:</b> Display the total operating hours.
	<b>Total Treadmill Miles:</b> Display the total operating miles.
	<b>Belt Hours:</b> Display the total belt operating hours.
	<b>Belt Miles:</b> Display the total belt operating miles.
Event History	Displays all events history information for belt and deck.
Export To USB Button	Export all the information on the screen to a USB stick in a .CSV (comma separated value) file.
Back Button	Goes back to the previous screen.
Main Menu Button	Goes back to the System Options – Main Menu.

**NOTE:** This test will report any belt wear notifications via the pop up message “Please Check Belt/Deck for Signs of Excessive Wear”. This message is cleared once it has been shown. The Event History will report any events that can led to a notification. The event can be either a slowdown (where user would see the “Unable to Attain Target Speed”) or a distance (mileage) based event (where a notification is issued due to high Belt Miles). When a belt/deck is replaced a “Replacing Belt and Deck” procedure must be submitted in the Maintenance screen for the belt wear notification feature to continue to work properly.

## Engage / Inspire Console Diagnostic: Date and Time Information

### User Interface

**Date and Time Information**

August 2009

S	M	T	W	T	F	S
26	27	28	29	30	31	1
2	3	4	5	6	7	8
9	10	11	12	13	14	15
16	17	18	19	20	21	22
23	24	25	26	27	28	29
30	31	1	2	3	4	5

Today: 8/21/2009

Mode

12 Hour     24 Hour

2 : 00

AM  
 PM

(GMT-08:00) Pacific Time (US & Canada)

Cancel

### Object Table

LABEL	DESCRIPTION
Date and Time Information	<b>Calendar:</b> Shows the current system date and time
	<b>Mode:</b> Indicates the current time format in 12 Hour or 24 Hour mode.
	<b>AM/PM:</b> Indicates the current time in AM/PM.
	<b>Time Zone:</b> Shows the set time zone for the system and allows user to view all available time zone from the drop down.
Cancel Button	Closes the Date and Time Information pop-up and returns to the previous screen.

## Engage / Inspire Console Diagnostic: System Errors

### User Interface

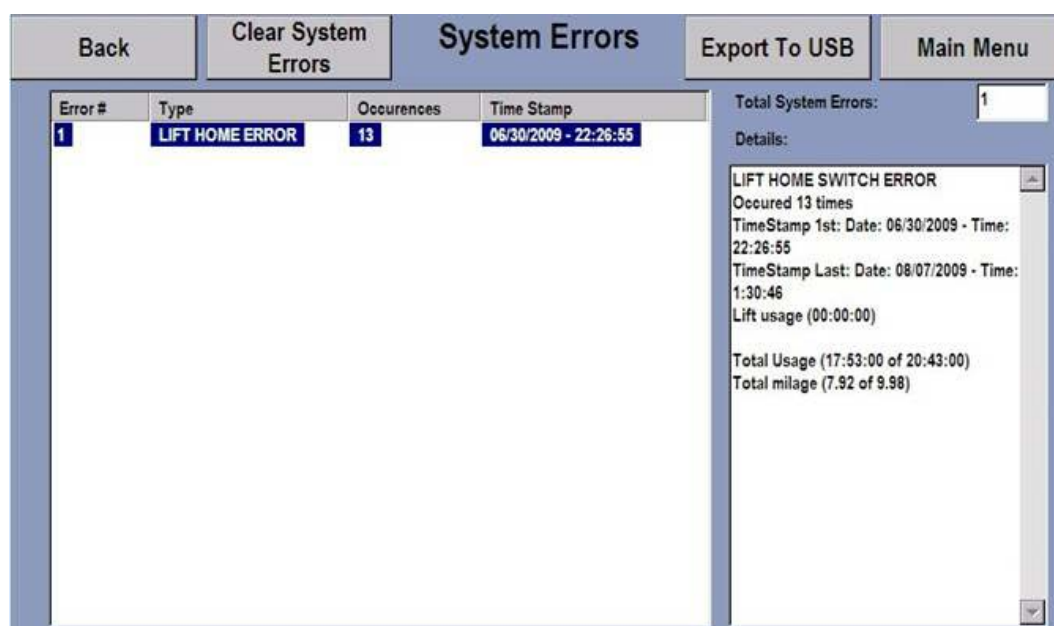

### Object Table

LABEL	DESCRIPTION
Error Readouts	<b>Error #:</b> Displays the number of the error log (last/most recent error log is shown at the top of the list, first error log will be Error #1).
	<b>Type:</b> Displays the type of error (see Details section for an expanded description of the error type).
	<b>Occurrences:</b> Displays the number of occurrences.
	<b>Time Stamp:</b> Displays the date and time of the occurred errors (first and last error if there has been more than one occurrence of the error).
	<b>Total System Errors:</b> Displays the total errors registered by the system.
	<b>Details:</b> Display the error details. Note that many details are for engineering use. Use the scroll bar to the right of this area to scroll down to see additional details, if applicable
Clear System Errors Button	Displays a pass code entry pop-up and allows the user to enter a correct pass code entry. This will allow the system to wipe out all registered system errors.
Export To USB Button	Export all the information on the screen to a USB stick in a .CSV (comma separated value) file.
Back Button	Goes back to the previous screen.
Main Menu Button	Goes back to the System Options – Main Menu.

## Engage / Inspire Console Diagnostic: Maintenance Information

### User Interface

Repair #	Type	Time Stamp	Total System Repairs:
1	REPLACED CONSOLE	01/16/2009 - 17:08:03	3
2	REPLACED CONSOLE	02/19/2009 - 17:35:13	
3	REPLACED CONSOLE	04/16/2009 - 3:42:27	

Details:

REPLACED CONSOLE  
Date: 01/16/2009 - Time: 17:08:03

Total usage (00:48:00 of 20:43:00)  
Total mileage (0.41 of 9.98)

### Object Table

LABEL	DESCRIPTION
Maintenance Information Readouts	<b>Repair #:</b> Displays the number of repairs.
	<b>Type:</b> Displays the type of repairs.
	<b>Time Stamp:</b> Displays the date and time of the occurred repairs.
	<b>Total System Repairs:</b> Displays the total repairs registered by the system.
	<b>Details:</b> Display the repair details.
Clear System Repairs Button	Displays a pass code entry pop-up and allows the user to enter a correct pass code entry which will allow the system to wipe out all registered system repairs.
Export To USB Button	Export all the information on the screen to a USB stick in a .CSV (comma separated value) file
Back Button	Goes back to the previous screen.
Main Menu Button	Goes back to the System Options – Main Menu.

## Engage / Inspire Console Diagnostic: Usage Log Report

### User Interface

Usage Log Report						
MPH	Weight 0 - 99	Weight 100 - 115	Weight 116 - 131	Weight 132 - 147	Weight 148 - 163	Weight
0	9	91	0	0	52	
1	0	12	0	0	23	
2	0	0	0	0	11	
3	0	0	0	0	0	
4	0	0	0	0	0	
5	0	0	0	0	0	
6	0	0	0	0	0	
7	0	0	0	0	0	
8	0	0	0	0	0	
9	0	0	0	0	0	
10	0	0	0	0	0	
11	0	0	0	0	0	
12	0	0	0	0	0	
13	0	0	0	0	0	
14	0	0	0	0	0	

Buttons: Back, Export To USB, Main Menu

### Object Table

LABEL	DESCRIPTION
Usage Log Readouts	<p><b>MPH:</b> Displays and report records of speed usage in mile per hour from 0 – 15 MPH.</p> <p><b>Weight 0 – 400:</b> Displays and report records of weight usage ranges from 0 – 400 pounds.</p>
Export To USB Button	Export all the information on the screen to a USB stick in a .CSV (comma separated value) file.
Back Button	Goes back to the previous screen.
Main Menu Button	Goes back to the System Options – Main Menu.

**NOTE:** This log reports the number of minutes a workout has been used at a given speed range (i.e. 2 mph = workout speeds between 1.1 mph to 2.0 mph, 3 mph = 2.1 to 3.0 mph, etc.) at a given user weight.

## Engage / Inspire Console Diagnostic: Channel Usage Log

### User Interface

Channel Usage Log		
Channel Index ▼	Channel Name	Hours Watched
2	2	0.00
3	3	0.00
4	4	0.00
6	6	0.02
7	7	0.00
8	8	0.00
9	9	0.00
10	10	0.02
11	11	0.00
12	12	0.00
13	13	0.00
14	14	0.00
15	15	0.00
16	16	0.00
17	17	0.00
18	18	0.00

### Object Table

LABEL	DESCRIPTION
Channel Usage Log Readouts	<b>Channel Index:</b> Displays and report records of all available channels.
	<b>Channel Name:</b> Displays and report the name/number of all available channels.
	<b>Hours Watched:</b> Displays and report the number of hours watched per channel for all available channels.
Reset Hours Button	Resets all the hours watched to zero.
Export To USB Button	Export all the information on the screen to a USB stick in a .CSV (comma separated value) file.
Back Button	Goes back to the previous screen.
Main Menu Button	Goes back to the System Options – Main Menu.



## Engage / Inspire Console Diagnostic: Configuration Menu

### User Interface

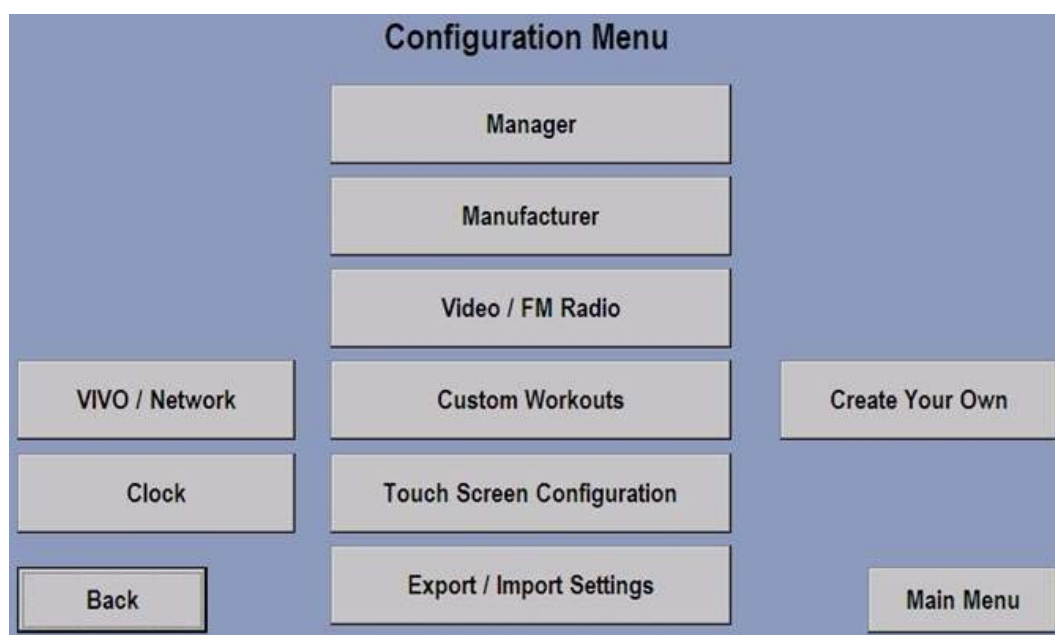

### Object Table

LABEL	DESCRIPTION
Manager Button	Displays the Manager Configuration 1 Screen.
Manufacturer Button	Displays the Pass Code Entry screen. If a valid pass code is entered the system will display the Manufacturer's Configuration screen.
Video / FM Radio Button	Displays the Video / FM Radio Configuration Menu Screen.
Custom Workouts Buttons	Displays the Custom Workouts Setup Screen.
Touch Screen Configuration Button	Executes and displays the Touch Screen Calibration program.
Export / Import Settings Button	Displays the Export / Import Settings Screen.
VIVO / Network Button	Displays the Network Configuration Screen.
Clock Button	Displays the Date and Time Information Screen.
Create Your Own	Displays the Create Your Own Screen.
Back Button	Goes back to the previous screen.
Main Menu Button	Goes back to the System Options – Main Menu.

## Engage / Inspire Console Diagnostic: Manager Configuration 1

### User Interface

### Object Table

LABEL	DESCRIPTION
Language	Allows the manager to select, specify, re-order, enable/disable and set the language flag for the user.
Units	Allows the manager to set the unit of measurement for the system. Note that if the units are changed the Maximum and Minimum Speed settings are reset to defaults.
Maximum Speed (TR only)	Allows the manager to set the maximum speed for the system.
Minimum Speed (TR only)	Allows the manager to set the minimum speed for the system.
Workout Duration Configuration	<p><b>Basic Mode:</b> Allows the manager to set the Max Workout Duration (1 – 99).</p> <p><b>Advanced Mode:</b></p> <ul style="list-style-type: none"> <li>• Peak Time Max Workout Duration: Allows the manager to specify the max workout duration in minutes during peak time.</li> <li>• Off-Peak Time Max Workout Duration: Allows the manager to specify the max workout duration in minutes during off-peak time.</li> <li>• Peak Time 1 &amp; 2: Allow the manager to specify the starting hour/minutes in the AM/PM</li> </ul>
Stand By Configuration	<p><b>Inactivity Timer:</b> Allows the manager to enable/disable and set the Inactivity Timer in hours and minutes.</p> <p><b>Auto Off / Auto On:</b> Allows the manager to specify the AM/PM hour and minutes at which the unit should be automatically turn on/off.</p>
Back Button	Goes back to the previous screen.
Defaults Button	Reset all settings to the manufacturer's defaults.
Forward Button	Displays Manager's Configuration 2 Screen.

## Engage / Inspire Console Diagnostic: Manager Configuration 2

### User Interface

**Manager's Configuration 2**

AZ 3 Speed Keys:  Enabled,  Disabled

Fit Test Plus:  On,  Off

Virtual Trainer:  On,  Off

System Sounds:  On,  Off

Pause Time: 1

Max % Incline: 15.0

Marathon Mode:  Enabled,  Disabled

Telemetry:  Enabled,  Disabled

Accel Rate 3: 3

Custom Message:  Enabled,  Disabled, **Setup**

Stride Sensor:  On,  Off

Program Timeout: 60

Decel Rate 3: 3

Belt Notification Icon:  Enabled,  Disabled

iPod/Nike+:  Enabled,  Disabled

**Back**      **Defaults**      **Main Menu**

### Object Table

LABEL	SPECIFICATION
Activity Zone 3 Speed Keys (TR only)	Allows the manager to enable and disable the Activity Zone speed keys (TR only).
Fit Test Plus	Allows the manager to turn on/off the Fit Test Plus programs. If On the Militray, Gerkin and PEB fit test workouts are shown and available to the user.
Virtual Trainer	Allows the manager to turn on/off the virtual trainer feature.
System Sounds	Allows the manager to turn on/off the system sounds.
Pause Time	Allows the manager to set the pause time of the workout program from 1 – 60 minutes.
Max % Incline	Allows the manager to specify the maximum incline percentage.
Marathon Mode	Allows the manager to enable or disable the Marathon Mode during a workout setup.
Telemetry	Allows the manager to enable or disable the telemetry reading.
Accel Rate 3	Allows the manager to specify the acceleration rate of the belt (TR only). Range = 1 to 5 where 1 = slower acceleration rate and 5 is faster acceleration rate.
Decel Rate 3	Allows the manager to specify the deceleration rate of the belt (TR only). Range = 1 to 5 where 1 = slower deceleration rate and 5 is faster deceleration rate.
Custom Message	Allows the manager to enable or disable the scrolling custom message on the Attract Screen. <b>Setup button:</b> Displays the custom message setup screen and allows the manager to add new or modify existing custom scrolling message.
Stride Sensor	Allows the manager to turn on/off the stride sensor (TR Only).
Program Timeout	Allows the manager to specify the time out of a workout program from 20 – 255 seconds.
Belt Notification Icon	Allows the manager to enable or disable the belt notification icon (TR only).
iPod®/Nike+	Allows the manager to enable or disable the iPod®/Nike+ feature.
Defaults Button	Reset all settings to the manufacturer's defaults.
Back Button	Goes back to the previous screen.
Main Menu Button	Goes back to the System Options – Main Menu.

## Engage / Inspire Console Diagnostic: Manufacturer's Configuration

### User Interface

The screenshot shows the 'Manufacturer's Configuration' screen. It features several input fields and buttons. On the left, there are two numeric keypad controls: 'Drive Ratio' with the value '9659' and 'Smart Stop Adjust' with the value '1'. In the center, there are radio button controls for 'LifePulse' (set to 'Off'), 'Model' (set to '95T'), and 'CC' (set to 'On'). At the bottom center, there are buttons for 'Advanced', 'Exit Application', and 'DEBUG INFO' (set to 'Off'). On the right side, there are three buttons: 'Clear Accum Data', 'Reinit Config Data', and 'Clear System Errors'. At the bottom left is a 'Back' button, and at the bottom right is a 'Main Menu' button.

### Object Table

LABEL	DESCRIPTION
Drive Ratio	Used to change or enter the drive ratio between 7000-9999.
Smart Stop Adjust (TR only)	Used to change or enter the smart stop (Stride Sensor trigger point) adjustment between 0 – 100 (TR only). Default = 0.
LifePulse®	Used to turn on/off the LifePulse® detection.
Model	Used to select the model number for the unit.
CC	Used to turn the CC (Closed Captioning) on/off.
DEBUG INFO	Used to turn on/off debugging information.
Advanced Button	Displays the pass code entry screen and if a correct pass code is entered, the system will display the Advance Manufacturer's Configuration Screen.
Exit Application Button	Shutdown the console application and return to the desktop.
Clear Accum Data Button	Used to clear the accumulated data in the system.
Reinit Config Data Button	Used to reinitialize the system configuration data and reset the console when the operation is completed.
Clear System Errors Button	Used to clear all system errors.
Main Menu Button	Goes back to the System Options – Main Menu.

**NOTE:** These options are mainly for production use and shouldn't be used unless directed to do so.

## Engage / Inspire Console Diagnostic: Manufacturer's Configuration

### User Interface

**Manufacturer's Configuration**

Mem Load Reset Count:

Drive Ratio:  (Keypad: 1 2 3, 4 5 6, 7 8 9, 0)

Smart Stop Adjust:  (Keypad: 1 2 3, 4 5 6, 7 8 9, 0)

Belt Minutes:  (Keypad: 1 2 3, 4 5 6, 7 8 9, 0)

LifePulse:  On,  Off

Model:  95T,  T9

LP PC Comm:  On,  Off

LP:  Record Mode,  Playback Mode

CC:  On,  Off

DEBUG INFO:  (On/Off)

HC12 Reset Count:

Buttons: Clear Accum Data, Reinit Config Data, Clear System Errors, Erase Local EEPROM, Erase External Serial EE, Clear Usage Log, Back, Exit Application, Main Menu

### Object Table

LABEL	DESCRIPTION
Mem Load Reset Count	Displays the memory load reset count.
Drive Ratio	Used to change or enter the drive ratio between 7000-9999.
Smart Stop Adjust (TR only)	Used to change or enter the smart stop adjustment between 0 – 100 (TR only).
Belt Minutes	Used to read, change or enter the belt minutes (TR only).
LifePulse®	Used to turn on/off the LifePulse® detection.
Model	Used to select the model number for the unit.
CC	Used to turn the CC (Closed Captioning) on/off.
DEBUG INFO	Used to turn on/off debugging information.
HC12 Reset Count	Displays the HC12 reset count.
LP PC Communication	Turns the LP (Life Pulse) PC Communication on/off.
LP	Used to select the Life Pulse Record or Playback mode.
Advanced Button	Displays the pass code entry screen and if a correct pass code is entered, the system will display the Advance Manufacturer's Configuration Screen.

## Engage / Inspire Console Diagnostic: Manufacturer's Configuration

### Object Table

LABEL	DESCRIPTION
Exit Application Button	Shutdown the console application and return to the desktop.
Clear Accum Data Button	Used to clear the accumulated data in the system.
Reinit Config Data Button	Used to reinitialize the system configuration data and reset the console when the operation is completed.
Clear System Errors Button	Used to clear all system errors.
Erase Local EEPROM Button	Used to erase the Electrically Erasable Programmable Read-Only Memory (Application settings and logs stored in the console) and automatically reset the console after the operation is completed.
Erase External Serial EE Button	Used to erase the frame Electrically Erasable Programmable Read-Only Memory (Application settings and logs stored in the motor controller) and automatically reset the console after the operation is completed.
Clear Usage Log Button	Used to clear the usage log under Information Menu.
Back Button	Goes back to the previous screen.
Main Menu Button	Goes back to the System Options – Main Menu.

**NOTE:** These options are mainly for production use and shouldn't be used unless directed to do so.

## Engage / Inspire Console Diagnostic: Video / FM Radio Configuration Menu

This will be changed to Media Center Configuration Menu

### User Interface

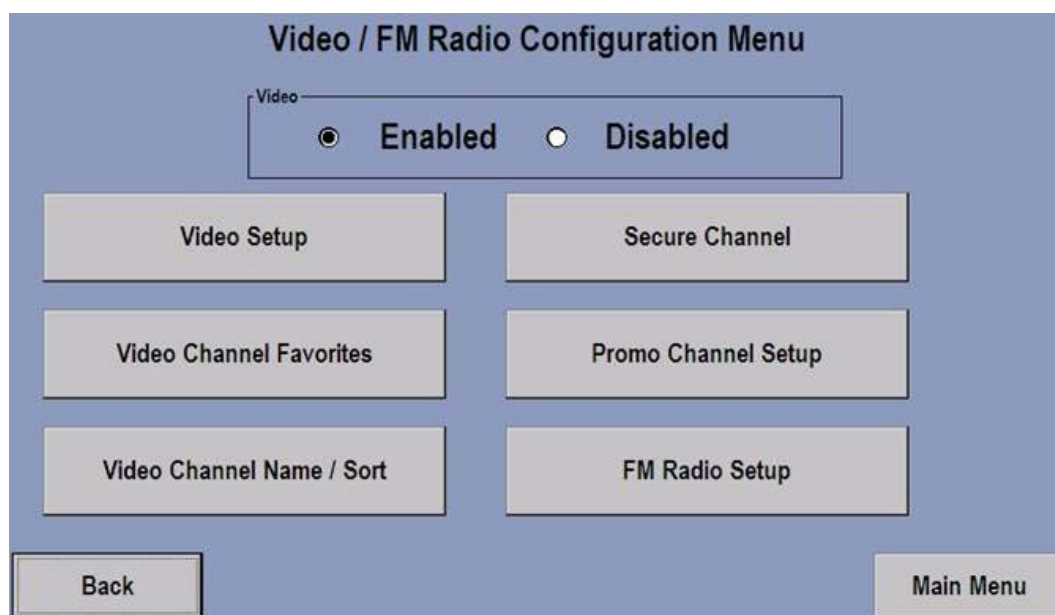

### Object Table

LABEL	DESCRIPTION
Video	Allows the manager to enable or disable the TV Video.
Video Setup Button	Displays the Video Setup Screen if the Video option is enabled.
Video Channel Favorites Button	Displays the Video Channel Favorites Screen if the Video option is enabled.
Video Channel Name / Sort Button	Displays the Video Channel Name / Sort Screen if the Video option is enabled.
Secure Channel Button	Displays the Secure Channel Screen if the Video option is enabled.
Promo Channel Setup Button	Displays the Promo Channel Setup Screen if the Video option is enabled.
FM Radio Setup Button	Displays the FM Radio Setup Screen.
Back Button	Goes back to the previous screen.
Main Menu Button	Goes back to the System Options – Main Menu.
Main Menu Button	Goes back to the System Options – Main Menu.

## Engage / Inspire Console Diagnostic: Video Setup Screen

### User Interface

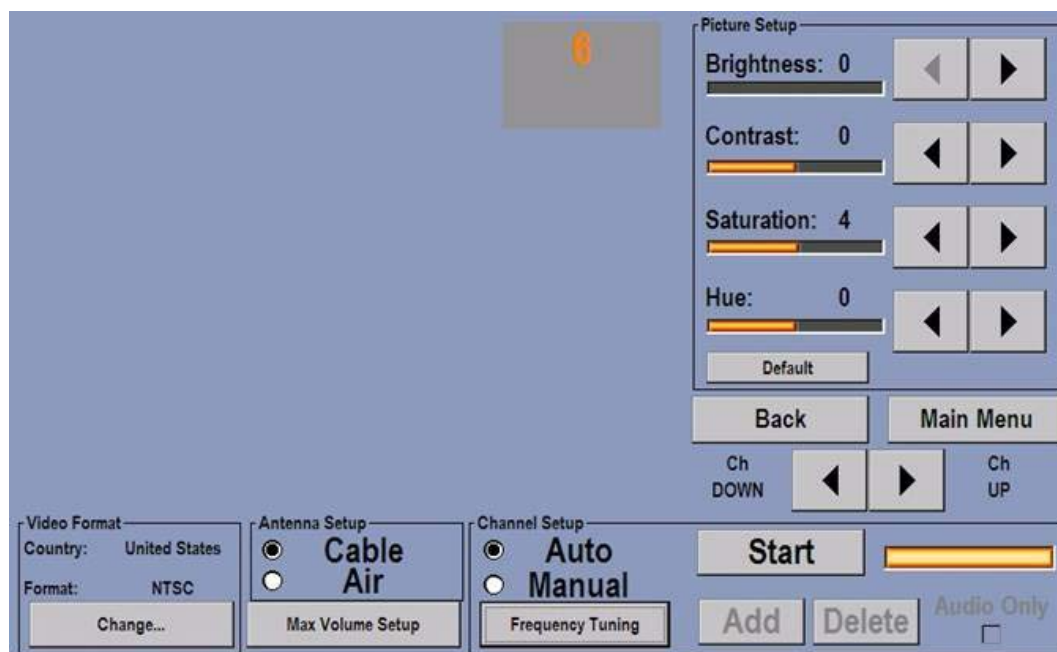

### Object Table

LABEL	DESCRIPTION
Picture Setup	Allows the manager to setup the TV picture by adjusting the Brightness, Contrast, Saturation and Hue using the arrow keys or the Default.
Channel Up/Down	Allows the manager to scroll up/down to available channel(s).
Video Format	Allows the manager to change the video format by selecting the country, format of the tuner (NTSC, PAL, etc.) and sound format.
Antenna Setup	Allows the manager to select either Cable or Air for the antenna source.
Channel Setup	<p>Allows the manager to select either Auto or Manual Frequency Tuning.</p> <p><b>Start Button:</b> Enables if the Auto radio button is selected and allows the manager to select Start to automatically detect the available channel(s).</p> <p><b>Frequency Tuning Button:</b> Displays the Frequency Tuning Screen and allows the manager to scan for available frequency and automatically add channel(s) or manually add/delete channel(s).</p> <p><b>Add Button:</b> Allows the manager to add a channel. This button will enable only if the channel is not already in the list of added channel(s).</p> <p><b>Delete:</b> Allows the manager to delete a channel. This button will enable only if the channel is already added in the list of available channel(s).</p> <p><b>Audio Only:</b> Allows the manager to turn on audio only for the selected channel.</p>
Back Button	Goes back to the previous screen.
Main Menu Button	Goes back to the System Options – Main Menu.



# Engage / Inspire Console Diagnostic: Channel Name / Sort Setup Screen

## User Interface

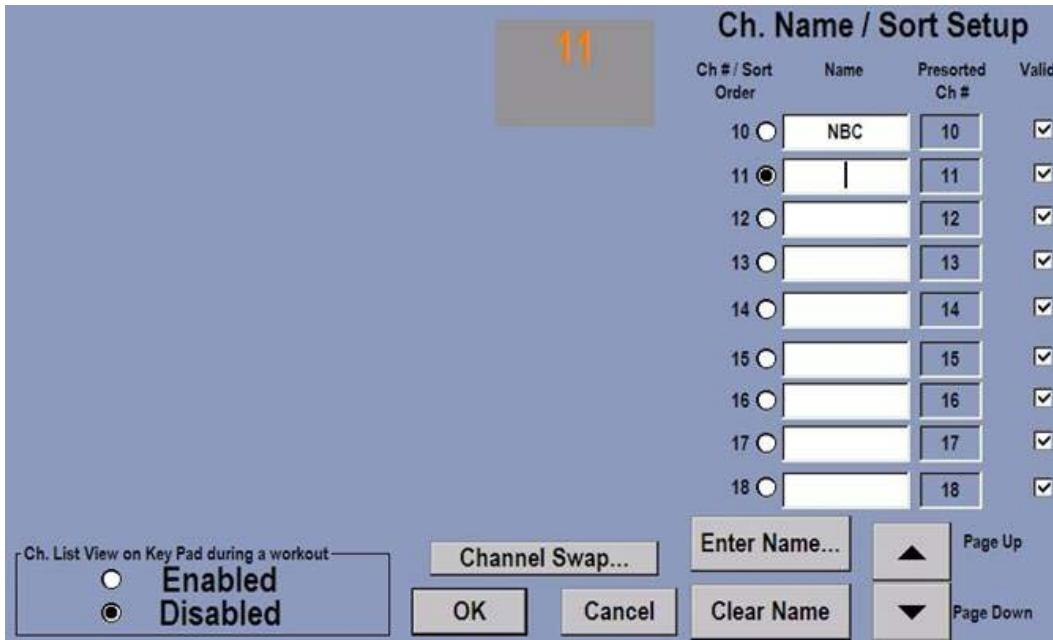

## Object Table

LABEL	DESCRIPTION
Channel Name / Sort Setup	<p><b>Ch # / Sort Order:</b> Displays the channel number in a sort order from low to high and allows the manager to select the radio button and enter the name of the channel.</p> <p><b>Name:</b> Allows the manager to enter the name of the channel.</p> <p><b>Presorted Ch #:</b> Displays the channel # that are presorted by the system</p> <p><b>Valid:</b> Allows the manager to check for valid or uncheck the box for invalid channel. Invalid channel will not be displayed.</p> <p><b>Page Up/Down:</b> Page up and down the list of sorted channel(s).</p>
Enter Name Button	Displays the Enter Channel Name keyboard and allows the manager to enter a channel name.
Clear Name Button	Clear the name of the selected channel.
OK Button	Goes back to the previous screen and saves all changes.
Cancel Button	Goes back to the previous screen and cancels all changes.

## Engage / Inspire Console Diagnostic: Secure Channel Setup Screen

### User Interface

**Secure Channel**

Enabled  Disabled

Channel:

Button Name:

Password:  Enabled  Disabled

### Object Table

LABEL	DESCRIPTION
Secure Channel	Allows the manager to enable/disable the secure channel.
Channel	Allows the manager to specify the secure channel number or change an existing secure channel.
Button Name	Allows the manager to specify the name of button. By default, the name is set to "Secure Channel".
Password	Allows the manager to specify/change a password required to view the secure channel or enable/disable the password protection.
OK Button	Goes back to the previous screen and saves all changes.
Cancel Button	Goes back to the previous screen and cancels all changes.

## Engage / Inspire Console Diagnostic: Promo Channel Setup Screen

### User Interface

**Promo Channel Setup**

Enabled     Disabled

Promo Channel

1    Change...

Advanced Promo Channel settings

Start with Promo Channel

Return to Promo Channel (Minutes):

No Limit

OK    Cancel

### Object Table

LABEL	DESCRIPTION
Promo Channel Setup	Allows the manager to enable/disable the promo channel setup feature.
Promo Channel	Allows the manager to change/specify the promo channel number.
Advanced Promo Channel Settings	Allows the manager to select Promo Channel as the starting channel or specify the time limit for returning to the promo channel in minutes.
OK Button	Goes back to the previous screen and saves all changes.
Cancel Button	Goes back to the previous screen and cancels all changes.

## Engage / Inspire Console Diagnostic: FM Radio Setup Screen

### User Interface

The screenshot shows the FM Radio Setup interface. At the top, the title "FM Radio Setup" is centered. Below it are two radio buttons: "Enabled" (selected) and "Disabled". A sub-section titled "Presets Setup" contains two radio buttons: "Enabled" (selected) and "Disabled". Below these are two radio buttons: "Auto" (selected) and "Manual". To the right of "Auto" is a "Start" button and a horizontal bar. Below "Manual" are "Add" and "Delete" buttons. Below the "Presets Setup" section is an "MHz" label above a text field containing "87.5". To the left of the text field is a "Ch DOWN" label with a left arrow button, and to the right is a "Ch UP" label with a right arrow button. At the bottom left is a "Back" button, and at the bottom right is a "Main Menu" button.

### Object Table

LABEL	DESCRIPTION
FM Radio Setup	Allows the manager to enable/disable the FM radio.
Preset Setup	Allows the manager to enable/disable the preset or to set the preset to Auto or Manual setup. <ul style="list-style-type: none"> <li>• <b>Start:</b> Pulls the preset channel automatically if the Auto option is checked.</li> <li>• <b>Manual:</b> Allows the manager to manually select the add/delete button, to add or delete a preset.</li> <li>• <b>Ch UP/DOWN arrow keys:</b> Scans the available FM radio frequencies.</li> </ul>
Back Button	Goes back to the previous screen and saves all changes.
Main Menu	Goes back to the System Options – Main Menu.

## Engage / Inspire Console Diagnostic: Custom Workouts Screen

### User Interface



### Object Table

LABEL	DESCRIPTION
Password	Allows the manager to enable/disable the password protection for gaining access to the custom workout programs. <ul style="list-style-type: none"> <li>• <b>View button:</b> Views the current password.</li> <li>• <b>Change button:</b> Allows the manager to change the current password.</li> </ul>
Enter Name Button	Displays the Enter Channel Name keyboard and allows the manager to enter a channel name.
Back Button	Goes back to the previous screen and saves all changes.
Main Menu	Goes back to the System Options – Main Menu.

## Engage / Inspire Console Diagnostic: Export / Import Settings

### User Interface



### Object Table

LABEL	DESCRIPTION
Settings	<p>Allows the manager to select All Settings or TV and Radio Settings Only to be exported to or imported from a USB stick.</p> <ul style="list-style-type: none"> <li>• <b>Export Setting To USB Stick Button:</b> Exports all settings or TV and Radio Settings Only to the inserted USB stick.</li> <li>• <b>Import Settings From USB Stick:</b> Imports all Settings or TV and Radio Settings Only from the inserted USB stick and restores those settings to the system. Once the import operation is completed the system will automatically be rebooted.</li> </ul>
Back Button	Goes back to the previous screen and saves all changes.
Main Menu	Goes back to the System Options – Main Menu.

## Engage / Inspire Console Diagnostic: Create Your Own Screen

### User Interface

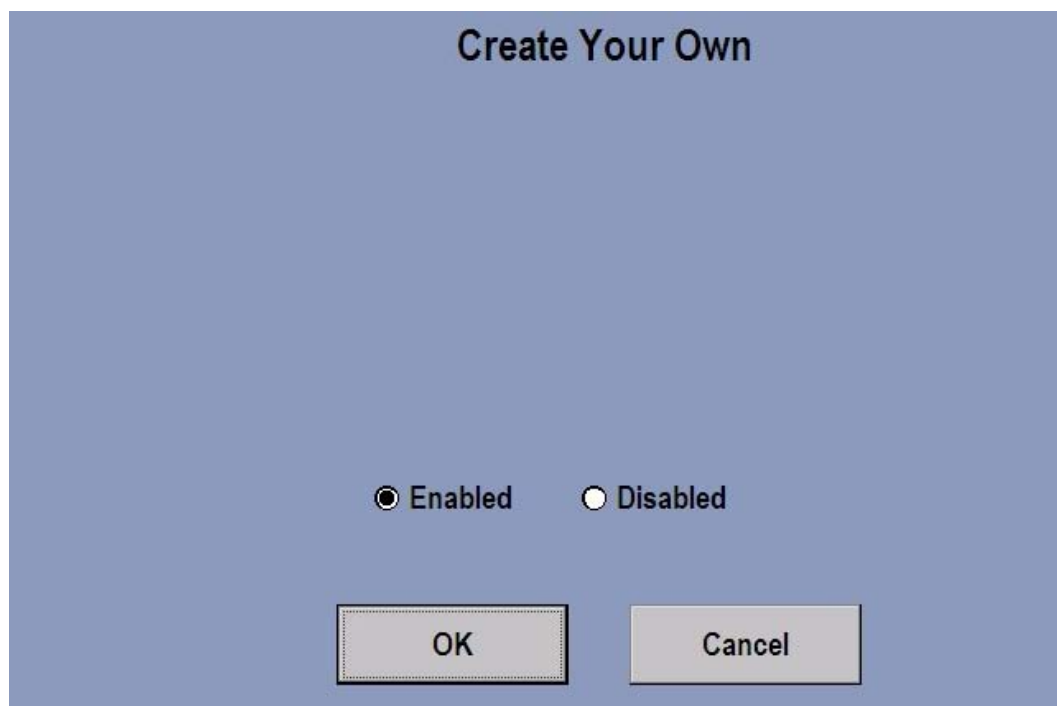

### Object Table

LABEL	DESCRIPTION
Create Your Own	Allows the manager to enable/disable the Create Your Own workout programs.
Back Button	Goes back to the previous screen and saves all changes.
Main Menu	Goes back to the System Options – Main Menu.





# Engage / Inspire Console Diagnostic: Clock Setup (Date and Time Information)

## User Interface

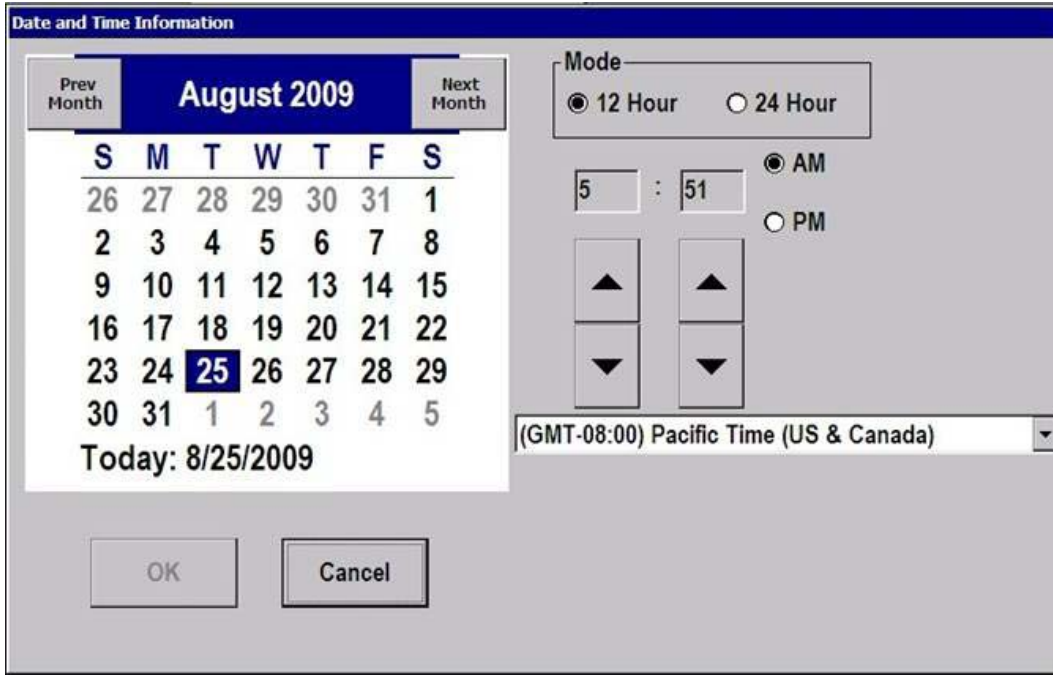

## Object Table

LABEL	DESCRIPTION
Date and Time Information	<b>Calendar:</b> Shows and allows the manager to change the current system date and time
	<b>Mode:</b> Indicates and allows the manger to change the current time format in 12 Hour or 24 Hour mode.
	<b>AM/PM:</b> Indicates and allows the manager to change the current time in AM/PM.
	<b>Time Zone:</b> Shows the set time zone for the system and allows the manager to view or change the timezone.
OK Button	Accept all the changes and returns to the previous screen.
Cancel Button	Closes the Date and Time Information pop-up and returns to the previous screen.

## Engage / Inspire Console Diagnostic: Maintenance

### User Interface

**Maintenance**

Replacing Belt and Deck
  Replacing Stop Switch  
 Replacing Console
  Replacing Overlay Bezel  
 Replacing Motor Controller
  Replacing Main Motor  
 Replacing Lift Motor

### Object Table

LABEL	DESCRIPTION
Replacing Belt and Deck	Allows the technician to indicate the replacement of belt and deck (TR only).
Replacing Console	Allows the technician to indicate the replacement of the unit's console.
Replacing Motor Controller	Allows the technician to indicate the replacement of the unit's motor controller (TR only).
Replacing GBC	Allows the technician to indicate the replacement of the unit's generator break controller (Non TR only).
Replacing Stop Switch	Allows the technician to indicate the replacement of the unit's emergency stop switch.
Replacing Overlay Bezel	Allows the technician to indicate the replacement of the unit's overlay bezel.
Replacing Main Motor	Allows the technician to indicate the replacement of the unit's main motor (TR Only)
Replacing Lift Motor	Allows the technician to indicate the replacement of the unit's Lift Motor (TR only)
Telemetry	Allows the manager to enable or disable the telemetry reading.
Submit Button	Submit and save the maintenance activity to the maintenance log.
Back Button	Goes back to the previous screen.
Main Menu Button	Goes back to the System Options – Main Menu.

**NOTE:** For proper operation of some features technicians must submit repairs on this screen (i.e. Must submit a "Replacing Belt and Deck" to get the belt wear notification feature (see Belt/Deck Info) to work properly as well as the belt hours and mileage readouts).

## Error / Info Messages

### Overview

The following table lists the error or informational messages a user or service can see including a description of what they mean. Applies to the current Elevation based treadmill products (Engage, Inspire). This information is intended to be used in the service manuals with input from the software and hardware group. It is based on the current **SBC** (v1.10), **MIB** (w/ Rev E support) and DSP motor controller software releases.

MESSAGE	DESCRIPTION	POSSIBLE CAUSE	SECTION	PAGE
"Error launching application. Please reload using USB memory stick."	<b>SBC</b> application was unable to launch.	Application missing	Reload application using USB setup utility.	
"Interface board in Boot mode - please start Flash update now"	<b>MIB</b> application checksum error detected.	Software update was interrupted via a power failure or bad connection with the USB stick, PC update application or widget box.	Re-flash/update the <b>MIB</b> software.	
"Motor controller in Boot mode - please start Flash update now"	Motor controller checksum error detected.	Software update was interrupted via a power failure or bad connection with the USB stick, PC update application or widget box.	Re-flash/update the motor controller software.	
"Stuck hard key detected"	Indicates at least one hard key on any of the keypads is being detected as closed when the <b>MIB</b> initially powers up. Intent is to detect a faulty keypad and prevent any subsequent key events from being sent to the <b>SBC</b> .	One or more keys are either shorted closed or are being held down at power up.	Replace keypad(s) or if user is purposely holding down a key at power up then cycle power to recover.	
"Interface board not detected"	Communications between the <b>SBC</b> and <b>MIB</b> board were not able to be established .	Faulty connection between <b>SBC</b> and <b>MIB</b> boards.	Check board to board connection.	
"Module communication error" <sup>2</sup>	<b>MIB</b> (or Achieve console) is unable to communicate with the motor controller module (i.e. module no communication).	Power up communication test to base failed or lost communication with base.	Check/replace cabling down to the M/C.	

## Error / Info Messages

MESSAGE	DESCRIPTION	POSSIBLE CAUSE	SECTION	PAGE
"Module communication error. RetroFit DSP MC detected"	<b>SBC</b> has detected that a "RetroFit" DSP motor controller has been installed. RetroFit controllers are not to be used on Elevation products.	<b>SBC</b> has detected that an invalid DSP motor controller has been installed.	Replace the M/C with one with the correct assembly number.	
"Edit base assembly serial #"	This is a prompt to enter in the base serial number and then the product type.	The prompt will occur if there is no valid configuration data in both the <b>SBC</b> registry and the motor controller. This will also occur if both the console and motor controller are replaced at the same time.	Enter the base serial number located on the label attached to the frame and set the correct product type when prompted.	
"Maintenance" at the top of the screen	This is a data entry prompt that will ask the tech. to select either "Replacing Console" or "Replacing Motor Controller".	This prompt occurs if the basic configuration data stored in both the registry and motor controller doesn't match. This will occur if the console or motor controller is replaced with assemblies that already have configuration data stored in them (These assemblies are typically sent out with blank basic configuration data in which case you wouldn't see this prompt).	If you replaced the console, then select "Replacing Console". Otherwise select "Replacing Motor Controller".	
"Please pedal" <sup>2</sup>	Initialization does not finish (stuck in this mode) due to lack of communication between <b>MIB</b> & motor controller.	<b>Most likely:</b> JW3 installed on DSP M/C. <b>Less likely:</b> Broken Rx/Tx lines in cable, <b>MIB</b> or M/C.	Remove JW3. Check/replace cabling down to the M/C.	

## Error / Info Messages

MESSAGE	DESCRIPTION	POSSIBLE CAUSE	SECTION	PAGE
“Notify maintenance communication timeout (motor controller)” <sup>2</sup>	Lost communications with the motor controller (i.e. module communication timeout).	Broken communication lines, JW3 installed on DSP M/C.	Remove JW3. Check/replace cabling down to the M/C. Vibration is causing intermittent operation from loose connection.	
“Notify maintenance motor controller error (thermal shutdown)”	Motor controller shut down due to excessive temperature.	M/C compartment airflow restricted, hot air is being blown on it, located in direct sunlight. Excessively worn belt/deck.	Clean the M/C compartment, insure adequate ventilation is available and it is not being heated by a heating register, move from direct sunlight. Replace belt/deck if power level is excessive.	
“Notify maintenance motor temperature trip”	Motor shut down due to excessive temperature.	Faulty/intermittent thermal switch in motor. M/C compartment airflow restricted, hot air is being blown on it, located in direct sunlight. Excessively worn belt/deck.	Check motor thermal switch connections. Check clean the M/C compartment, insure adequate ventilation is available and it is not being heated by a heating register, move from direct sunlight. Replace belt/deck if power level is excessive. Replace motor if error keeps occurring after the motor has cooled down and no other solution has worked.	
“Warning - step off belt, maximum voltage trip”	Excessive belt motor bus voltage detected.	User is driving the belt with sufficient energy to raise the bus voltage, most likely at high inclines. Input line has voltage surge problems.	Instruct the user to not drive the belt at high inclines or use a lower incline. Contact an electrician to diagnose/correct a power line problem.	
“Notify maintenance motor controller error (hardware current trip)”	Excessive motor current detected.	Excessive motor current caused by a failed motor, intermittent motor or motor connection(s). A possible but unlikely cause would be a severely worn belt/deck.	Verify that all motor connections and cables are solid. If start-up power is very weak a phase may be faulty. Perform a phase test to verify the system or diagnose a problem.	

## Error / Info Messages

MESSAGE	DESCRIPTION	POSSIBLE CAUSE	SECTION	PAGE
"Notify maintenance motor controller error (low voltage detected)"	Non-fatal error. Line voltage dropped to an insufficient level to sustain proper operation.	Line cord is not securely plugged into the wall or machine. Loose/intermittent receptacle wiring. Machine is not plugged into a proper dedicated line. Incoming voltage is fluctuating, dipping to an insufficient level.	Confirm that the cord is solidly plugged into the wall receptacle and the machine. Contact an electrician to diagnose/correct a power line problem.	
"Start up error"	Non-fatal error. No/low motor current is detected at start-up.	Motor unplugged or connector loose. A possible but unlikely cause would be the user driving the belt at startup.	Verify that the motor connections are solid. Perform a phase test to verify the system or diagnose a phase problem.	
"Motor disabled"	Non-fatal error. The M/C has detected an open stop switch when operating that the console has not detected.	An intermittent console/motor controller cable or emergency stop switch.	Confirm that all connections are solid, all wires are properly seated into the connector and the cable is not pinched and being shorted/open. Verify proper operation of the emergency stop switch.	
"Incline inoperative - continue if desired"	Indicates the incline system has a problem but system can still be used. Occurs if DSP reports a lift Home Switch error or timeout error.	Improper home or decline switch operation / adjustment / cable. Incline motor connection unplugged / loose. A possible but unlikely cause would be incline motor overheating from excessive operation.	Verify that all motor and switch connections and cables are solid. Verify incline switch operation using diagnostic switch LEDS (LED 9&10). Verify incline motor activation using diagnostic LEDS (LED 4&5). Readjust or replace switches/cables.	

## Error / Info Messages

MESSAGE	DESCRIPTION	POSSIBLE CAUSE	SECTION	PAGE
"Unexpected interface board reset"	Indicates the <b>MIB</b> board has gone through an unexpected reset.	<b>MIB</b> board lost and then regained power or was reset. This can be caused by electrostatic discharge.	Verify connection from console's rear plastic to 92353 Polar Board is tight. Verify that the lower right screw (viewed from rear) that holds the console to the base is tight, has a star washer, and is 8mm long.	
"Activity Zone keypad not detected"	The absence of a <b>loopback</b> signal indicates the Activity Zone keypad is not properly connected.	If it used to work, and now doesn't, it is likely due to an intermittent or unplugged Activity Zone connector. If it has not worked since the console or <b>MIB</b> was replaced (which automatically enables the Activity Zone detect feature), the console - Activity Zone cable may be out of date.	Confirm that all connections are solid, all wires are properly seated into the connector and the cable is not pinched. If the console (or <b>MIB</b> ) has been replaced with a newer, larger <b>MIB</b> ("A080-92334-0001" on Polar Board silk screen), verify that the Console Activity Zone cable is AK65-00043-0001, Rev A2 or later. Replace cable if it is AK65-00043-0000 or AK65-00043-0001, Rev A1.	
"Emergency stop drive trip"	<b>MIB</b> EStop drive circuitry detects a shorted condition.	Tether / magnet loose or not installed; Poly-resettable fuse (PTC2) or Q5 on <b>MIB</b> are open; Over current condition on emergency stop relay on motor controller.	Verify tether / magnet are properly replaced / installed. Replace <b>MIB</b> . Replace Motor Controller.	
"Console over temperature"	<b>MIB</b> has detected an internal console temperature of over 50 degrees celsius.	Console vents may have been blocked by a towel, etc.	This is an informational message and is intended for engineering only.	
"Network voltage driver trip"	<b>MIB</b> voltage drive circuitry to CSAFE port detected a shorted condition.	Faulty accessory plugged into the CSAFE port.	Remove CSAFE accessory.	

## Error / Info Messages

MESSAGE	DESCRIPTION	POSSIBLE CAUSE	SECTION	PAGE
"Stop key activated"	MIB has decoded a Stop key press. System aborts workout.	Faulty Activity Zone keypad.	Check proper operation of keypad in diagnostics and replace if necessary.	
"Unable to attain target speed" <sup>1</sup>	Reported if the motor controller was unable to attain the desired user's speed after a given amount of time.	Line voltage low, unit overloaded; too much weight for speed requested. Worn belt and/or deck.	Check belt & deck for signs of excessive wear and replace if necessary.	
"Miscellaneous interface communication error"	Typically this is reported if SBC was unable to properly activate the belt and/or incline motors.	Communications error with the motor controller.	See "Module communication error"	
"Workout initialization time-out. Resetting system....."	System was unable to enable the belt and/or incline motors while starting a workout	Communications error with the motor controller.	See "Module communication error"	
"Please replace emergency stop switch"	Emergency stop (tether) is replaced, but console still gives this message.	Tether / magnet loose or not installed; Poly-resettable fuse (PTC2) or Q5 on MIB are open; Over-current condition on emergency stop relay on motor controller.	Verify tether / magnet are properly replaced / installed. Replace MIB. Replace motor controller.	

<sup>1</sup> When user sees this message the belt speed will decrease automatically. If user is already at minimum speed (i.e. 0.5 mph) then workout will enter Pause mode. If speed is more than one mph/kph below target speed then speed is reduced by ½. If speed is closer to target when an "Unattained..." occurs then speed is decremented between 0.1 to 0.3 mph/kph.

<sup>2</sup> A simple test to determine if console is communicating with the motor controller is to cycle power and listen for beeps from the MIB board. The MIB will beep once after it gets power followed by three additional beeps if it can successfully communicate with the motor controller. This process is done before the main Application on the SBC is up and running (i.e. before you see the "Splash" screen which contains the word "initializing" on it).